

Ice-O-Matic[®]

SERVICE PARTS MANUAL
MODEL-ICE1806 and ICE1807 Version 3
MODEL-ICE2106 and ICE2107 Version 3



Ice-O-Matic
11100 East 45th Ave
Denver, Colorado 80239
14-1027

Date 10/5/15

ICE1800 and 2100 Series Version 3 Service Parts

This parts list contains the service parts available for the following icemakers.

ICE1806 Water and Remote Version 3

ICE1807 Water and Remote Version 3

ICE2106 Water and Remote Version 3

ICE2106 Water and Remote Version 3

Check the model number on the data plate and refer to the correct listing for the specific component.

Check carefully that the correct part is identified and ordered.

Table of Contents	Page 1
Exterior Panels	Page 2
Water Cooled	Page 4
Remote	Page 6
Control Box	Page 8
Harvest Assist	Page 10
Water Pump/Float	Page 12
VRC Condenser	Page 14

Ice-O-Matic
11100 East 45th Ave.
Denver Co. 80239
800-423-3367

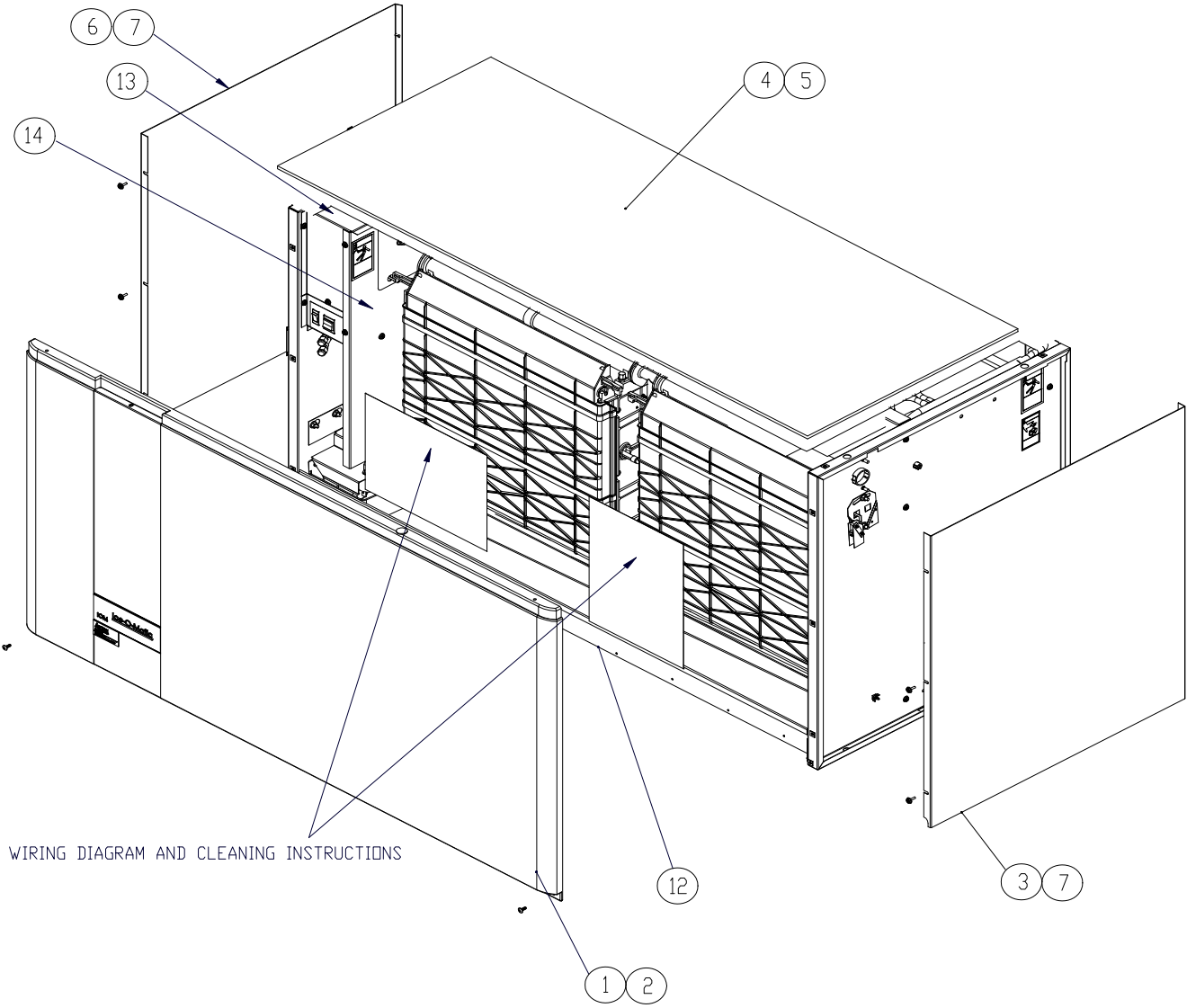
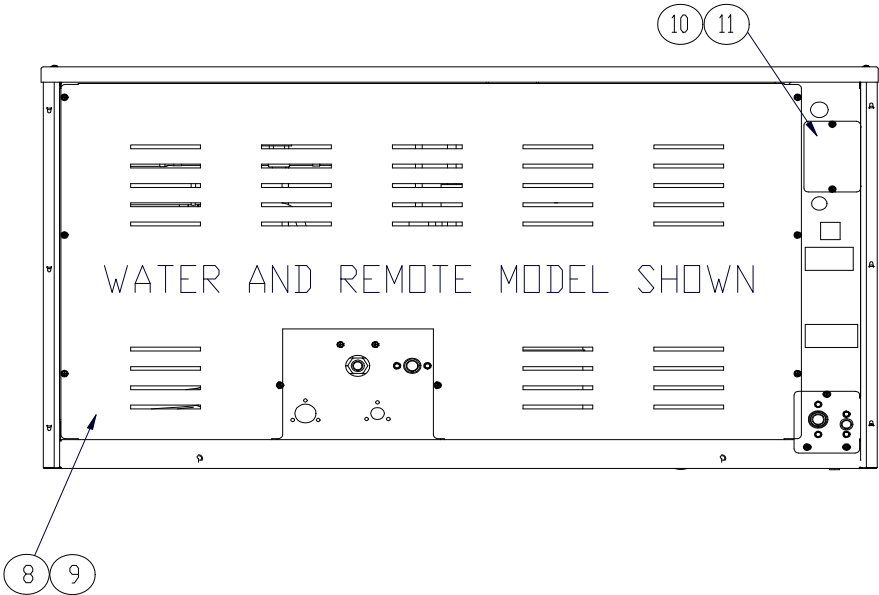

Item No.	Model Number				Description
	ICE1806V3	ICE1807V3	ICE2106V3	ICE2107V3	
1	2031465-05S	2031465-05S	2031465-05S	2031465-05S	Front Panel
2	9031098-02	9031098-02	9031098-02	9031098-02	Front Panel Screws
3	3021929-01	3021929-01	3021929-01	3021929-01	Right Hand Side Panel-Water Cooled and Remote Only
4	9051469-01	9051469-01	9051469-01	9051469-01	Top Panel NLA
5	9031098-02	9031098-02	9031098-02	9031098-02	Top Panel Screws
6	3021934-01	3021934-01	3021934-01	3021934-01	Left Hand Side Panel-Water Cooled and Remote Only
7	9031046-03	9031046-03	9031046-03	9031046-03	Side Panel Screw
8	3021926-01	3021926-01	3021926-01	3021926-01	Rear Panel
9	9031046-01	9031046-01	9031046-01	9031046-01	Rear Cover Panel Screws
10	3013308-01	3013308-01	3013308-01	3013308-01	Junction Box Cover
11	9031046-01	9031046-01	9031046-01	9031046-01	Junction Box Cover Screws
12	3013315-01	3013315-01	3013315-01	3013315-01	Ice Deflector
13	3013294-01	3013294-01	3013294-01	3013294-01	Control Box Top Cover
14	3013293-01	3013293-01	3013293-01	3013293-01	Control Box Side Cover
15	N/A	N/A	N/A	N/A	Machine Compartment Cover

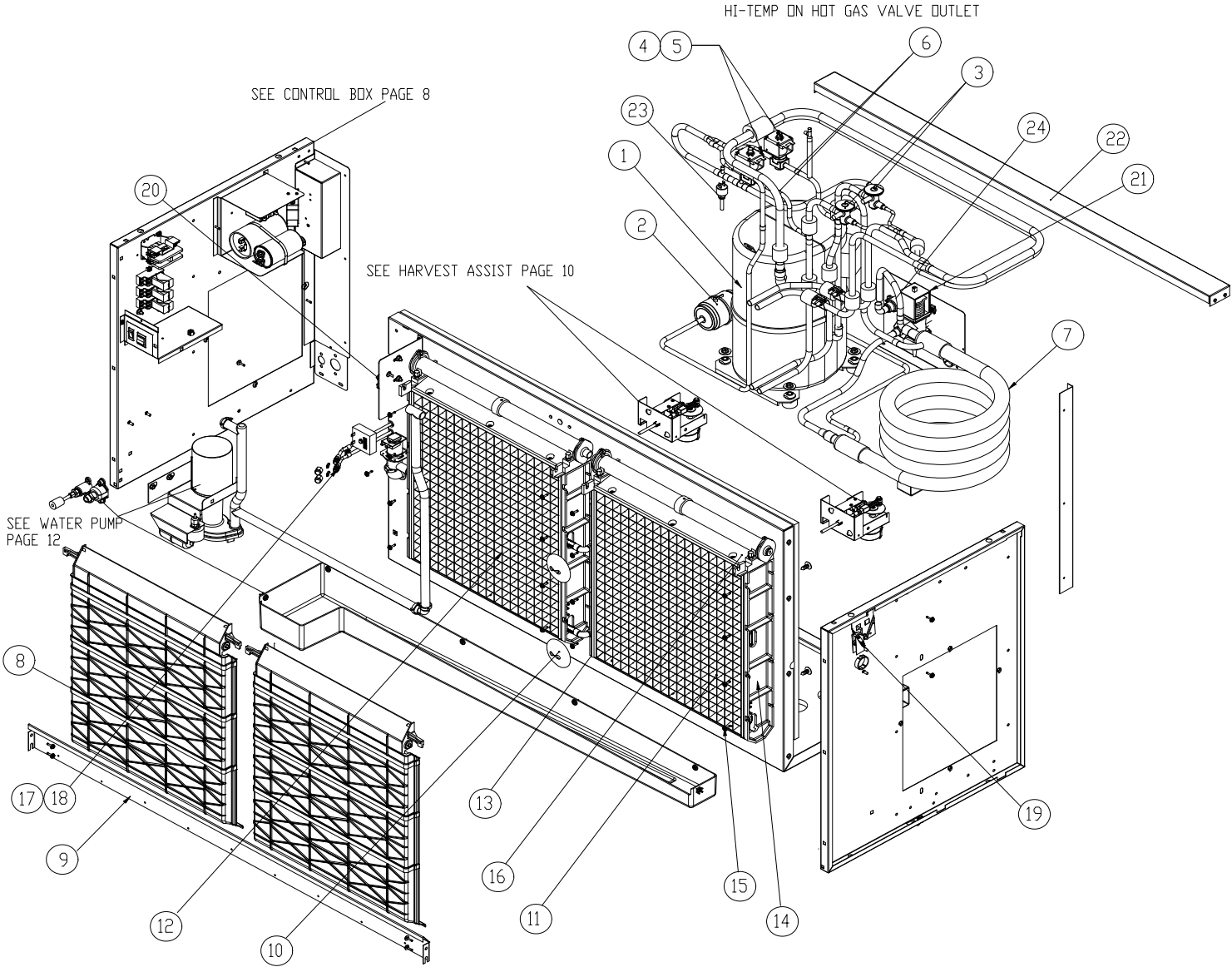

Item No.	Model Number				Description
	ICE1806V3	ICE1807V3	ICE2106V3	ICE2107V3	
1	9181108-11	9181108-12	9181129-11	9181129-12	Compressor NLA See Below
2	9151163-02	9151163-02	9151163-02	9151163-02	Filter Drier (9151004-03 is NLA)
3	9151152-101	9151152-101	9151152-101	9151152-101	Expansion Valve (Includes Valve, Insulation and Strap)
4	9151123-02	9151123-02	9151123-02	9151123-02	Hot Gas Valve Body
5	9151123-04	9151123-04	9151123-04	9151123-04	Hot Gas Valve Coil
6	9041098-01	9041098-01	9041098-01	9041098-01	High Temperature Safety Control
7	9141123-01	9141123-01	9141123-01	9141123-01	Water Condenser
8	9051154-12	9051154-12	9051154-12	9051154-12	Evaporator Splash Curtain
9	3013315-01	3013315-01	3013315-01	3013315-01	Ice Deflector
10	9051237-02	9051237-02	9051237-02	9051237-02	Washer Tube
11	2051250-81	2051250-81	2051250-81	2051250-81	Evaporator Right Side Full Cube (Replaces 2051239-81)
11	2051250-82	2051250-82	2051250-82	2051250-82	Evaporator Right Side Half Cube (Replaces 2051239-82)
12	2051251-81	2051251-81	2051251-81	2051251-81	Evapoartor Left Side Full Cube (Replaces 2051240-81)
12	2051251-82	2051251-82	2051251-82	2051251-82	Evapoartor Left Side Half Cube (Replaces 2051240-82)
13	9051170-04	9051170-04	9051170-04	9051170-04	Evaporator Left Side Mounting Panel
14	9051170-03	9051170-03	9051170-03	9051170-03	Evaporator Right Side Mounting Panel
15	9051135-04	9051135-04	9051135-04	9051135-04	Water return
16	9051135-05	9051135-05	9051135-05	9051135-05	Spillway
17	9091086-02	9091086-02	9091086-02	9091086-02	Valve Core
18	9091086-03	9091086-03	9091086-03	9091086-03	Valve Cap
19	9101124-02	9101124-02	9101124-02	9101124-02	Bin Switch Right Side (Cut Arm)
20	9101124-02	9101124-02	9101124-02	9101124-02	Bin Switch Left Side (Cut Arm)
21	9041056-01	9041056-01	9041056-01	9041056-01	Water Regulating Valve
22	3013316-01	3013316-01	3013316-01	3013316-01	Rear Brace
23	9041091-01	9041091-01	9041091-01	9041091-01	High Pressure Control
24	9091063-02	9091063-02	9091063-02	9091063-02	Condenser Drain Fitting



9181108-12 = NLA, Replaced by 9181143-13

9181129-11 = NLA, Replaced by 9181144-11

9181129-12 = NLA, Replaced by 9181144-12

9181108-11 = NLA, Replace by 9181143-11

See Page 9 for Specific Compressor Components

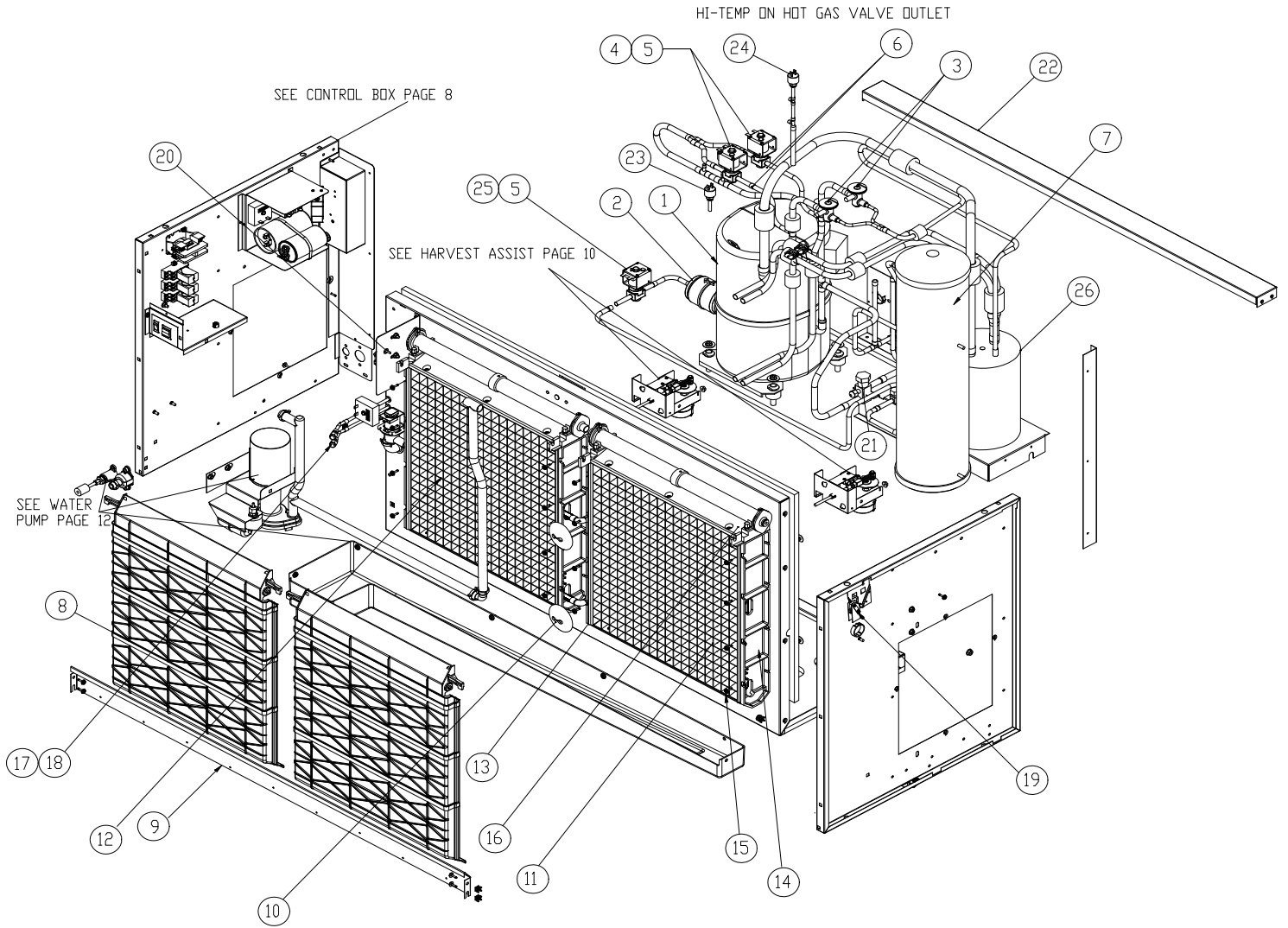

Item No.	Model Number				Description
	ICE1806V3	ICE1807V3	ICE2106V3	ICE2107V3	
1	9181108-11	9181108-12	9181129-11	9181129-12	Compressor NLA See Below
2	9151163-02	9151163-02	9151163-02	9151163-02	Filter Drier (9151004-03 is NLA)
3	9151152-101	9151152-101	9151152-101	9151152-101	Expansion Valve (Includes Valve, Insulation and Strap)
4	9151123-02	9151123-02	9151123-02	9151123-02	Hot Gas Valve Body
5	9151123-04	9151123-04	9151123-04	9151123-04	Hot Gas Valve Coil
6	9041098-01	9041098-01	9041098-01	9041098-01	High Temperature Safety Control
7	9151109-01	9151109-01	9151109-01	9151109-01	Receiver
8	9051154-12	9051154-12	9051154-12	9051154-12	Evaporator Splash Curtain
9	3013315-01	3013315-01	3013315-01	3013315-01	Ice Deflector
10	9051237-02	9051237-02	9051237-02	9051237-02	Washer Tube
11	2051250-81	2051250-81	2051250-81	2051250-81	Evaporator Right Side Full Cube (Replaces 2051239-81)
11	2051250-82	2051250-82	2051250-82	2051250-82	Evaporator Right Side Half Cube (Replaces 2051239-82)
12	2051251-81	2051251-81	2051251-81	2051251-81	Evapoartor Left Side Full Cube (Replaces 2051240-81)
12	2051251-82	2051251-82	2051251-82	2051251-82	Evapoartor Left Side Half Cube (Replaces 2051240-82)
13	9051170-04	9051170-04	9051170-04	9051170-04	Evaporator Left Side Mounting Panel
14	9051170-03	9051170-03	9051170-03	9051170-03	Evaporator Right Side Mounting Panel
15	9051135-04	9051135-04	9051135-04	9051135-04	Water Return
16	9051135-05	9051135-05	9051135-05	9051135-05	Spillway
17	9091086-02	9091086-02	9091086-02	9091086-02	Valve Core
18	9091086-03	9091086-03	9091086-03	9091086-03	Valve Cap
19	9101124-02	9101124-02	9101124-02	9101124-02	Bin Switch Right Side (Cut Arm)
20	9101124-02	9101124-02	9101124-02	9101124-02	Bin Switch Left Side (Cut Arm)
21	9091143-02	9091143-02	9091143-02	9091143-02	Remote Shut-Off Valve (Large)
	9091143-01	9091143-01	9091143-01	9091143-01	Remote Shut-Off Valve (Small)
22	3013316-01	3013316-01	3013316-01	3013316-01	Rear Brace
23	9041091-01	9041091-01	9041091-01	9041091-01	High Pressure Control
24	9041092-02	9041092-02	9041092-02	9041092-02	Pump Down Control
25	9151123-02	9151123-02	9151123-02	9151123-02	Liquid Line Solenoid
26	2101421-01	2101421-01	2101421-01	2101421-01	Accumulator Assembly
	9091001-12	9091001-12	9091001-12	9091001-12	1/2 Inch Coupling (Not Shown)
	9091001-11	9091001-11	9091001-11	9091001-11	3/8 Inch Coupling (Not Shown)
	9151139-01	9151139-01	9151139-01	9151139-01	Check Valve (Not Shown)



9181108-12 = NLA, Replaced by 9181143-13

9181129-11 = NLA, Replaced by 9181144-11

9181129-12 = NLA, Replaced by 9181144-12

9181108-11 = NLA, Replace by 9181143-11

See Page 9 for Specific Compressor Components

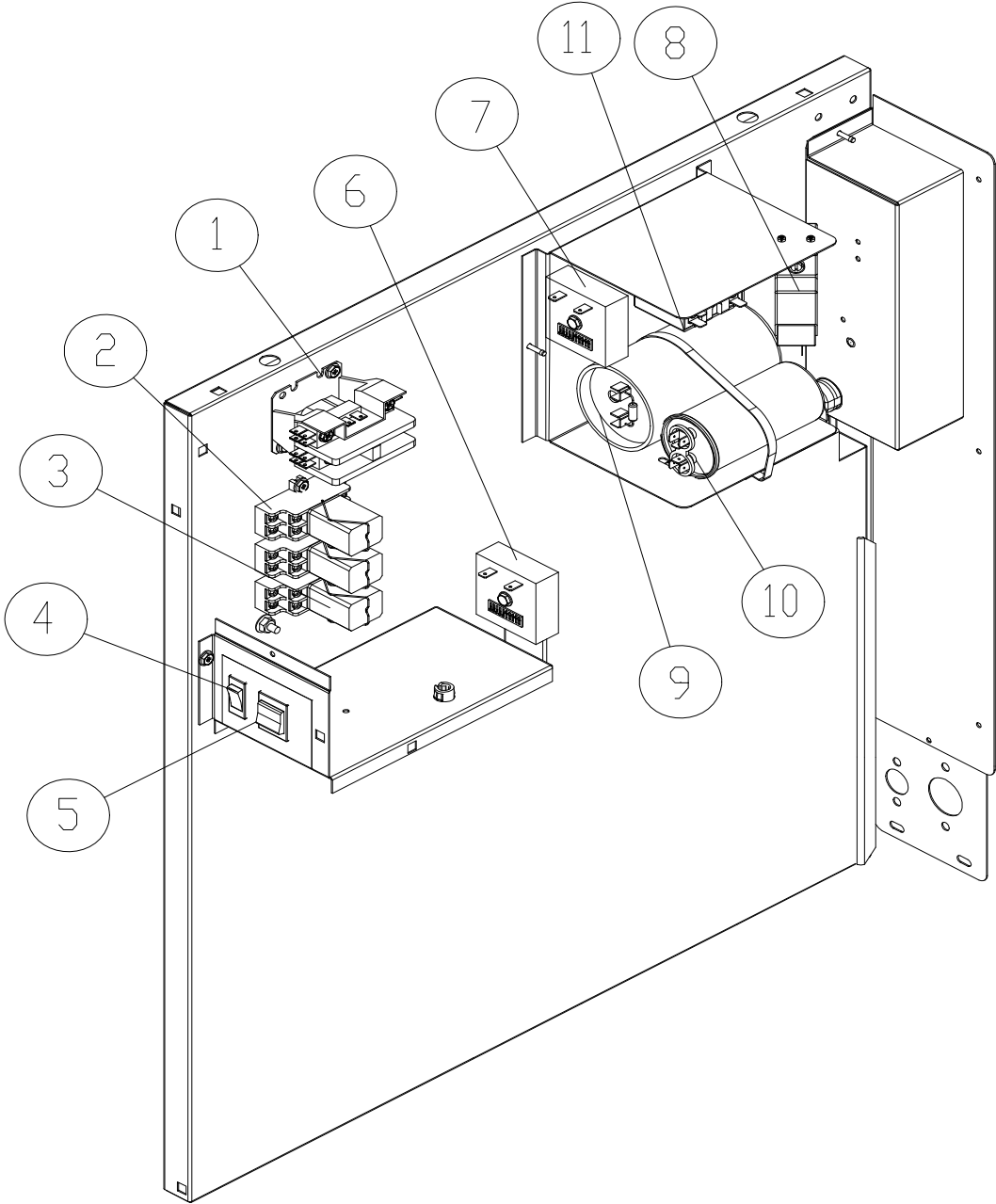

Item No.	Model Number				Description
	ICE1806V3	ICE1807V3	ICE2106V3	ICE2107V3	
1	9101002-06	9101079-02	9101002-06	9101079-02	Contactora
2	9101083-01	9101083-01	9101083-01	9101083-01	Relay Base
3	9101084-02	9101084-02	9101084-02	9101084-02	Relay
4	1051208-01	1051208-01	1051208-01	1051208-01	Purge Switch (9101139-03 is NLA)
5	9101349-01	9101349-01	9101349-01	9101349-01	ICE-OFF-WASH Switch (9101195-01 is NLA)
6	9101148-01	9101148-01	9101148-01	9101148-01	Timer
7	9101148-01	9101148-01	9101148-01	9101148-01	Timer (6 Minute-Remote only)
8	9041104-101A	9041104-101A	9041104-101A	9041104-101A	Low Pressure Control (Timer Initiate)
9	See Below	N/A	See Below	N/A	Start Capacitor
10	See Below	N/A	See Below	N/A	Run Capacitor
11	See Below	N/A	See Below	N/A	Compressor Relay

Reference the Compressor Model Number to INSURE THE CORRECT START COMPONENTS ARE SUPPLIED
 The Compressor Kits below Are NO LONGER AVAILABLE Replaced by the Compressors in Green BELOW

ICE1806V3	ICE1807V3	ICE2106V3	ICE2107V3	
9181108-11	9181108-12	9181129-11	9181129-12	Compressor Kit=No Longer Available
9181003-21	N/A	9181003-21	N/A	Start Capacitor (Still Available)
9181009-20	N/A	9181009-13	N/A	Run Capacitor (Still Available)
9181010-10	N/A	9181010-11	N/A	Relay (Still Available)
9181108-11				CS20K6E-PFV-235
9181108-12		CS20K6E-TF5-236		
9181129-11			CS24K6E-PFV-236	
9181129-12			CS24K6E-TF5-236	

ICE1806V3	ICE1807V3	ICE2106V3	ICE2107V3	
9181143-11	9181143-13	9181144-11	9181144-12	Compressor Kit
9181003-21	N/A	9181003-21	N/A	Start Capacitor
9181009-20	N/A	9181009-13	N/A	Run Capacitor
9181010-10	N/A	9181010-11	N/A	Relay
9181143-11				CS20K6E-PFV-255
9181143-13		CS20K6E-TF5-256		
9181144-11			CS24K6E-PFV-256	
9181144-12			CS24K6E-TF5-256	



1051210-XX Reference Page 11 for Specific Model Number and Part Number

- The **1051210-XX** assembly will fit all ICE Models from October 1999 and EC Models.
- Units installed with a double cam switch, either Field installed or Factory installed will require the complete assembly and a potential wiring change as per the New Wiring Diagram included with the assembly.
- Individual component parts are not available for the **1051210-XX** assembly.
- Individual component parts are No Longer Available for previous version of the Harvest Assist Assembly
- Parts for the **2061962-XX** Harvest Assist Assembly are not compatible with **1051210-XX** Harvest Assist Assembly.
- Proper assembly and alignment of the parts is critical to proper operation, this includes cam and probe alignment.
- If a **1051210-XX** assembly fails, it must be returned to Ice-O-Matic.

Item No.	Model Number				Description
	ICE1806V3	ICE1807V3	ICE2106V3	ICE2107V3	
	1051210-02	1051210-02	1051210-02	1051210-02	Complete Assembly-Right Side
	2061962-02S	2061962-02S	2061962-02S	2061962-02S	No Longer Available
	1051210-03	1051210-03	1051210-03	1051210-03	Complete Assembly-Secondary-Left Side
	2061962-03S	2061962-03S	2061962-03S	2061962-03S	No Longer Available-Secondary-Left Side

LEFT SIDE HARVEST ASSIST (SECONDARY)

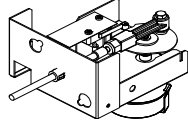
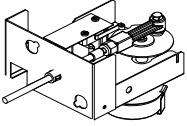

RIGHT SIDE HARVEST ASSIST (PRIMARY)

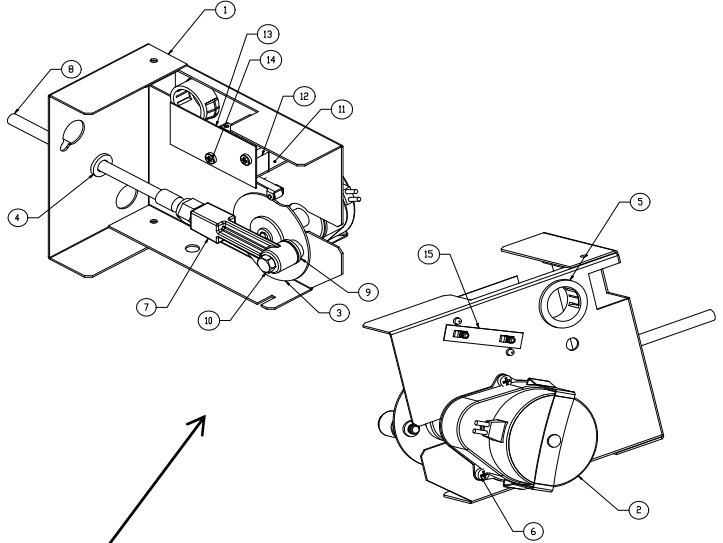

2061962-02S	No Longer Available
2061962-03S	No Longer Available
2061962-10S	No Longer Available

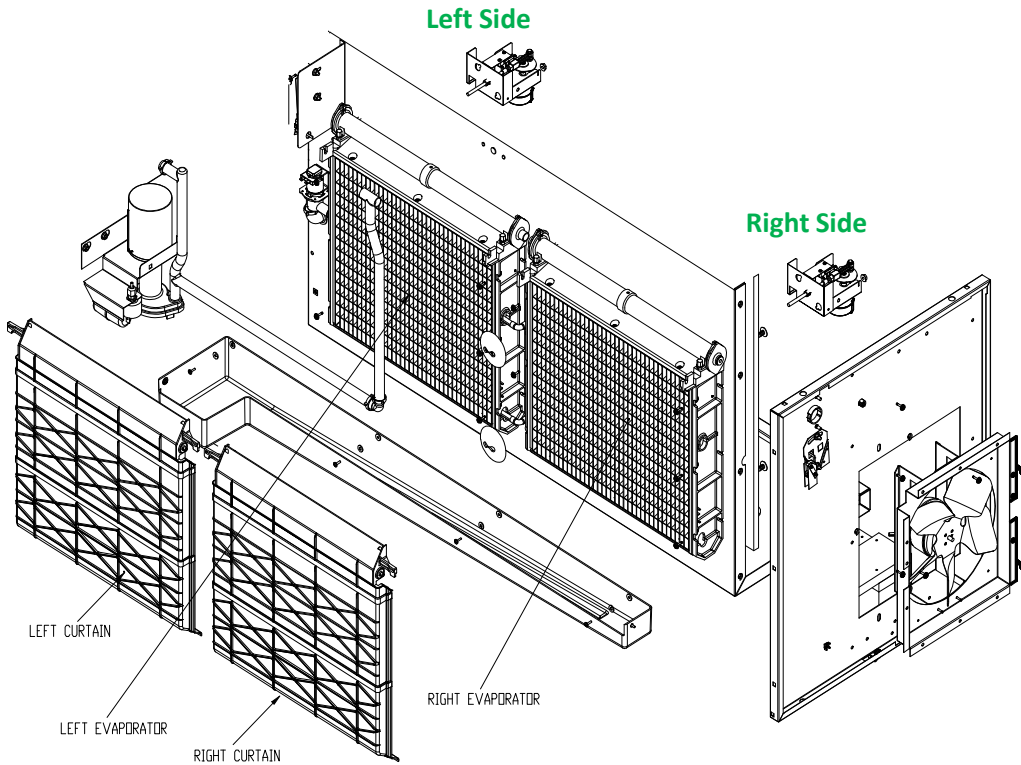

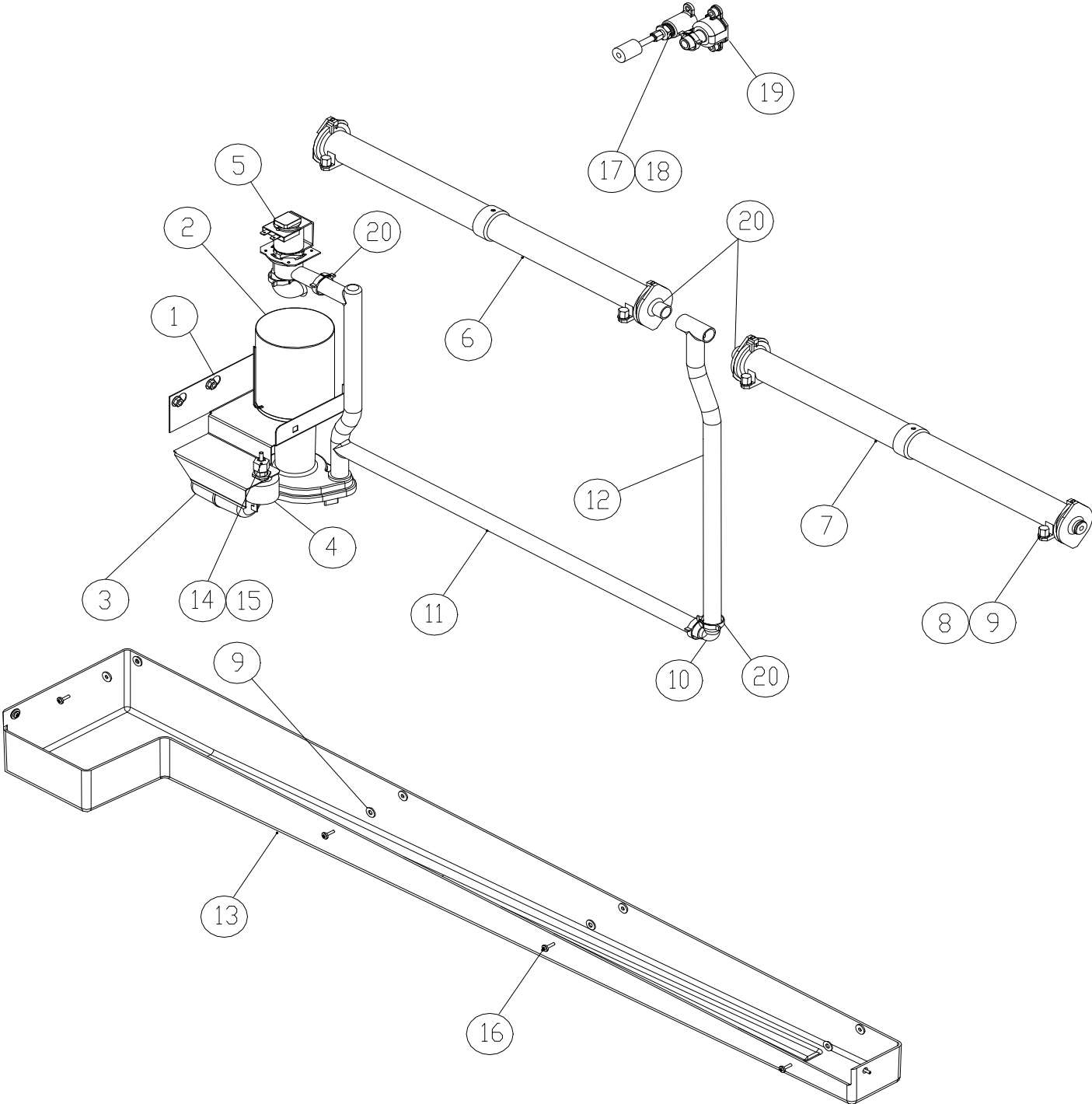

Item No.	Model Number				Description
	ICE1806V3	ICE1807V3	ICE2106V3	ICE2107V3	
1	3013310-01	3013310-01	3013310-01	3013310-01	Water Pump Bracket
2	9161079-06	9161079-06	9161079-06	9161079-06	Water Pump
3	9131111-102	9131111-102	9131111-102	9131111-102	Float (Includes Fittings)
4	9131026-02	9131026-02	9131026-02	9131026-02	Float Deflector
5	9041105-03	9041105-03	9041105-03	9041105-03	Purge Valve (9041086-03 is NLA)
6	2041338-02	2041338-02	2041338-02	2041338-02	Water Distribution Tube Left
7	2041338-01	2041338-01	2041338-01	2041338-01	Water Distribution Tube Right
8	9031122-01	9031122-01	9031122-01	9031122-01	Thumb Screw
9	9031004-19	9031004-19	9031004-19	9031004-19	Washer
10	9091052-01	9091052-01	9091052-01	9091052-01	Elbow
11	9051543-01	9051543-01	9051543-01	9051543-01	Water Pump Tube (Water Pump/Purge Valve)
12	9051546-02	9051546-02	9051546-02	9051546-02	Water Pump Tube (Water Distribution Tube)
13	9051544-01	9051544-01	9051544-01	9051544-01	Water Trough
14	3032898-34	3032898-34	3032898-34	3032898-34	Water Inlet Tubing (34.00 inches long)
15	9091081-01	9091081-01	9091081-01	9091081-01	Sleeve
	9091080-01	9091080-01	9091080-01	9091080-01	Barrel Fitting
16	9031046-24	9031046-24	9031046-24	9031046-24	Water Trough Screw
17	9091074-01	9091074-01	9091074-01	9091074-01	Drop Adapter
18	9091083-01	9091083-01	9091083-01	9091083-01	Water Inlet Fitting
19	9091140-01	9091140-01	9091140-01	9091140-01	Drain Fitting
20	9021010-04	9021010-04	9021010-04	9021010-04	Clamp

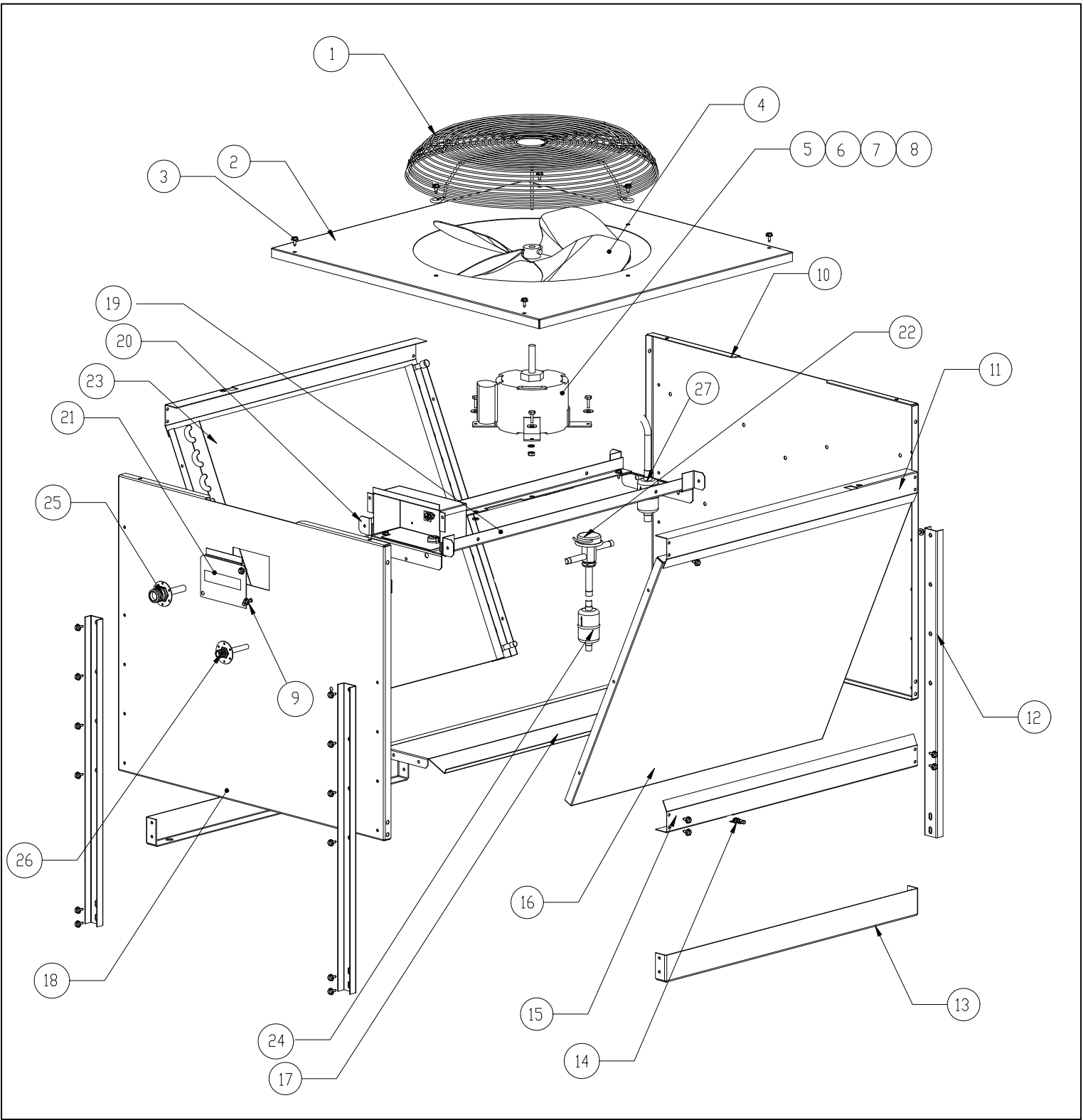

ICE0500R	ICE0600R	ICE0800R ICE1000R	ICE1400R3 ICE1506R3	ICE1800R3 ICE2100R3
----------	----------	----------------------	------------------------	------------------------

Item	VRC1001	VRC1061	VRC2061	VRC2661	VRC5061	Description
1	9131452-01	9131452-01	9131452-01	9131452-01	9131460-01	Fan Guard
2	3013222-01	3013222-01	3013222-01	3013222-01	3013303-01	Top Panel
3	9031019-04	9031019-04	9031019-04	9031019-04	9031019-04	¼-20 x 1/2 Screw
4	9131451-01	9131451-01	9131451-01	9131451-01	9131461-01	Fan Blade
5	9161117-02	9161117-01	9161117-01	9161117-01	9161118-01	Fan Motor
6	9031001-02	9031001-02	9031001-02	9031001-02	9031001-02	¼-20 x ¾ Cap Screw
7	9031003-01	9031003-01	9031003-01	9031003-01	9031003-01	Flat Washer
8	9031118-02	9031118-02	9031118-02	9031118-02	9031118-02	Flanged Lock Nut
9	9031019-04	9031019-04	9031019-04	9031019-04	9031019-04	¼-20 x 1/2 Screw
10	3013224-01	3013224-01	3013224-01	3013224-01	3013224-01	Rear Panel
11	3013226-01	3013226-01	3013226-01	3013226-01	3013305-01	Brace
12	3013227-01	3013227-01	3013227-01	3013227-01	3013227-01	Leg
13	3013228-01	3013228-01	3013228-01	3013228-01	3013306-01	Leg Brace
14	N/A	N/A	N/A	N/A	N/A	T-Nut-Shipping Only
15	3013226-01	3013226-01	3013226-01	3013226-01	3013305-01	Brace
16	3013232-01	3013232-01	N/A	N/A	N/A	Cover Panel
17	3013225-01	3013225-01	3013225-01	3013225-01	3013304-01	Center Panel
18	3013223-01	3013223-01	3013223-01	3013223-01	3013223-01	Front Panel
19	3013234-01	3013234-01	3013234-01	3013234-01	3013307-01	Motor Brace
20	3013233-01	3013233-01	3013233-01	3013233-01	3013233-01	Motor Brace Support
21	3013229-01	3013229-01	3013229-01	3013229-01	3013229-01	Junction Box Cover
22	9151142-02	9151142-02	9151142-02	9151142-02	9151142-02	Mixing Valve
23	9141130-01	9141130-01	9141130-01	9141131-01	9141133-01	Condenser
24	9151143-01	9151143-01	9151143-01	9151143-01	9151143-01	Filter
25	9091001-12	9091001-12	9091001-12	9091001-12	9091001-12	1/2 Coupling
26	9091001-11	9091001-11	9091001-11	9091001-11	9091001-11	3/8 Coupling
27	9151143-02	9151143-02	9151143-02	9151143-02	9151143-02	Filter