



## Ovens

### ADVANCE PLUS ovens

## ADVANCE PLUS OVEN, APE-102

19010816

### DIMENSIONS

		Article	Packed
Length	mm	1.130,00	1.200,00
Depth	mm	1.063,00	1.200,00
Height	mm	1.117,00	1.270,00
Weight	Kg	250,00	270,00
Volumen	m3	1,34	1,83

### ELECTRICITY

Electric power	KW	
230V - I+N		31,20
230V - III		3x25+T - 100 A
400V - III+N		4x10+T - 63 A

### PLUMBING - WATER

Water consumption (lit/h)	40,00
Pressure (Kg/cm2)	2 - 4

### GAS

Not used

### STEAM

Not used

### AIR

Not used

### LEVEL SOUND

(dB) 62,00

### ADVANCE PLUS OVEN, APE-102

Innovative technology in the kitchen :

- Professional quality
- Precision, excellence and perfect results
- Save time and money

Capacity for 20 1/1-GN trays or 10 2/1-GN trays.

"Touch control" screen.

4 cooking methods: Steam, Adjustable Steam (Humidity control during cooking), Regeneration and Convection (up to 300°C).

Preheating option.

Fagor Easy cooking mode.

Fagor Cooking, range of cooking programmes.

Fagor Multi-Tray System, control cooking by tray.

Delayed programming for: Cooking, Low-temperature cooking and Washing.

Memory function: records the different cooking methods used.

3 Speeds - 2 power ranges.

Cold-Down chamber cooling system.

"Auto-reverse" system to reverse fan rotation.

5 wash programmes.

Multisensor temperature probe.

PC management software: History, recipes. HACCP, manuals...

HACCP cooking data recording system.

Steam generator equipped with limescale detector.

Steam generator automatically empties every 24 hours of cooking.

Semi-automatic limescale removal system.

Error detection system. "Repair service" mode system.

IPX-5 protection.

Retractable shower.

Power: 31.2 KW.

Dimensions: 1,130 x 1,063 x 1,117 mm.

Optional elements:

- Structure for trays EB-102
- Structure for dishes EP-102
- Trolley for structure CP-102
- Supports SH-102

Connections points	X	Y	Z	Diameter	Information
ELECTRICITY	957	825	110		
COLD WATER	1.059	625	110	3/4"	
SOFT COLD WATER	989	625	110	3/4"	
DRAIN	683	197	110	30x25	

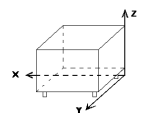

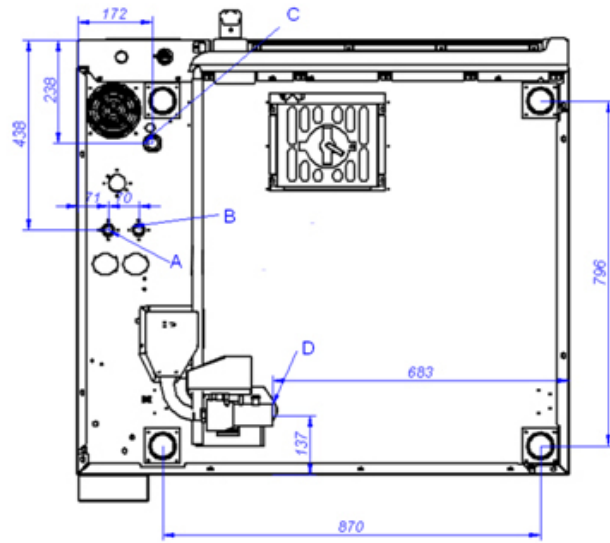
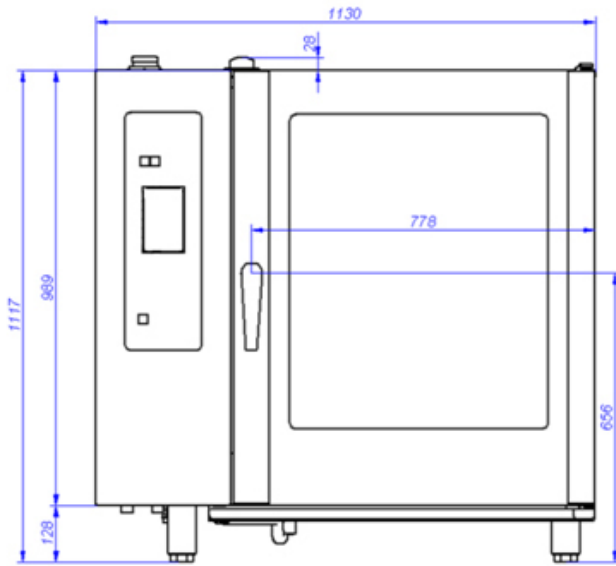

**APE-102**

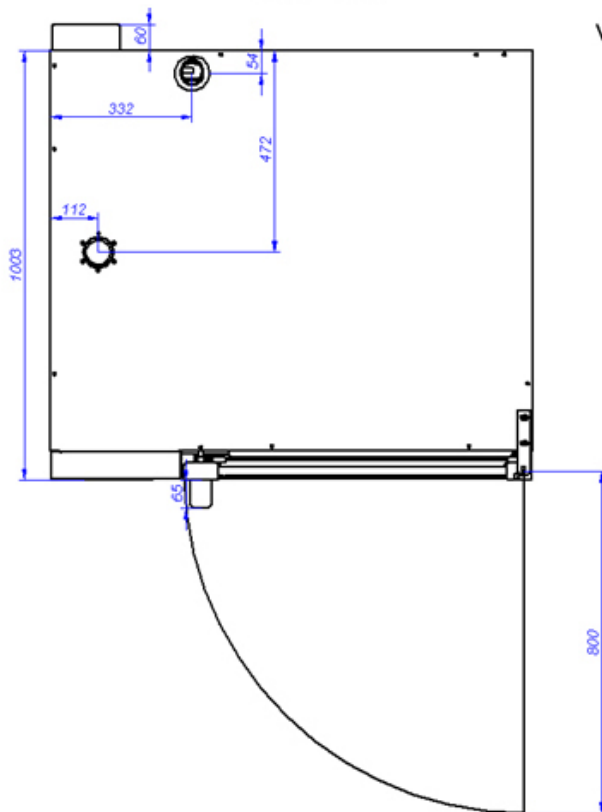

VISTA DE LA BASE DESDE LA PARTE INFERIOR  
VIEW FROM THE BOTTOM OF THE MACHINE

- A: Entrada de agua blanda
- B: Entrada de agua dura
- D: Desagüe

C: Alimentación eléctrica

- A: Soft water inlet
- B: Water inlet
- D: Drain

C: Electrical connection