



CRESCENT CUBER

KM-470AJ
KM-470AWJ

PARTS LIST

[GENERAL][HSH][HPH][HTW][HS][HMY][HID][HTH][HHK]

F136
F136-C101,F136-C301
F150
F150-C101,F150-C401

J-1 JUN. 2019

List of Specifications 规格列表

型号 MODEL	产品代码 MODEL NUMBER	规格 SPEC
KM-470AJ	F136	Standard
KM-470AJ	F136-C101	HSH
KM-470AJ	F136-C301	HPH
KM-470AWJ	F150	HS,HMY,HID,HTH,HHK
KM-470AWJ	F150-C101	HSH
KM-470AWJ	F150-C401	HTW

辅助编码

AUXILIARY CODE

U - 1

辅助编码序列号的前两个字符，第一个字符表示生产年份，年份是按字母顺序依次编码。字母顺序（有时存在字母跳跃）取决于UL认证规则、生产、产品型号。请参考铭牌标签的辅助编码和生产年份进行对应。

The auxiliary code is the first two characters in the serial number. The first character indicates the production year. Years progress or regress in alphabetical order. The series of letters and skipped letters depend on UL listing, production, and model. See the auxiliary code(s) and corresponding year(s) on the front cover.

第二个字符表示在同一生产年份内产品发生了显著的变化，从“1”开始，依次进行变化；如果在1年中产品没有显著的变化，此号码从“0”开始。

The second character indicates significant part changes within the same year. Base is "1" and this number advances for each change.

If there is no significant part change at the turn of the year, this number starts from "0."

紧固件零件编码

FASTENER PART NUMBER

螺丝

SCREWS

F S T 0 3 0 6 F 0



*1 材质 Material

F: 铁 Steel
S: 奥氏体不锈钢 Austenitic stainless steel
M: 马氏体不锈钢 Martensitic stainless steel
B: 铜合金 Copper alloy
P: 聚碳酸酯 Polycarbonate
N: 聚酰胺 Polyamide
V: PVC
A: ABS
X: 聚缩醛 Polyacetal
L: 铝 Aluminum

螺母 & 垫片

NUTS & WASHERS

F W S P 0 5 S 0



*2 描述 Description

首字母 First letter
S: 机器螺丝 Machine screw
T: 自攻螺丝 Tapping screw
M: 木螺丝 Wood screw
B: 螺栓 Bolt
W: 垫片 Washer
N: 螺母 Nut

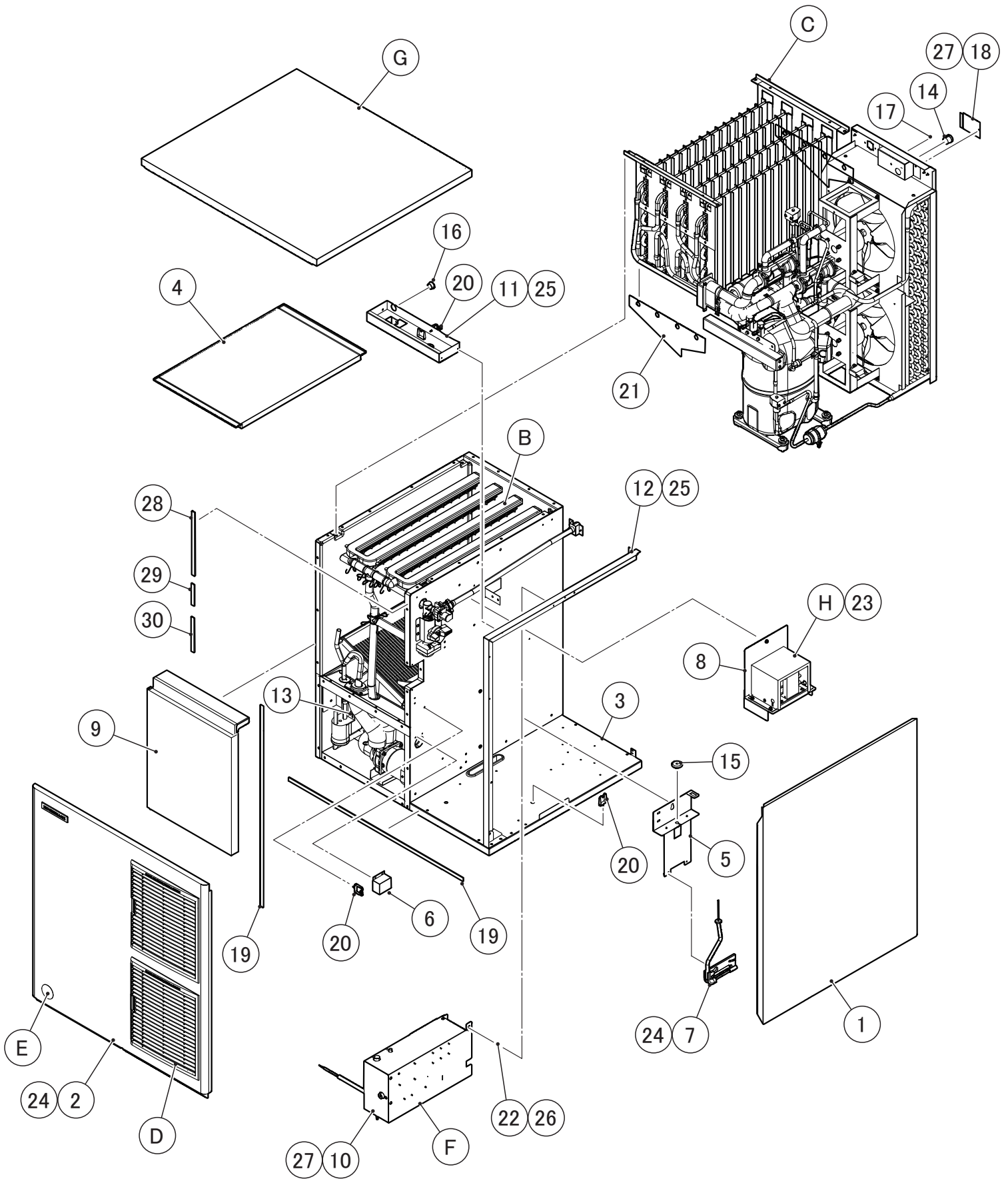

型号/MODEL: **KM-470AJ**

标题/TITLE: **A. ICE CUBER ASSY**
制冰组件

序号 INDEX NO.	部品名称 DESCRIPTION	材质或型号MATERIAL OR MODEL NUMBER	部品序号 PART NUMBER	需求数量 REQ'D NUMBER				
				J-1 and later				
B	WATER CIRCUIT 水回路		127964A01	1				
C	REFRIGERATION CIRCUIT 冷冻回路	F136,F136-C101	127966A01	1				
		F136-C301	127966A02	1				
		F150,F150-C101	128706A01	1				
		F150-C401	128706A02	1				
D	LOUVER FILTER AY 通风窗过滤组件		277614A01	1				
E	LABEL LOCATION 标签位置	F136	277615A01	1				
		F136-C101	277615A02	1				
		F136-C301	277615A03	1				
		F150	280453A01	1				
		F150-C101	280453A02	1				
		F150-C401	280453A05	1				
F	CONTROL BOX AY 控制盒组件	F136	277616A01	1				
		F136-C101	277616A02	1				
		F136-C301	277616A03	1				
		F150	277616A04	1				
		F150-C101	277616A05	1				
		F150-C401	277616A06	1				
G	TOP PANEL AY 顶板组件		389234A01	1				
H	TRANSFORMER BOX AY 变压器盒子组件		389235A01	1				
L	ACCESSORIES 附件	F136,F136-C301,F150	A03765-01	1				
		F136-C101,F150-C101	A03851-01	1				

型号/MODEL: **KM-470AJ**

标题/TITLE: **A. ICE CUBER ASSY**
制冰组件

序号 INDEX NO.	部品名称 DESCRIPTION	材质或型号MATERIAL OR MODEL NUMBER	部品序号 PART NUMBER	需求数量 REQ'D NUMBER				
				J-1 and later				
		F150-C401	A03923-01	1				
1	SIDE PANEL (R) 侧板		127955G01	1				
2	FRONT PANEL (A) 前面板 (A)	F136,F136-C101,F136-C301	127956M01	1				
		F150,F150-C101,F150-C401	127956M02	1				
3	EVAP. CASE 蒸发器保温层		127965G01	1				
4	TOP INSULATION 顶部保温		389231G01	1				
5	BULB HOLDER 灯座		389232G01	1				
6	BARRIER 屏障		389233M01	1				
7	BULB HOLDER 灯座		389136P01	1				
8	TRANSFORMER ASSY BRACKET 变压器组装支架		389195M01	1				
9	FRONT INSULATION 前部保温		389236G01	1				
10	CONTROL BOX COVER 控制盒罩子		389196M01	1				
11	FRAME (C) 面框 (C)		389197M01	1				
12	FRAME 面框		389237G01	1				
13	FLOW SWITCH STOP 流量开关停止		389198M01	1				
14	BUSHING 衬套		420472-05	1				
15	CAPILLARY RING 毛细环		425307-02	1				
16	BUSHING 衬套		428394-04	1				
17	SCREW - GROUNDING 螺丝-接地		433304-02	1				
18	JUNCTION BOX COVER 接线盒罩子		485120M01	1				
19	GASKET 密封条	F136,F136-C101,F136-C301	127963Z01	1				
		F150,F150-C101,F150-C401	128705Z01	1				

型号/MODEL: **KM-470AJ**

标题/TITLE: **A. ICE CUBER ASSY**
制冰组件

序号 INDEX NO.	部品名称 DESCRIPTION	材质或型号MATERIAL OR MODEL NUMBER	部品序号 PART NUMBER	需求数量 REQ'D NUMBER				
				J-1 and later				
20	CLAMP 夹子		P05316-01	9				
21	SPLASH GUARD 挡板		485093P01	1				
22	TAPER COLLAR 锥环		4H0171-01	1				
23	HEX HEAD BOLT (SPRING WASHER AND FLAT WASHER) 六角螺栓(弹簧垫圈和平垫圈)		FBK0510F0	7				
24	TRUSS HEAD SCREW 桁架头螺丝		FST0408S0	3				
25	S-TITE TRUSS HEAD SCREW S-TITE 桁架头螺丝		FTS0410M0	6				
26	FLAT HEAD T2 SCREW 平头T2螺丝		470417-02	1				
27	T2 TRUSS HEAD SCREW T2桁架头螺丝		FT20408S0	8				
28	GASKET 密封条	F136,F136-C101,F136-C301	127963Z02	1				
		F150,F150-C101,F150-C401	128705Z02	1				
29	GASKET 密封条	F136,F136-C101,F136-C301	127963Z03	1				
		F150,F150-C101,F150-C401	128705Z03	1				
30	GASKET 密封条	F136,F136-C101,F136-C301	127963Z04	1				
		F150,F150-C101,F150-C401	128705Z04	1				

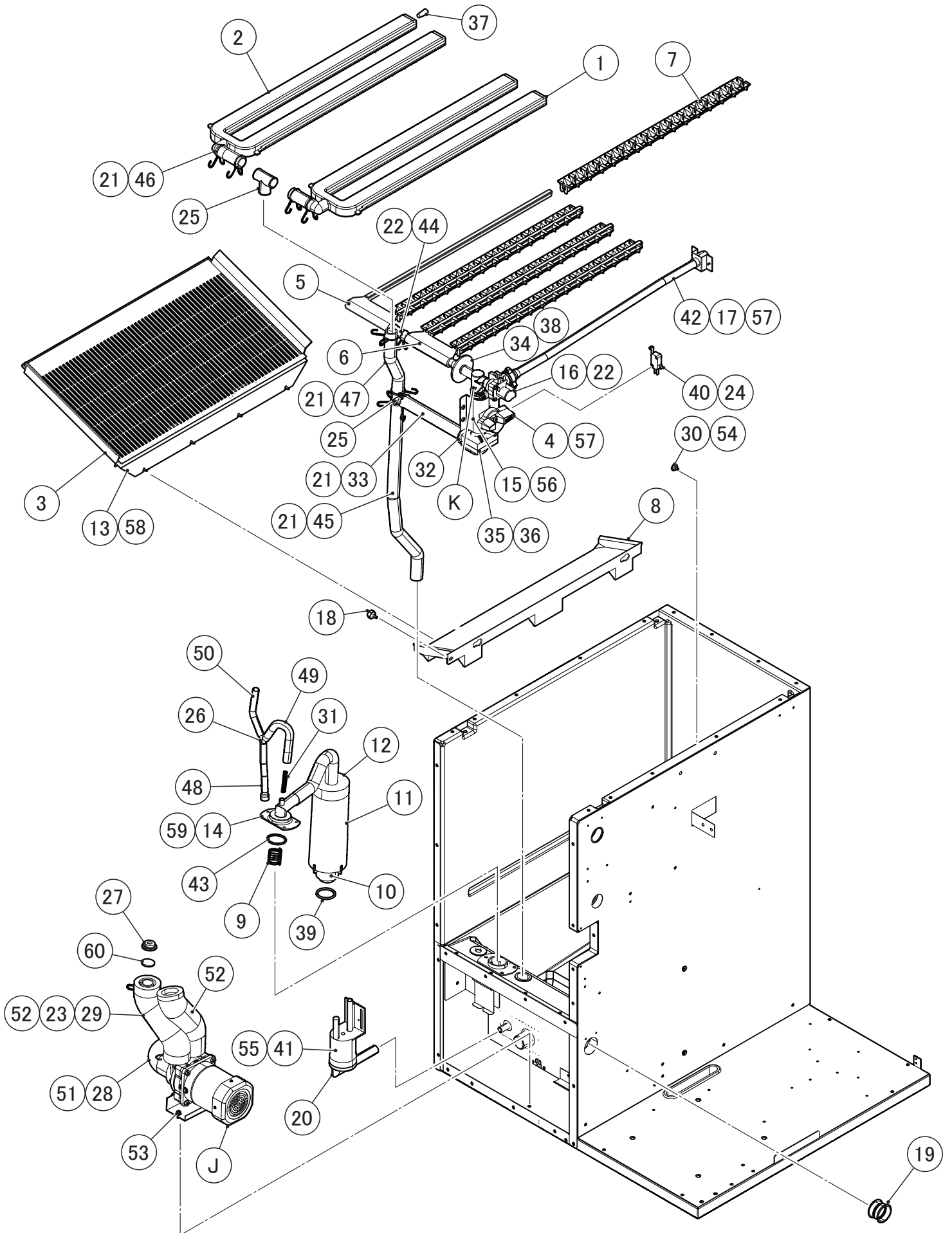

型号/MODEL: **KM-470AJ**

标题/TITLE: **B. WATER CIRCUIT**
水回路

序号 INDEX NO.	部品名称 DESCRIPTION	材质或型号 MATERIAL OR MODEL NUMBER	部品序号 PART NUMBER	需求数量 REQ'D NUMBER				
				J-1 and later				
J	PUMP MOTOR AY 泵马达组件		277617A01	1				
K	BALL VALVE AY 球阀组件		485124A01	1				
1	SPRAY TUBE 散水管		127927P01	1				
2	SPRAY TUBE 散水管		127927P02	1				
3	CUBE GUIDE (A) 导冰 (A)		214905-01	1				
4	HANDLE 把手		277512P01	1				
5	WATER SUPPLY TUBE 供水管		277511P01	1				
6	WATER SUPPLY TUBE 供水管		277511P02	1				
7	SPRAY GUIDE 散水管导板		277513P01	4				
8	CUBE GUIDE (B) 导冰 (B)		389137P01	1				
9	SPRING 弹簧		322685-01	1				
10	OVERFLOW PIPE 溢流管		389138P02	1				
11	OVERFLOW CAP 溢流塞		389139P01	1				
12	HOSE (C) 软管 (C)		389252R01	1				
13	PLATE 金属板		389238M01	1				
14	DRAIN VALVE 排水阀		389140P01	1				
15	VALVE HOLDER 阀支架		389160M01	1				
16	WATER VALVE J248-030 水阀 J248-030		3U0111-01	1				
17	RUBBER GASKET 橡胶密封条		4C0066R01	1				
18	THUMBSCREW 指旋螺丝		415949G10	1				

型号/MODEL: **KM-470AJ**标题/TITLE: **B. WATER CIRCUIT**
水回路

序号 INDEX NO.	部品名称 DESCRIPTION	材质或型号 MATERIAL OR MODEL NUMBER	部品序号 PART NUMBER	需求数量 REQ'D NUMBER				
				J-1 and later				
19	BUSHING 衬套		420470-06	2				
20	CONNECTOR - FLOAT SWITCH 接头-浮子开关		389703R01	1				
21	HOSE CLAMP 软管夹		P02909-03	11				
22	HOSE CLAMP 软管夹		P02909-05	3				
23	HOSE CLAMP 软管夹		P02909-08	2				
24	T2(S) FLANGED PAN HEAD SCREW T2 (S) 法兰盘头螺丝		431415-02	2				
25	DISTRIBUTOR 分流器		485065P01	2				
26	CONNECTOR 接头		485066P01	1				
27	VALVE SEAT 阀座		485074R01	1				
28	HOSE (A) 软管 (A)		435091-01	1				
29	DRAIN HOSE 排水软管		435092-01	1				
30	COLLAR 卡箍		435269-01	2				
31	SPRING 弹簧		435825-01	1				
32	RUBBER RING 橡皮圈		485109R01	1				
33	BYPASS HOSE 旁通软管		485110R01	1				
34	FLANGE 法兰		485111R01	1				
35	CORNER INSULATION (A) 角部保温 (A)		485122Z01	1				
36	CORNER INSULATION (B) 角部保温 (B)		485123Z01	1				
37	PLUG 插头		4C0037R01	4				
38	TEE 三通		485112R01	1				
39	O-RING O型圈		4A1234-01	1				

型号/MODEL: **KM-470AJ**标题/TITLE: **B. WATER CIRCUIT**
水回路

序号 INDEX NO.	部品名称 DESCRIPTION	材质或型号 MATERIAL OR MODEL NUMBER	部品序号 PART NUMBER	需求数量 REQ'D NUMBER				
				J-1 and later				
40	MICRO SWITCH 微动开关		4A2546-01	1				
41	FLOAT SWITCH 浮子开关		4A3624-02	1				
42	WATER SUPPLY PIPE 供水管		HS-0242	1				
43	O-RING O型圈		7611-G035	1				
44	PVC Hose - SOFT PVC软管-软		HE1519050	1				
45	PVC Hose - SOFT PVC软管-软		HE2025470	1				
46	PVC Hose - SOFT PVC软管-软		HE2025065	2				
47	PVC Hose - SOFT PVC软管-软		HE2025170	1				
48	Si Hose 硅胶管		H11013140	1				
49	Si Hose 硅胶管		H11013165	1				
50	Si Hose 硅胶管		H11013115	1				
51	INSULATION TUBE 绝缘套管		H73555110	1				
52	INSULATION TUBE 绝缘套管		H73555180	2				
53	HEX HEAD BOLT (SPRING WASHER AND FLAT WASHER) 六角螺栓(弹簧垫圈和平垫圈)		FBK0512S0	1				
54	FLAT HEAD MACHINE SCREW 平头机械螺丝		FSF0412S0	2				
55	TRUSS HEAD SCREW 桁架头螺丝		FST0408S0	4				
56	S-TITE TRUSS HEAD SCREW S-TITE 桁架头螺丝		FTS0408M0	3				
57	T2 TRUSS HEAD SCREW T2桁架头螺丝		FT20408S0	3				
58	TRUSS HEAD TAPPING SCREW T2 T2桁架头自攻螺丝		FT20410S0	4				
59	T2 TRUSS HEAD SCREW T2 桁架头螺丝		FT20416F0	3				
60	VALVE SEAT (B) 阀座 (B)		486235P01	1				

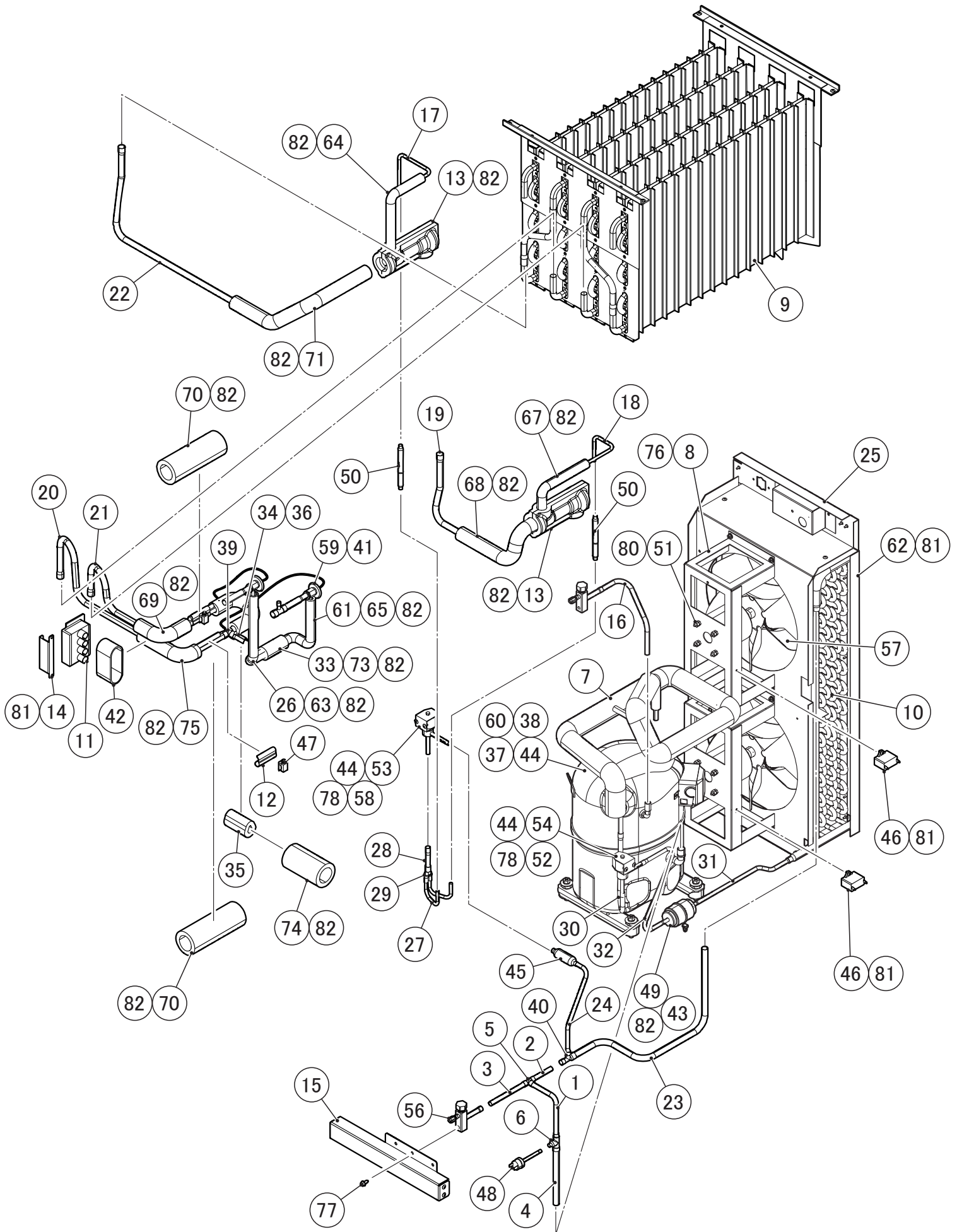

型号/
MODEL: **KM-470AJ**

标题/TITLE: **C. REFRIGERATION CIRCUIT**
冷冻回路

序号 INDEX NO.	部品名称 DESCRIPTION	材质或型号MATERIAL OR MODEL NUMBER	部品序号 PART NUMBER	需求数量 REQ'D NUMBER			
				J-1 and later			
1	COPPER TUBE 90 - BEND 铜管90-折弯	COPPER TUBE (A) - HIGH SIDE 127968G01 铜管(A)-高压侧 127968G01	389217M01	1			
2	TUBE - STRAIGHT 管子-直	COPPER TUBE (A) - HIGH SIDE 127968G01 铜管(A)-高压侧 127968G01	389218M01	1			
3	TUBE - STRAIGHT 管子-直	COPPER TUBE (A) - HIGH SIDE 127968G01 铜管(A)-高压侧 127968G01	389218M02	1			
4	TUBE - STRAIGHT 管子-直	COPPER TUBE (A) - HIGH SIDE 127968G01 铜管(A)-高压侧 127968G01	389218M03	1			
5	TEE 三通	COPPER TUBE (A) - HIGH SIDE 127968G01 铜管(A)-高压侧 127968G01	436000-02	1			
6	TEE 三通	COPPER TUBE (A) - HIGH SIDE 127968G01 铜管(A)-高压侧 127968G01	420335-01	1			
7	HEAT EXCHANGER 热交换		127969G01	1			
8	FAN MOTOR BRACKET 风扇马达支架		127960M01	2			
9	EVAPORATOR 蒸发器		127970G01	1			
10	CONDENSER 冷凝器		P05152-01	1			
11	INSULATED RUBBER TUBE AY 绝缘胶管 组件		389244G01	1			
12	HOLDER - EXP. VALVE 3/8 支架- 膨胀阀3/8		3C0058M01	2			
13	EXPANSION VALVE COVER 膨胀阀罩子		3A0944-01	2			
14	INSULATION - HOLDER 保温-支架		389427M01	1			
15	FRAME (F) 面框 (F)		389203M01	1			
16	COPPER TUBE - SERVICE VALVE 铜管-截止阀		389428M01	1			
17	COPPER TUBE (L) - HOT GAS 铜管(L)-热气		389205M01	1			
18	COPPER TUBE (R) - HOT GAS 铜管(R)-热气		389206M01	1			
19	COPPER TUBE (R1) - LOW SIDE 铜管(R1)-低压侧		389207M01	1			
20	COPPER TUBE (L2) - LOW SIDE 铜管(L2)-低压侧		389208M01	1			

型号/
MODEL: **KM-470AJ**

标题/TITLE: **C. REFRIGERATION CIRCUIT**
冷冻回路

序号 INDEX NO.	部品名称 DESCRIPTION	材质或型号MATERIAL OR MODEL NUMBER	部品序号 PART NUMBER	需求数量 REQ'D NUMBER			
				J-1 and later			
21	COPPER TUBE (R2) - LOW SIDE 铜管(R2)-低压侧		389209M01	1			
22	COPPER TUBE (L1) - LOW SIDE 铜管(L1)-低压侧		389210M01	1			
23	COPPER TUBE (B) - HIGH SIDE 铜管(B)-高压侧		389211M01	1			
24	COPPER TUBE (A1) - HIGH SIDE 铜管(A1)-高压侧		389212M01	1			
25	SHROUD 罩子		389246G01	1			
26	COPPER TUBE (L) - EXP 铜管(L)-膨胀阀		389213M01	1			
27	COPPER TUBE (B) - HOT GAS 铜管(B)-热气	COPPER TUBE - HOT GAS 389225G01 铜管-热气 389225G01	389247M01	2			
28	COPPER TUBE (A) - HOT GAS 铜管(A)-热气	COPPER TUBE - HOT GAS 389225G01 铜管-热气 389225G01	389225M01	1			
29	Y JOINT Y 接头	COPPER TUBE - HOT GAS 389225G01 铜管-热气 389225G01	4A0159-01	1			
30	COPPER TUBE (F) - HIGH SIDE 铜管(F)-高压侧		389214M01	1			
31	COPPER TUBE (C) - HIGH SIDE 铜管(C)-高压侧		389215M01	1			
32	COPPER TUBE - LINE VALVE 铜管-管路阀		389216M01	1			
33	TEE 三通		420041-16	1			
34	HOLDER - THERMISTOR 支架-热敏电阻		427430-01	1			
35	INSULATION - THERMISTOR 绝缘-热敏电阻		485131Z01	1			
36	THERMISTOR 热敏电阻		429006-03	1			
37	SPACER 垫片		434921-01	4			
38	GROMMET 环垫		434922-01	4			
39	TEE 三通		436000-03	1			
40	TEE 三通		436000-09	1			
41	TEE 三通		436000-10	2			

型号/
MODEL: **KM-470AJ**

标题/TITLE: **C. REFRIGERATION CIRCUIT**
冷冻回路

序号 INDEX NO.	部品名称 DESCRIPTION	材质或型号MATERIAL OR MODEL NUMBER	部品序号 PART NUMBER	需求数量 REQ'D NUMBER			
				J-1 and later			
42	INSULATION 保温材料		485121Z01	1			
43	CABLE TIE MOUNT 电线扎带安装		437618-01	1			
44	BOLT 螺栓		437889-01	4			
45	STRAINER 滤芯		441569-02	1			
46	CAPACITOR 电容		P05273-02	2			
47	CLAMP 夹子		443461-02	2			
48	PRESSURE SWITCH 压力开关		P05220-04	1			
49	DRIER 干燥器		P02070-01	1			
50	CHECK VALVE 止回阀		4A1373-01	2			
51	FAN MOTOR-HARNESS 风扇马达-线束		389850G01	2			
52	VALVE BODY 阀体		4A3276-01	1			
53	HOT GAS VALVE COIL-HARNESS 热气阀线圈-线束		389847G01	1			
54	LINE VALVE COIL-HARNESS 管路阀线圈-线束		389848G01	1			
55	BOLT 螺栓		4A3277F01	2			
56	SERVICE VALVE 截止阀		4A3420-01	2			
57	FAN BLADE 扇叶		4A3959-01	2			
58	VALVE BODY 阀体		4A3978-01	1			
59	EXPANSION VALVE 膨胀阀		4A4008-01	2			
60	COMPRESSOR 压缩机	F136,F136-C101	4A4954-03	1			
		F136-C301	4A1539-03	1			
61	COPPER TUBE (R) - EXP. VALVE 铜管 (R)-膨胀阀		485100M01	1			

型号/
MODEL: **KM-470AJ**

标题/TITLE: **C. REFRIGERATION CIRCUIT**
冷冻回路

序号 INDEX NO.	部品名称 DESCRIPTION	材质或型号MATERIAL OR MODEL NUMBER	部品序号 PART NUMBER	需求数量 REQ'D NUMBER			
				J-1 and later			
62	BARRIER (B) 屏障 (B)		485101M01	1			
63	INSULATION TUBE 绝缘套管		H71020210	1			
64	INSULATION TUBE 绝缘套管		H71020240	1			
65	INSULATION TUBE 绝缘套管		H71020225	1			
66	INSULATION TUBE 绝缘套管		H71020180	1			
67	INSULATION TUBE 绝缘套管		H71020115	1			
68	INSULATION TUBE 绝缘套管		H71630260	1			
69	INSULATION TUBE 绝缘套管		H71630130	1			
70	INSULATION TUBE 绝缘套管		H71630150	1			
71	INSULATION TUBE 绝缘套管		H71630370	1			
72	INSULATION TUBE 绝缘套管		H71630180	1			
73	INSULATION TUBE 绝缘套管		H71630060	1			
74	INSULATION TUBE 绝缘套管		H73555100	1			
75	INSULATION TUBE 绝缘套管		H73555150	2			
76	HEX HEAD BOLT (SPRING WASHER AND FLAT WASHER) 六角螺栓 (弹簧垫圈和平垫圈)		FBK0510F0	8			
77	HEX HEAD TAPPING SCREW 六角自攻螺丝		7B0311412	2			
78	TRUSS HEAD SCREW 桁架头螺丝		FST0408S0	4			
79	TRUSS HEAD SCREW 桁架头螺丝		FST0508S0	1			
80	SELF-LOCKING NUT 自锁螺母		7N2110832	8			
81	T2 TRUSS HEAD SCREW T2桁架头螺丝		FT20408S0	24			
82	NYLON TIE 尼龙扎带		7920-0010	43			

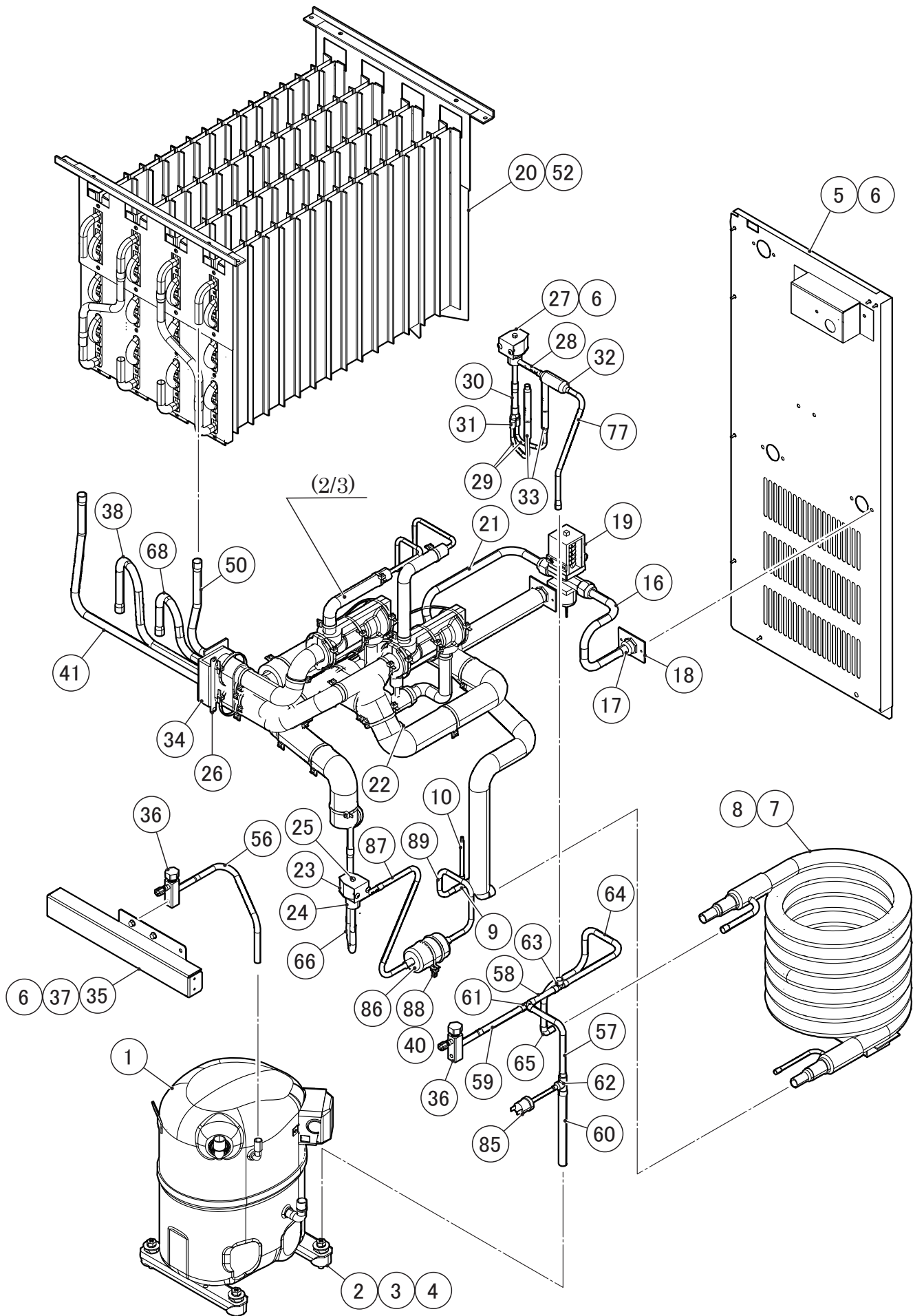

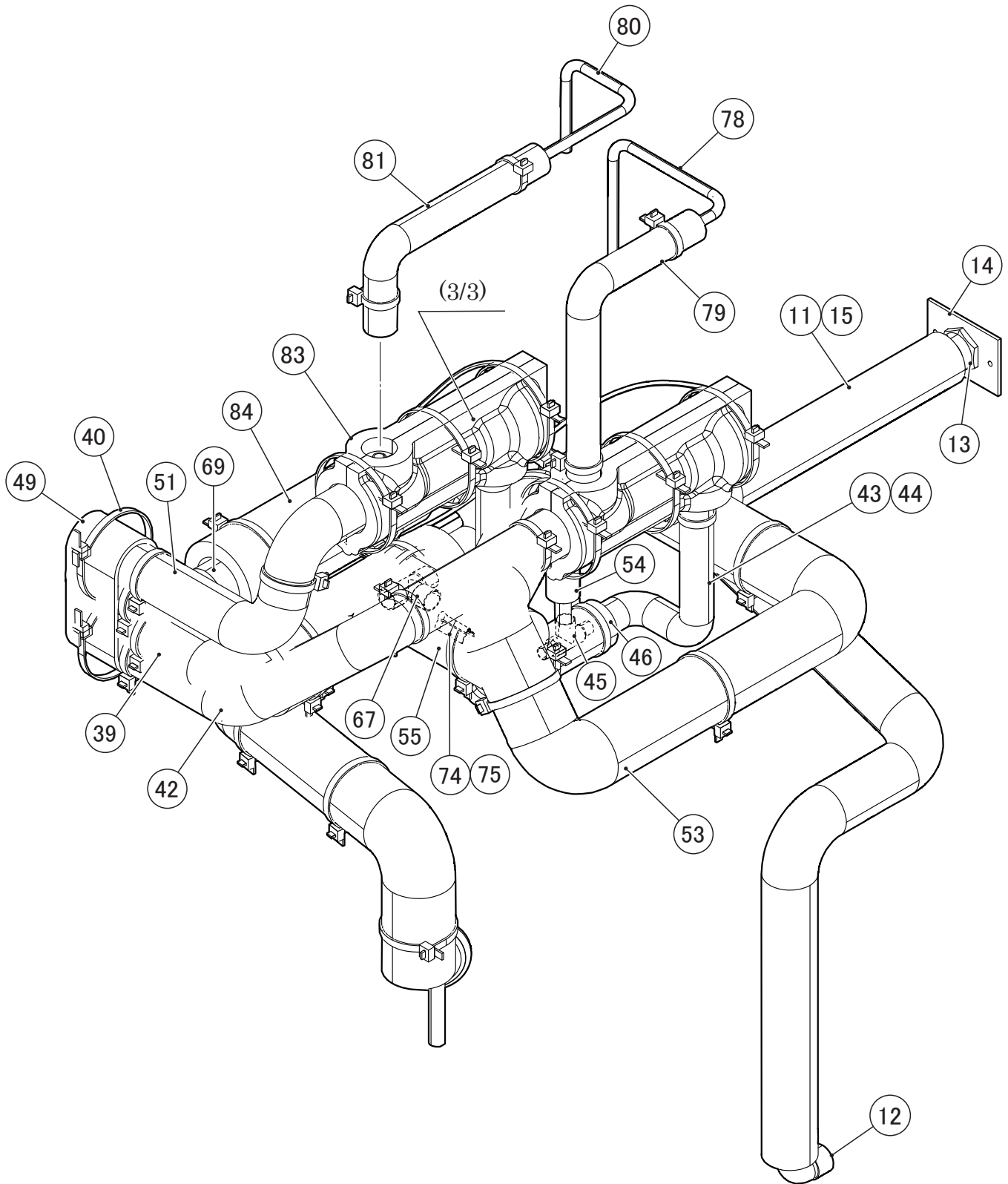

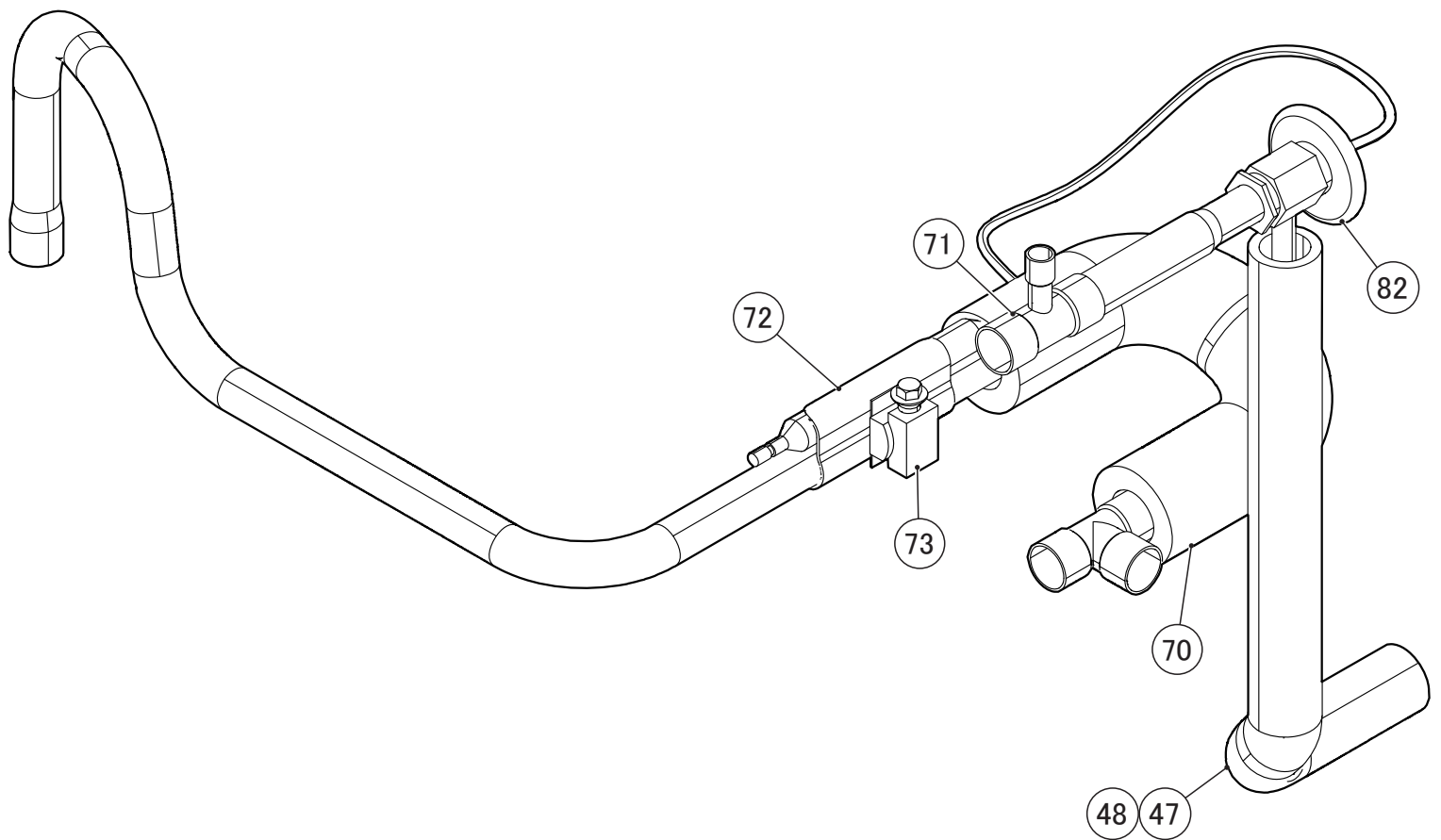

型号/
MODEL: **KM-470AWJ**

标题/TITLE: **C. REFRIGERATION CIRCUIT**
冷冻回路

序号 INDEX NO.	部品名称 DESCRIPTION	材质或型号MATERIAL OR MODEL NUMBER	部品序号 PART NUMBER	需求数量 REQ'D NUMBER			
				L-1 and later			
1	COMPRESSOR	F150,F150-C101	4A4954-03	1			
	压缩机	F150-C401	4A1539-03	1			
2	GROMMET 密封条		434922-01	4			
3	SPACER 垫片		434921-01	4			
4	BOLT 螺栓		437889-01	4			
5	REAR PANEL 后背板		279624G01	1			
6	T2 TRUSS HEAD SCREW T2 大圆头螺丝		FT20408F0	18			
7	CONDENSER - WATER COOLED 冷凝器-水冷		P05527-01	1			
8	HEX HEAD BOLT (SPRING WASHER AND FLAT WASHER) 六角螺栓(弹簧垫圈和平垫圈)		FBK0510S0	2			
9	TEE 三通		420041-02	1			
10	COPPER TUBE (B) - CAPILLARY 铜管 (B)-毛细管		446047-02	1			
11	COPPER TUBE (A1) - WATER CIRCUIT 铜管 (A1)-水回路	COPPER TUBE (A) - WATER CIRCUIT 390991G01 铜管 (A)-水回路 390991G01	390991M01	1			
12	ELBOW 弯头	COPPER TUBE (A) - WATER CIRCUIT 390991G01 铜管 (A)-水回路 390991G01	417395-04	1			
13	INLET FITTING 入口接头配件	COPPER TUBE (A) - WATER CIRCUIT 390991G01 铜管 (A)-水回路 390991G01	P01214-01	1			
14	FITTING HOLDER 配件支架	COPPER TUBE (A) - WATER CIRCUIT 390991G01 铜管 (A)-水回路 390991G01	4A0764-01	1			
15	Insulation Tube 绝缘套管	COPPER TUBE (A) - WATER CIRCUIT 390991G01 铜管 (A)-水回路 390991G01	H71333740	1			
16	COPPER TUBE (C1) - WATE CIRCUIT 铜管 (C1)-水回路	COPPER TUBE (C) - WATER CIRCUIT 390993G01 铜管 (C)-水回路 390993G01	390993M01	1			

型号/
MODEL: **KM-470AWJ**

标题/TITLE: **C. REFRIGERATION CIRCUIT**
冷冻回路

序号 INDEX NO.	部品名称 DESCRIPTION	材质或型号MATERIAL OR MODEL NUMBER	部品序号 PART NUMBER	需求数量 REQ'D NUMBER				
				L-1 and later				
17	INLET FITTING 入口接头配件	COPPER TUBE (C) - WATER CIRCUIT 390993G01 铜管 (C)-水回路 390993G01	P01214-01	1				
18	FITTING HOLDER 配件支架	COPPER TUBE (C) - WATER CIRCUIT 390993G01 铜管 (C)-水回路 390993G01	4A0764-01	1				
19	WATER REGULATOR 水压调节阀	F150,F150-C101	P04030-01	1				
		F150-C401	P05010-01	1				
20	TRUSS HEAD SCREW 大圆头螺丝		FST0408S0	10				
21	COPPER TUBE (B1) - WATER CIRCUIT 铜管 (B1)-水回路	COPPER TUBE (B) - WATER CIRCUIT 390992G01 铜管 (C)-水回路 390992G01	390992M01	1				
22	ELBOW 弯头	COPPER TUBE (B) - WATER CIRCUIT 390992G01 铜管 (C)-水回路 390992G01	417395-04	1				
23	LINE VALVE COIL-HARNESS 管路阀线圈-线束		389848G01	1				
24	VALVE BODY 阀本体		4A3276-01	1				
25	BOLT 螺栓		4A3277F01	2				
26	INSULATION - HOLDER 保温-支架		389427M01	1				
27	HOT GAS VALVE COIL- HARNESS 热气体阀线圈-线束		389847G01	1				
28	VALVE BODY 阀本体		4A3978-01	1				
29	COPPER TUBE (B) - HOT GAS 铜管 (B)-热气	COPPER TUBE - HOT GAS 389225G01 铜管-热气 389225G01	389247M01	2				
30	COPPER TUBE (A) - HOT GAS 铜管 (A)-热气	COPPER TUBE - HOT GAS 389225G01 铜管-热气 389225G01	389225M01	1				
31	Y JOINT Y接头	COPPER TUBE - HOT GAS 389225G01 铜管-热气 389225G01	4A0159-01	1				
32	STRAINFR 滤芯		441569-02	1				

型号/
MODEL: **KM-470AWJ**

标题/TITLE: **C. REFRIGERATION CIRCUIT**
冷冻回路

序号 INDEX NO.	部品名称 DESCRIPTION	材质或型号MATERIAL OR MODEL NUMBER	部品序号 PART NUMBER	需求数量 REQ'D NUMBER			
				L-1 and later			
33	CHECK VALVE 止回阀		4A1373-01	2			
34	INSULATED RUBBER TUBE AY 保温橡胶管AY		389244G01	1			
35	FRAME (F) 框架 (F)		389203M01	1			
36	SERVICE VALVE 检修阀		4A3420-01	2			
37	HEX HEAD TAPPING SCREW 六角自攻螺丝		7B03I1412	2			
38	COPPER TUBE (L2) - LOW SIDE 铜管 (L2)-低压侧		389208M01	1			
39	Insulation Tube 绝缘套管		H71630150	1			
40	NYLON TIE 尼龙扎带		7920-0010	43			
41	COPPER TUBE (L1) - LOW SIDE 铜管 (L2)-低压侧		389210M01	1			
42	Insulation Tube 绝缘套管		H71630370	1			
43	COPPER TUBE (R) - EXP. VALVE 铜管 (R)-膨胀阀		485100M01	1			
44	INSULATION TUBE 绝缘套管		H71020225	1			
45	TEE 三通		420041-16	1			
46	Insulation Tube 绝缘套管		H71630060	1			
47	COPPER TUBE (L) - EXP 铜管 (L)-膨胀阀		389213M01	1			
48	INSULATION TUBE 绝缘套管		H71020210	1			
49	INSULATION 保温		485121Z01	1			
50	COPPER TUBE (R1) - LOW SIDE 铜管 (R1)-低压侧		389207M01	1			

型号/
MODEL: **KM-470AWJ**

标题/TITLE: **C. REFRIGERATION CIRCUIT**
冷冻回路

序号 INDEX NO.	部品名称 DESCRIPTION	材质或型号MATERIAL OR MODEL NUMBER	部品序号 PART NUMBER	需求数量 REQ'D NUMBER				
				L-1 and later				
51	Insulation Tube 绝缘套管		H71630260	1				
52	EVAPORATOR 蒸发器		127970G01	1				
53	HEAT EXCHANGER 热交换		127969G01	1				
54	Insulation Tube 绝缘套管		H71020180	1				
55	Insulation Tube 绝缘套管		H73555100	1				
56	COPPER TUBE - SERVICE VALVE 铜管-检修阀		389428M01	1				
57	COPPER TUBE 90 - BEND 铜管90-折弯	COPPER TUBE (A) - HIGH SIDE 127968G01 铜管 (A)-高压侧 127968G01	389217M01	1				
58	TUBE - STRAIGHT 管子-直	COPPER TUBE (A) - HIGH SIDE 127968G01 铜管 (A)-高压侧 127968G01	389218M01	1				
59	TUBE - STRAIGHT 管子-直	COPPER TUBE (A) - HIGH SIDE 127968G01 铜管 (A)-高压侧 127968G01	389218M02	1				
60	TUBE - STRAIGHT 管子-直	COPPER TUBE (A) - HIGH SIDE 127968G01 铜管 (A)-高压侧 127968G01	389218M03	1				
61	TEE 三通	COPPER TUBE (A) - HIGH SIDE 127968G01 铜管 (A)-高压侧 127968G01	436000-02	1				
62	TEE 三通	COPPER TUBE (A) - HIGH SIDE 127968G01 铜管 (A)-高压侧 127968G01	420335-01	1				
63	TEE 三通		436000-02	1				
64	COPPER TUBE (B1) - HIGH SIDE 铜管 (B1)-高压侧	COPPER TUBE (B) - HIGH SIDE 390964G01 铜管 (B)-高压侧 390964G01	390964M01	1				
65	ELBOW 弯头	COPPER TUBE (B) - HIGH SIDE 390964G01 铜管 (B)-高压侧 390964G01	419753-01	1				
66	COPPER TUBE (F) - HIGH SIDE 铜管 (F)-高压侧		389214M01	1				
67	TEE 三通		436000-03	1				

型号/
MODEL: **KM-470AWJ**

标题/TITLE: **C. REFRIGERATION CIRCUIT**
冷冻回路

序号 INDEX NO.	部品名称 DESCRIPTION	材质或型号MATERIAL OR MODEL NUMBER	部品序号 PART NUMBER	需求数量 REQ'D NUMBER				
				L-1 and later				
68	COPPER TUBE (R2) - LOW SIDE 铜管 (R2)-低压侧		389209M01	1				
69	Insulation Tube 绝缘套管		H71630130	1				
70	Insulation Tube 绝缘套管		H71630180	1				
71	TEE 三通		436000-10	2				
72	HOLDER - EXP. VALVE 3/8 支架-膨胀阀3/8		3C0058M01	2				
73	CLAMP 卡箍		443461-02	2				
74	HOLDER - THERMISTOR 支架-热敏电阻		427430-01	1				
75	THERMISTOR 热敏电阻		429006-03	1				
76	INSULATION - THERMISTOR 保温-热敏电阻		485131Z01	1				
77	COPPER TUBE (A1) - HIGH SIDE 铜管 (A1)-高压侧		389212M01	1				
78	COPPER TUBE (L) - HOT GAS 铜管 (L)-热气		389205M01	1				
79	INSULATION TUBE 绝缘套管		H71020115	1				
80	COPPER TUBE (R) - HOT GAS 铜管 (R)-热气		389206M01	1				
81	INSULATION TUBE 绝缘套管		H71020240	1				
82	EXPANSION VALVE 膨胀阀		4A4008-01	2				
83	EXPANSION VALVE COVER 膨胀阀罩子		3A0944-01	2				
84	INSULATION TUBE 绝缘套管		H73555150	2				
85	PRESSURE SWITCH 压力开关	F150,F150-C101	P05220-05	1				

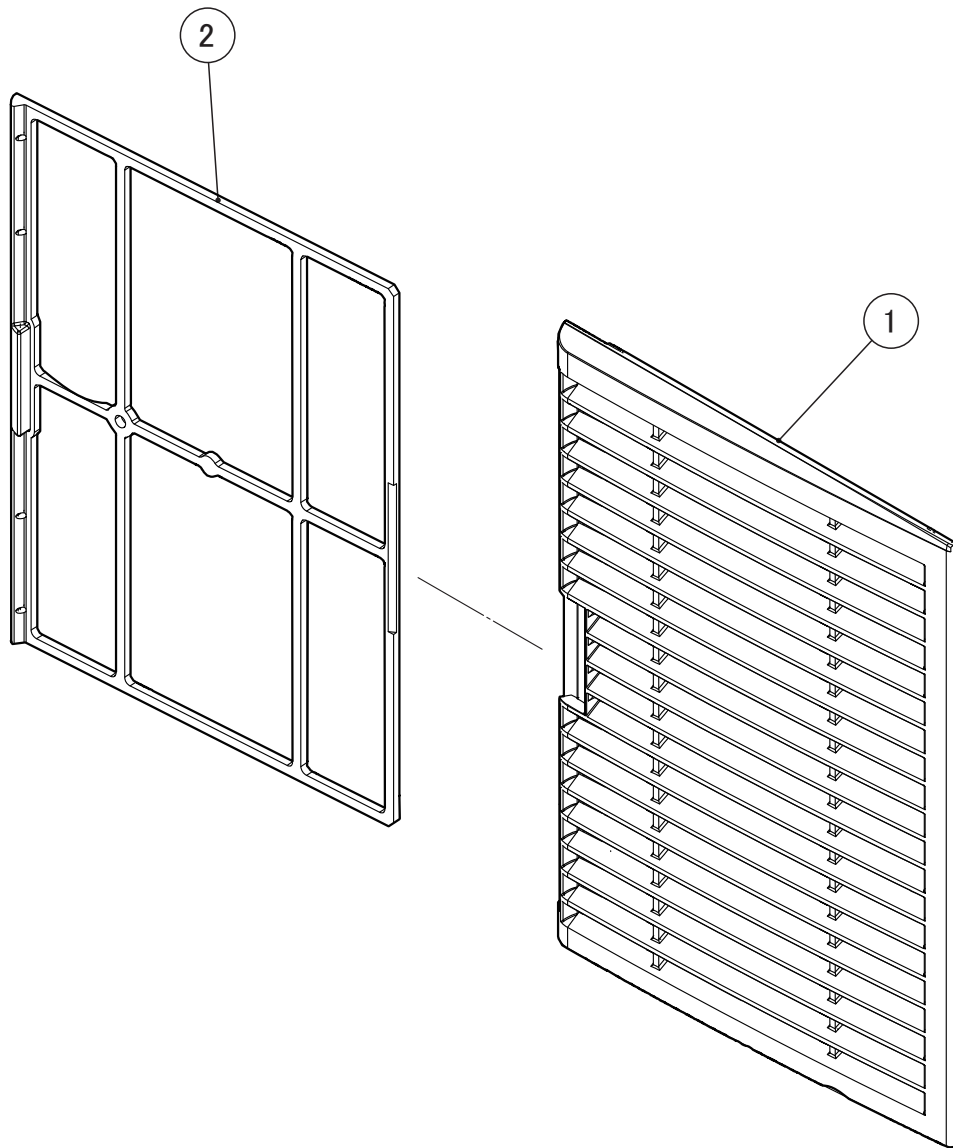

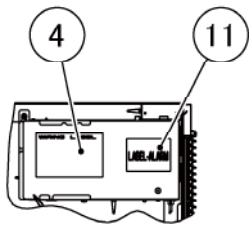

VIEW A

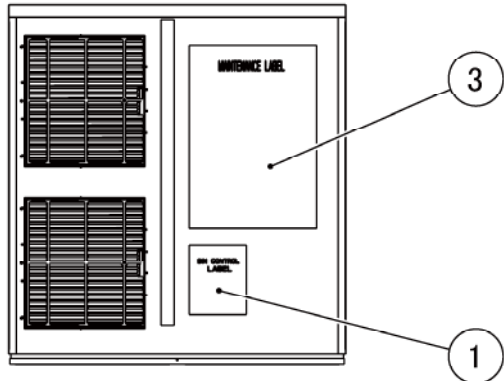

BACK SIDE OF FRONT PANEL

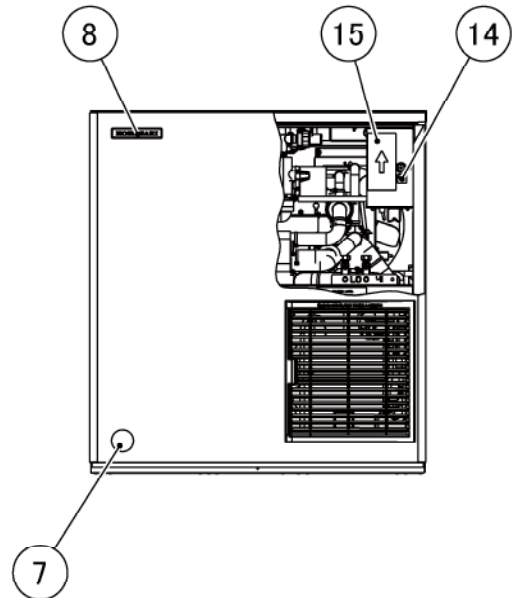
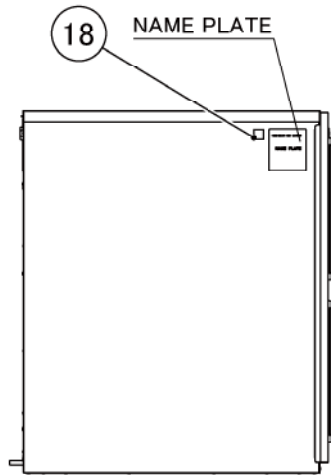
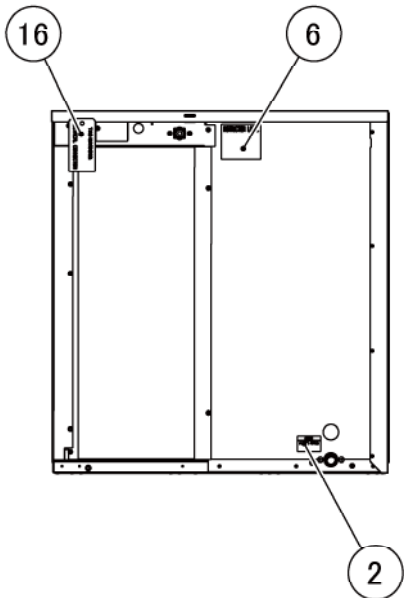
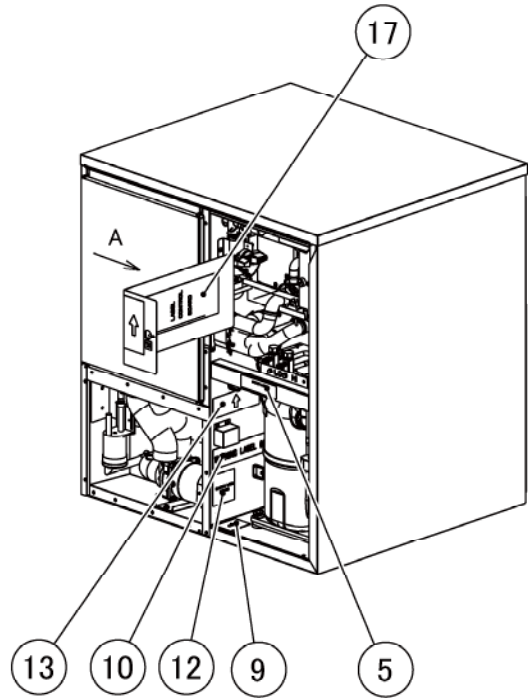

型号/MODEL: **KM-470AJ**

标题/TITLE: **E. LABEL LOCATION**

标签位置

序号 INDEX NO.	部品名称 DESCRIPTION	材质或型号 MATERIAL OR MODEL NUMBER	部品序号 PART NUMBER	需求数量 REQ'D NUMBER				
				J-1 and later				
1	MANUAL LABEL - BIN CONTROL	F136,F136-C301,F150	389485L01	1				
	手动标签-储冰箱控制	F136-C101 F150-C101,F150-C401	391905L01	1				
2	NOTICE LABEL - PLASTIC FITTING	F136,F136-C301,F150	389486L01	1				
	警告标签-塑料配件	F136-C101 F150-C101,F150-C401	391906L01	1				
3	MAINTENANCE LABEL	F136,F136-C301,F150	389487L01	1				
	维修标签	F136-C101 F150-C101,F150-C401	391907L01	1				
4	WIRING LABEL	F136,F150	389479L01	1				
	配线标签	F136-C101,F150-C101	391908L01	1				
		F136-C301,F150-C401	392088L01	1				
5	CAUTION LABEL	F136,F136-C301,F150	485267L01	1				
	警示标签	F136-C101 F150-C101,F150-C401	486443L01	1				
6	INSTRUCTION LABEL	F136,F136-C301,F150	485268L01	1				
	指示标签	F136-C101 F150-C101,F150-C401	486444L01	1				
7	CHARACTER LABEL - PENGUIN 特征标签-企鹅		475552L02	1				
8	EMBLEM 徽章		340842-01	1				
9	PROCESS VALVE LABEL	F136,F136-C301,F150	485269L01	1				
	工艺阀标签	F136-C101 F150-C101,F150-C401	486445L01	1				
10	WARNING LABEL (K)	F136,F136-C301,F150	485270L01	1				
	警告标签 (K)	F136-C101 F150-C101,F150-C401	486446L01	1				
11	LABEL - ALARM	F136,F136-C301,F150	485271L01	1				
	标签-警报	F136-C101 F150-C101,F150-C401	486447L01	1				
12	CAUTION LABEL - SERVICE	F136,F136-C301,F150	471180L01	1				
	警示标签-维修	F136-C101 F150-C101,F150-C401	471348L01	1				
13	OPERATION LABEL - VALVE	F136,F136-C301,F150	485272L01	1				
	操作标签-阀门	F136-C101 F150-C101,F150-C401	486448L01	1				

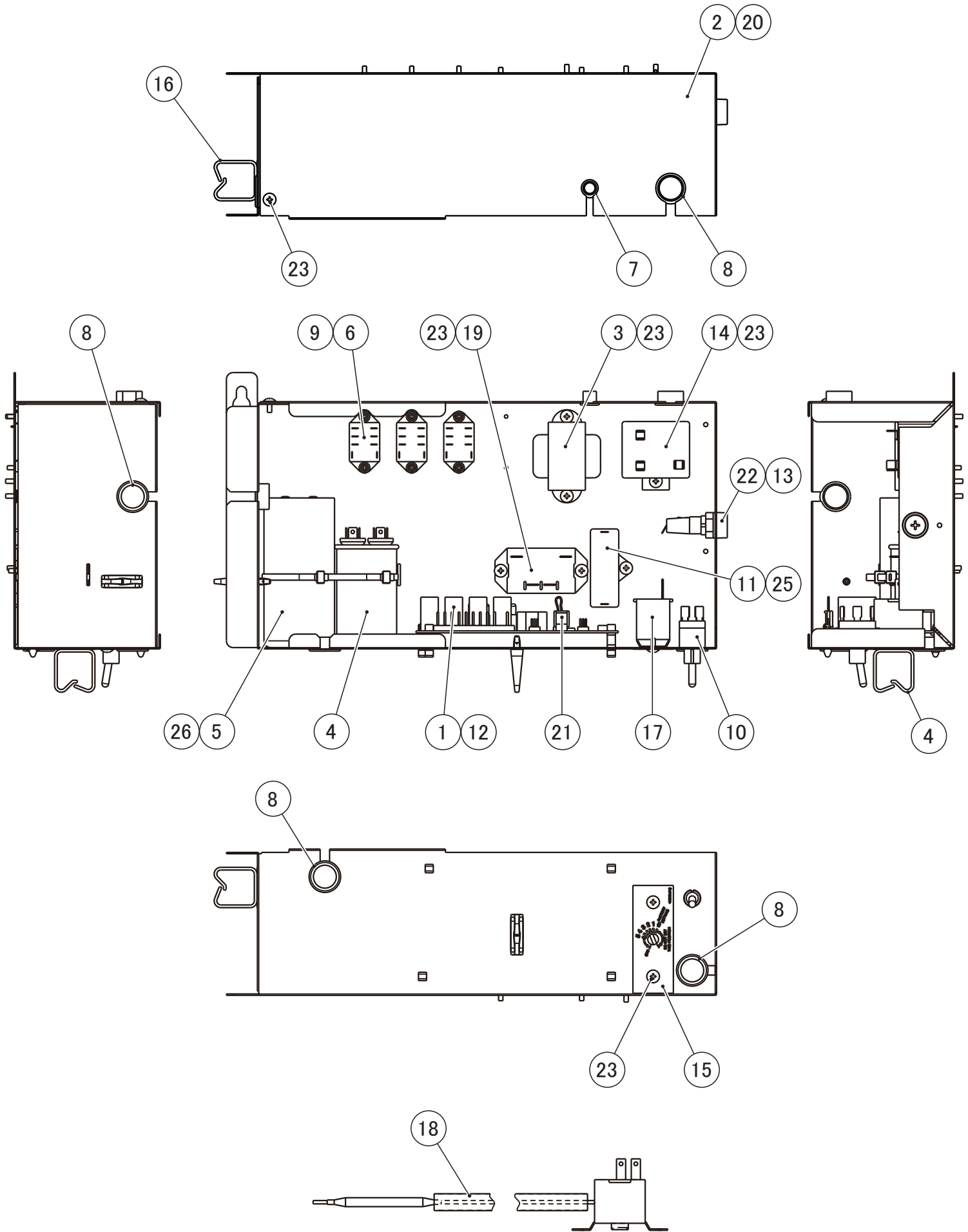

型号/MODEL: **KM-470AJ**

标题/TITLE: **F. CONTROL BOX AY**
控制盒组件

序号 INDEX NO.	部品名称 DESCRIPTION	材质或型号MATERIAL OR MODEL NUMBER	部品序号 PART NUMBER	需求数量 REQ'D NUMBER				
				J-1 and later				
1	CONTROL BOARD J 控制板J		2A7664-04	1				
2	CONTROL BOX (A) 控制盒 (A)		277607M01	1				
3	POWER TRANSFORMER 电源变压器		3A0172-01	1				
4	CAPACITOR-RUN 电容-运行		3A2005-03	1				
5	CAPACITOR-START 电容-启动	F136,F150 F136-C101,F50-C101	3A4788-01	1				
		F136-C301,F150-C401	3A0076-11	1				
6	RELAY 继电器		406132-07	3				
7	BUSHING 衬套		428394-02	1				
8	BUSHING 衬套		428394-04	4				
9	T2(S) FLANGED PAN HEAD SCREW T2 (S) 法兰盘头螺丝		431415-01	6				
10	TOGGLE SWITCH 拨动开关		P01206-01	1				
11	CAPACITOR 电容		P05273-01	1				
12	BOARD SUPPORT 主板支撑		P01770-01	4				
13	FUSE 保险丝		P01432-01	1				
14	STARTER 启动器	F136,F150 F136-C101,F50-C101	4A1107-09	1				
		F136-C301,F150-C401	4A1107-13	1				
15	CONTROL LABEL 控制标签	F136,F136-C301 F150,F150-C401	485335L01	1				
		F136-C101,F150-C101	486453L01	1				
16	CLAMP 夹子		P05316-01	2				
17	THERMOSTAT 调温器		4A2879-02	1				
18	INSULATION TUBE 绝缘套管		277616Z01	1				
19	POWER RELAY 电源继电器		449000-01	1				

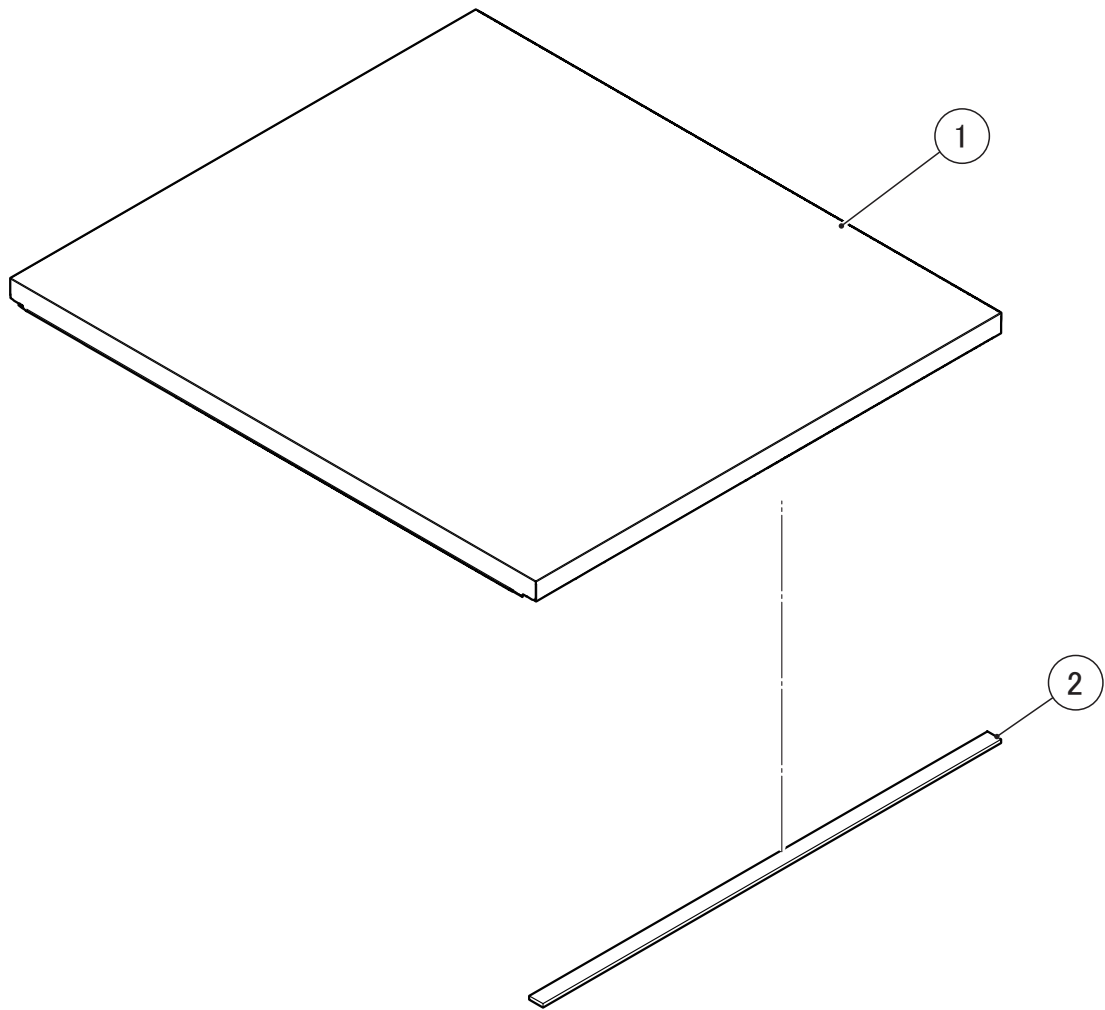

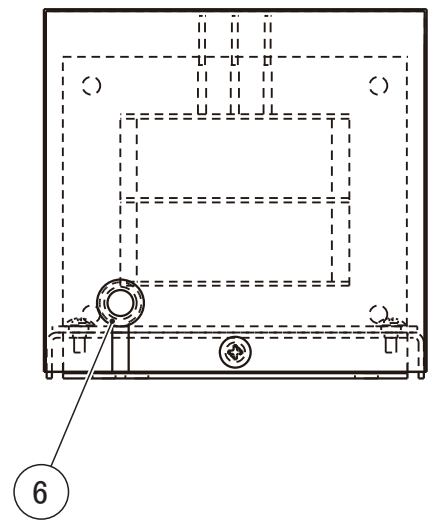
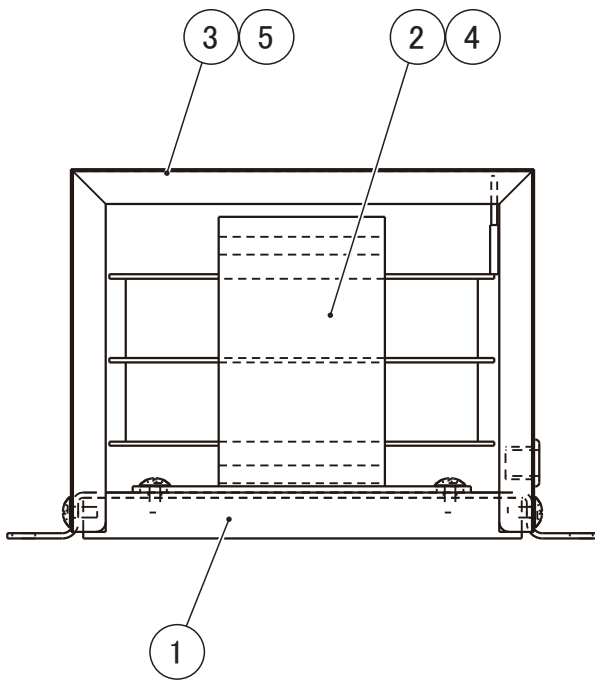
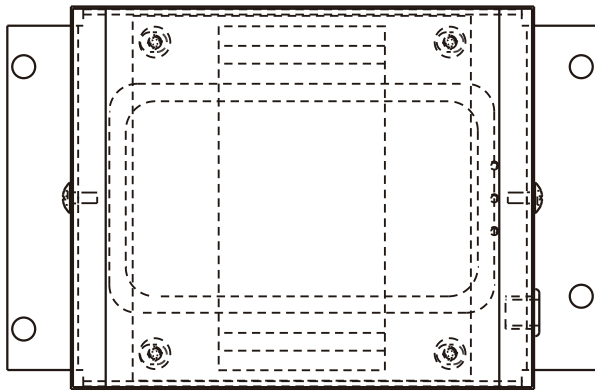

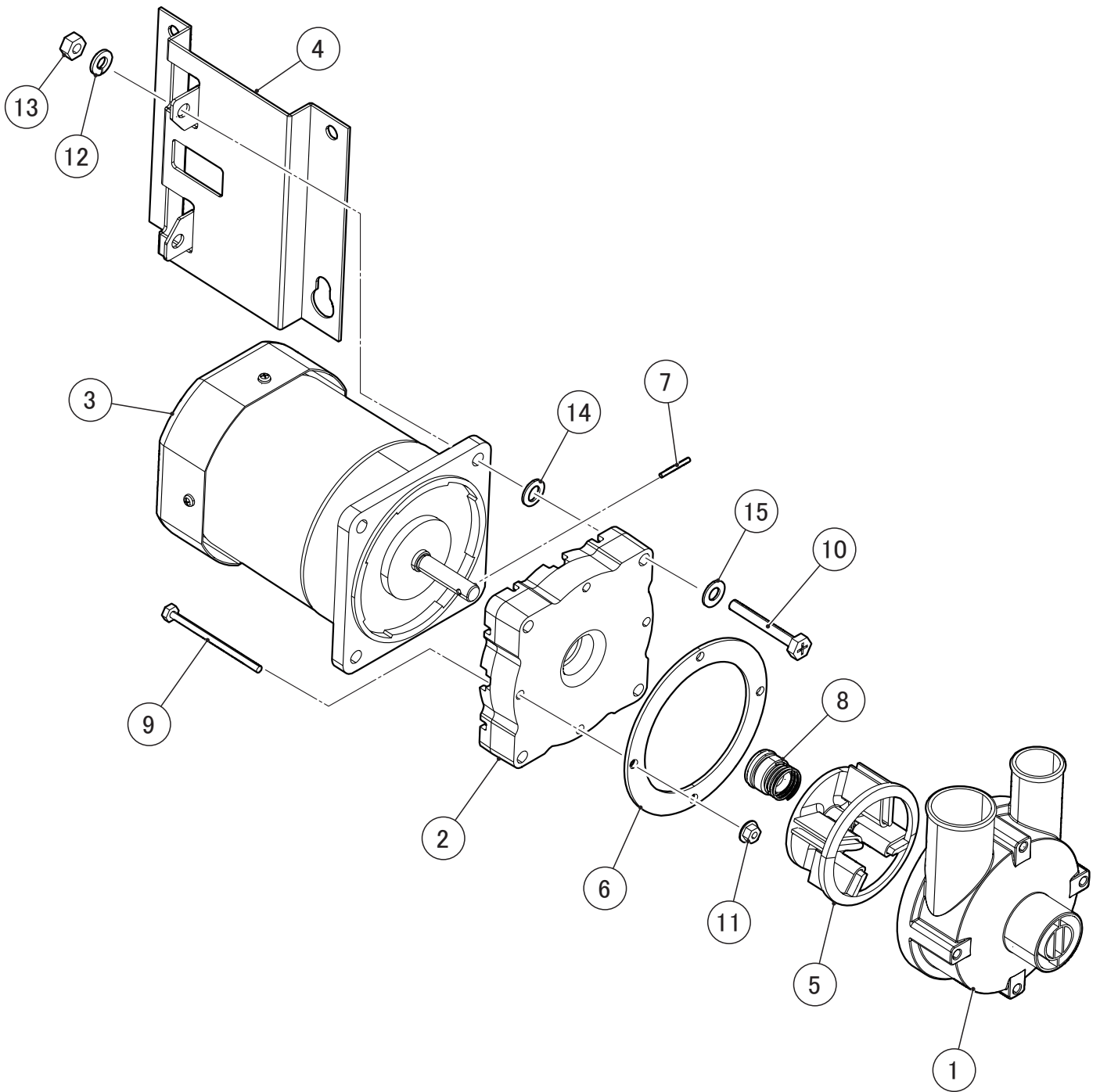

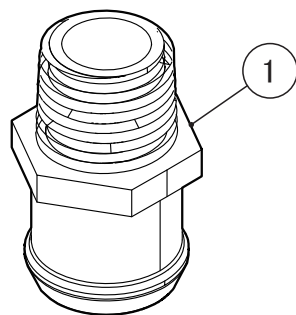
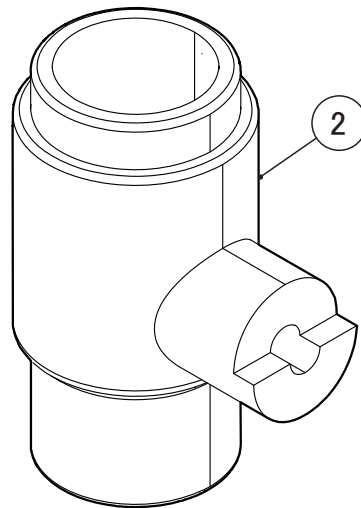
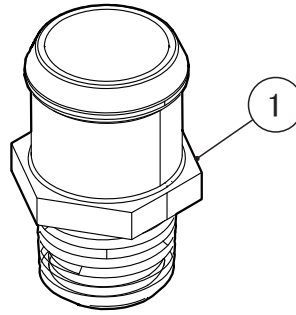

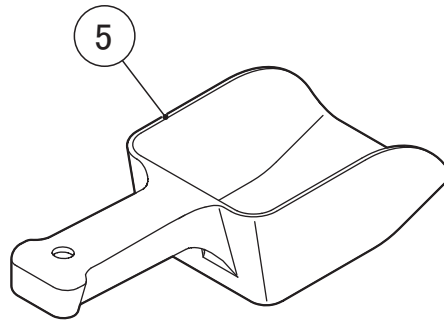
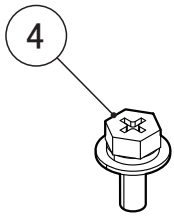
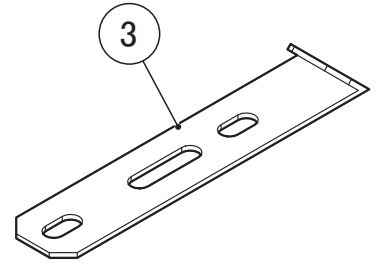
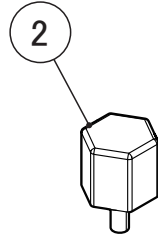
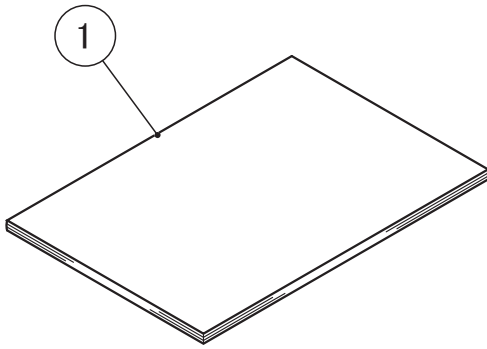

型号/MODEL: **KM-470AJ**

标题/TITLE: **L. ACCESSORIES**
附件

序号 INDEX NO.	部品名称 DESCRIPTION	材质或型号 MATERIAL OR MODEL NUMBER	部品序号 PART NUMBER	需求数量 REQ'D NUMBER				
				J-1 and later				
1	INSTRUCTION MANUAL	F136,F136-C301,F150	L1F136102	1				
	说明书	F136-C101,F150-C101	L1F136301	1				
		F150-C401	L1F136311	1				
2	THUMBSCREW 指旋螺丝		415949G10	2				
3	UNIVERSAL BRACE 通用支撑架		473048M01	2				
4	HEX HEAD BOLT (SPRING WASHER AND FLAT WASHER) 六角螺栓(弹簧垫圈和平垫圈)		FBK0512S0	2				
5	SCOOP 冰铲	F150-C401	1H4123P02	1				