

- KD-0420A
- KY-0420A
- KD-0420W
- KY-0420W



K-0420 Ice Kube Machine



- Easy access to food zone with removal of two screws and lift-off door
- High-tech exterior with smudge and fingerprint resistant stainless-like finish
- White plastics in the food zone help identify areas needing cleaning
- Water shield, distribution tube, pump, floats, and trough removable by hand
- Available CleanAir™ pack controls the growth of bacteria and fungi that form slime and cause odors in the food zone

WARRANTY:

Ice Maker: 3 year Parts & Labor
 Evaporator: 5 year Parts & Labor
 Compressor: 5 year Parts & 3 year Labor



HALF KUBE

$\frac{3}{8}'' \times 1\frac{1}{8}'' \times \frac{7}{8}''$
 (.95 x 2.86 x 2.22 cm)

= 100%



KUBE

$\frac{7}{8}'' \times \frac{7}{8}'' \times \frac{7}{8}''$
 (2.22 x 2.22 x 2.22 cm)

= 100%



K-0420
ICE KUBE MACHINE

Koolaire K-0420 Ice Kube Machine on a K420 bin.











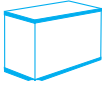



KOOLAIRE®

by **Manitowoc**









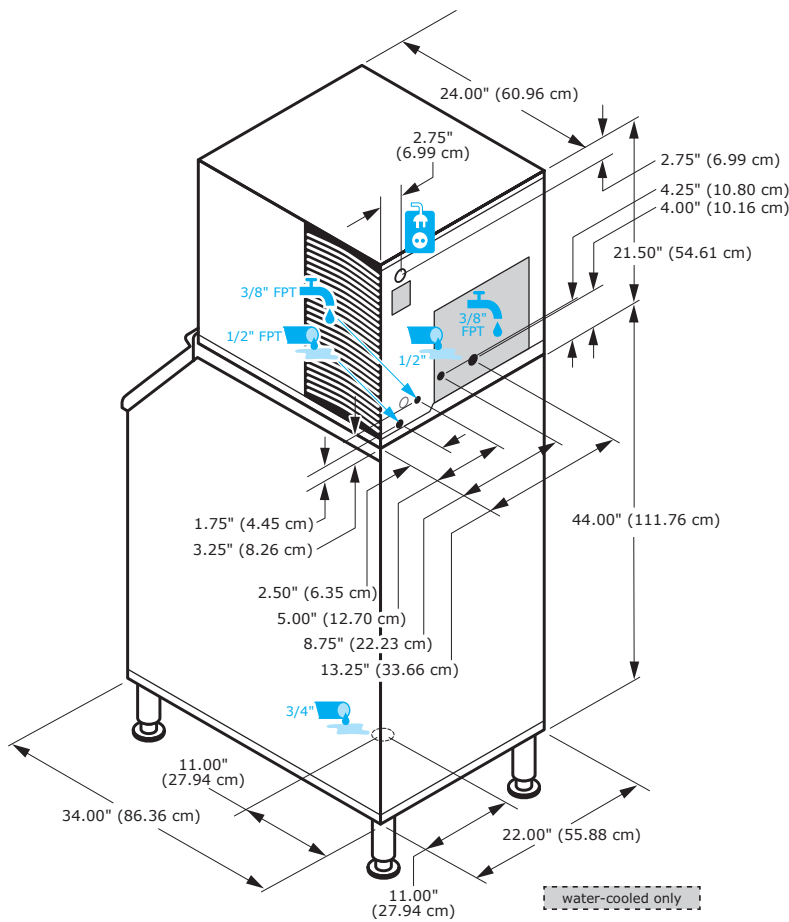



2110 SOUTH 26TH ST | MANITOWOC, WI 54220 USA | 1-920-682-0161 [www.kool-aire.com]



K-0420 ICE KUBE MACHINE

								
				70°/50°F 21°/10°C	90°/70°F 32°/21°C	[kWh/ 100 lbs ice]	[gal/100 lbs ice]	
KD-0420A			370 lbs	305 lbs	6.8	20	•	
			168 kg	138 kg				
KY-0420A			375 lbs	310 lbs	6.8	20	•	
			170 kg	141 kg				
KD-0420W			368 lbs	302 lbs	6.1	20		
			167 kg	137 kg				
KY-0420W			377 lbs	302 lbs	6.1	20		
			171 kg	137 kg				



		
Minimum		Maximum
35°F 1.7°C		110°F 43.3°C
35°F 1.7°C		90°F 32.2°C
20psi 138 kPa		80psi 551 kPa
 10.3	A	
 9.6		
		15 Amps
 136 lbs  132 lbs	62 kg 60 kg	

Water cooled condenser water usage /100lbs. or 45.4kg. of ice: 170 gals. /644L.

Popular Accessories			
Artic Pure Water Filters AR-Pre & AR 10000	Dispenser Bin Thermostat Kit K-00457	Top Air Discharge Kit K-00438	Clean Air Pack K-00206

KOOLAIRE®
by **Manitowoc**

2110 SOUTH 26TH ST | MANITOWOC, WI 54220 USA | 1-920-682-0161 [www.kool-aire.com]