

Indigo™ Series 850 Ice Cube Machine

Model: IR-0850A ID-0852A IY-0854A IR-0851W ID-0853W IY-0855W
 IR-0890N ID-0892N IY-0894N



Indigo Series i-850
Ice Machine on B-570 Bin

Designed for operators who know that ice is critical to their business, the Indigo™ Series ice machine's preventative diagnostics continually monitor itself for reliable ice production. Improvements in cleanability and programmability make your ice machine easy to own and less expensive to operate.

- **Space-Saving Design** – Up to 940 lbs. (426 kgs.) daily ice production and only 30" (76.20 cm) wide.
- **Intelligent Diagnostics** – provide 24 hour preventative maintenance and diagnostic feedback for trouble free operation.
- **Acoustical Ice Sensing Probe** – for reliable operation in challenging water conditions.
- **EasyRead Display** – communicates operating status, cleaning reminders, and asset information through a blue illuminated display.
- **Programmable Ice Production** – by On/Off Time, Ice Volume or Bin Level (with accessory bin level control) further improves energy efficiency and savings.
- **Easy to Clean Foodzone** – Hinged front door swings out for easy access. Removable water-trough, distribution tube, curtain, and sensing probes for fast and efficient cleaning. Select components made with AlphaSan® antimicrobial.
- **DuraTech™ Exterior** – provides superior corrosion resistance. Stainless finish with innovative clear-coat resists fingerprints and dirt.
- Available **LuminIce™ Growth Inhibitor** controls the growth of bacteria and yeast within the foodzone.

Specifications

BTU Per Hour:

13,000 (average)
16,000 (peak)

Refrigerant:

R-404A CFC-free

Operating Limits:

Ambient Temperature Range:
35° to 110°F (1.7° to 43.3°C)
Water Temperature Range:
35° to 90°F (1.7° to 32.2°C)
Water Pressure Ice Maker Water In:
Min. 20 psi (137.9 kPa)
Max. 80 psi (551.1 kPa)

Ice Machine Electric

208-230/60/1
(208-230/60/3 and 230/50/1 also available)

Minimum circuit ampacity:

Air-cooled: 11.9 1ph 9.2 3ph
Water-cooled: 10.9 1ph 8.2 3ph
Remote: 11.9 1ph 9.2 3ph

Maximum fuse size:

Air-cooled: 20 1ph 15 3ph
Water-cooled: 20 1ph 15 3ph
Remote: 20 1ph 15 3ph

Ice Shape



Half Dice
3/8" x 1 1/8" x 7/8"
(.95 x 2.86 x 2.22 cm)



Dice
7/8" x 7/8" x 7/8"
(2.22 x 2.22 x 2.22 cm)



Regular
1 1/8" x 1 1/8" x 7/8"
(2.86 x 2.86 x 2.22 cm)



COMPANY WITH
QUALITY SYSTEM





i-850 on B-570 Storage Bin

- (A) Electrical Entrance (2) Options
- (B) 3/8" (0.95 cm) F.P.T. Water Condenser Inlet (water-cooled units)
- (C) 1/2" (1.27 cm) F.P.T. Water Condenser Outlet (water-cooled units)
- (D) 1/2" (1.27 cm) Auxillary Base Drain Socket
- (E) 3/8" (0.95 cm) F.P.T. Ice Making Water Inlet
- (F) 1/2" (1.27 cm) F.P.T. Ice Making Water Drain
- (G) 3/4" (1.91 cm) Bin Drain

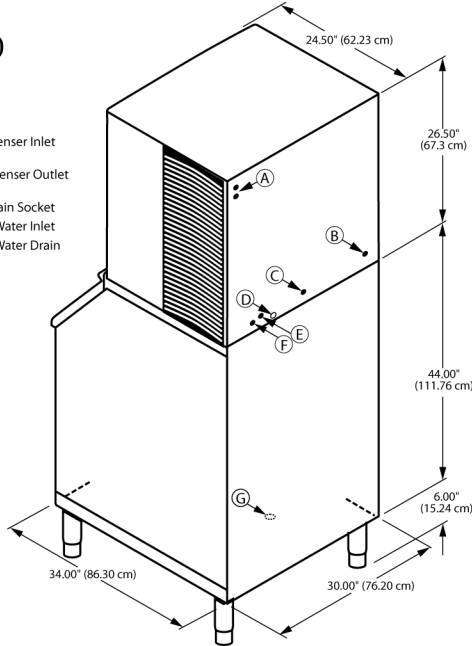

Installation Note
 Minimum installation clearance:
 Top/sides: 8" (20.32 cm);
 Back is 5" (12.7 cm)

Space-Saving Designs



	i-850 B-570	i-850 B-970*
Height	76.50" 194.30 cm	76.50" 194.30 cm
Width	30.00" 76.20 cm	48.00" 121.92 cm
Depth	34.00" 86.30 cm	34.00" 86.30 cm
Bin Storage	430 lbs. 195 kgs.	710 lbs. 322.2 kgs.

Height includes adjustable bin legs 6.00" to 8.00", (15.24 to 20.32 cm) set at 6.00" (15.24 cm).

*For comparison purposes multiply ARI capacity by 1.3 (30%) to arrive at approximate "Application Rating Capacity."

Specifications

	Model	Ice Shape	Ice Production 24 Hours				Power Usage kWh/100 lbs.@90°Air/70°F		Water Usage/100 lbs. 45.4 kgs. of Ice		ENERGY STAR [®]
			70°Air/ 50°F Water	90°Air/ 70°F Water	1 Ph	3 Ph	Potable Water				
AIR-COOLED	IR-0850A	regular	820 lbs.	372 kgs.	615 lbs.	279 kgs.	5.84	5.84	20 Gal.	75.7 L	
	ID-0852A	dice	785 lbs.	356 kgs.	575 lbs.	261 kgs.	6.25	6.25	20 Gal.	75.7 L	
	IY-0854A	half-dice	940 lbs.	426 kgs.	650 lbs.	295 kgs.	5.54	5.54	20 Gal.	75.7 L	
WATER-COOLED	IR-0851W	regular	814 lbs.	369 kgs.	670 lbs.	304 kgs.	4.80	4.80	20 Gal.	75.7 L	NA
	ID-0853W	dice	835 lbs.	379 kgs.	640 lbs.	290 kgs.	4.87	4.87	20 Gal.	75.7 L	NA
	IY-0855W	half-dice	875 lbs.	397 kgs.	730 lbs.	331 kgs.	4.52	4.52	20 Gal.	75.7 L	NA
* Water-cooled Condenser Water Usage / 100 lbs. /45.4 kgs. Of Ice: 150 gal/568 L. * Water-cooled models are excluded from ENERGY STAR qualification.											
REMOTE-COOLED	IR-0890N	regular	735 lbs.	333 kgs.	625 lbs.	283 kgs.	5.91	5.91	20 Gal.	75.7 L	
	ID-0892N	dice	750 lbs.	340 kgs.	610 lbs.	277 kgs.	6.07	6.07	20 Gal.	75.7 L	
	IY-0894N	half-dice	860 lbs.	390 kgs.	645 lbs.	293 kgs.	5.78	5.78	20 Gal.	75.7 L	

Order ice storage bin separately. Ice storage bin and JC-0895 remote condenser must be ordered separately. Consult remote condenser specification sheet for details.
 To order 3 phase add "3" suffix to model # (ID-0852A3).

Accessories

LuminIce™ Growth Inhibitor
 reduces yeast and bacteria growth for a cleaner ice machine.



Bin Level Control
 Allows ice bin level to be automatically set. Built-in LED light illuminates bin.



Arctic Pure® Water Filters
 Reduces sediment and chlorine odors for better tasting ice.



AuCS®
 schedules and performs routine ice machine cleaning automatically.

