



Ice Machine Parts List for Series S1000 Models

SD1002A

SY1004A

SD1003W

SY1005W

SD1092N

SY1094N

S1000 CONTROL BOX

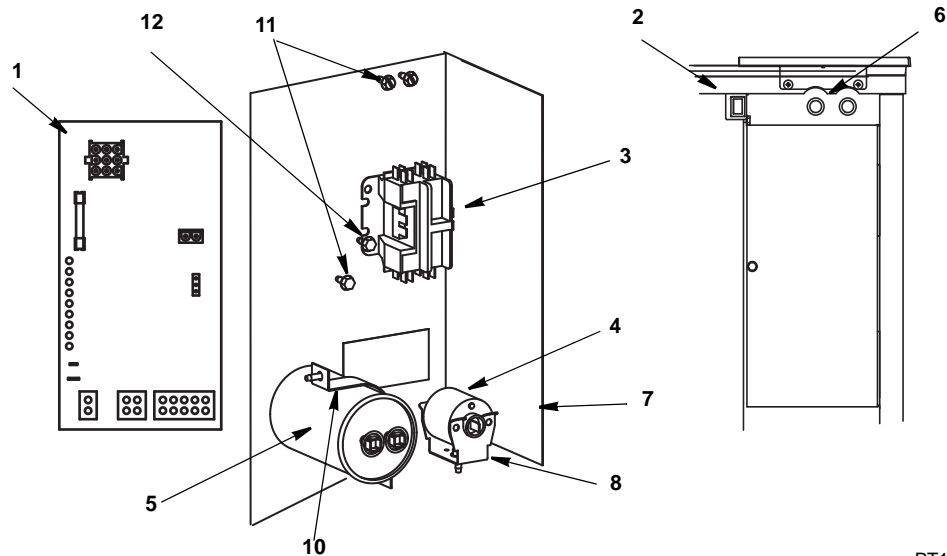

PT1388

DESCRIPTION

	PART NO.
1 Control Board (for use with all voltages)	20-0619-9
a. 7 Amp Fuse – Mounted on Control Board	000008240
2 Toggle Switch Only	20-0793-9
a. Toggle Switch Wiring Harness	20-0807-9
b. Toggle Switch Box	40-1163-9
3 Contactor	
a. 208-230V/60 Hz/1 Ph or 230V/50 Hz 1Ph.	20-0659-9
b. 208-230V/60 Hz/3 Ph	20-0661-9
4 P.T.C.R. Compressor Starter.	85-0499-3
5 Compressor Run Capacitor (208-230V/50/60 Hz/1 Ph)	20-1013-3
6 Refrigeration Service Valve Assembly	83-7326-3

Miscellaneous – Brackets, Screws, etc.

7 Control Box	76-0214-3
a. Control Box Cover (Not shown).	76-0215-3
8 P.T.C.R. Compressor Starter Mounting Bracket	85-0501-3
9 Control Board Mounting Supports (Not shown)	43-0225-3
10 Capacitor Mounting Strap	602495-3
11 Screw, #10-24 x .50 Ground	52-0216-9
a. Star Washer	55-7320-9
12 Screw, #10-24 x .50	52-0206-9
13 Control Box Wiring Harness (Not shown)	
a. 230/60/1.	20-0734-9
b. 230/60/3.	20-0736-9
c. 230/50/1.	20-0735-9
d. Harvest Air Assist Pump	20-0743-9

S1000 EVAPORATOR COMPARTMENT

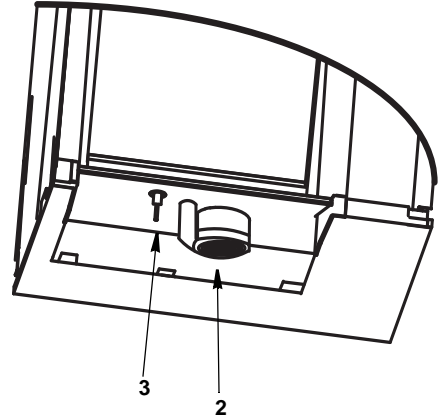
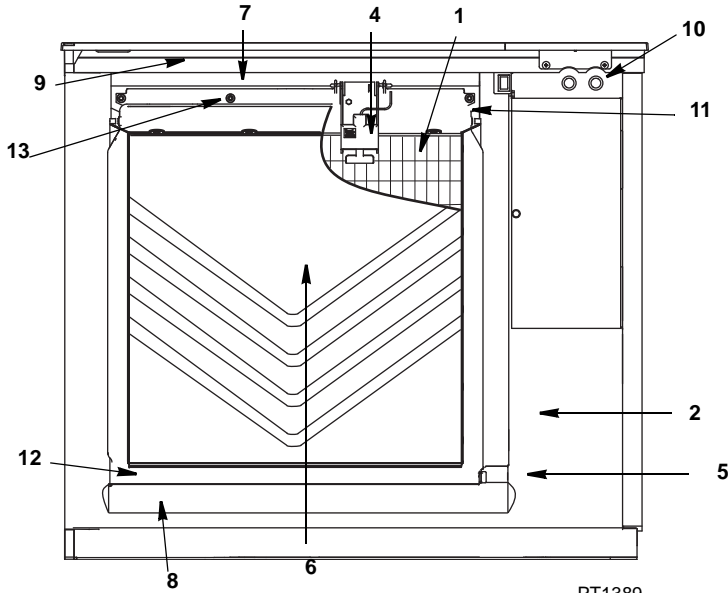

DESCRIPTION

		PART NO.
1	Evaporator Assembly	
	a. Dice Cube	76-0228-3
	b. Half Dice Cube	76-0227-3
2	Water Pump	
	a. 230V/60 Hz 1/3PH	82-5113-9
	b. 230/50/1	82-5270-9
3	Water Level Probe	
	a. Wire, control box to probe	20-0654-9
4	Ice Thickness Control Probe	20-0798-9
5	Magnetic Bin Switch	20-0802-9
6	Water Curtain	000007888
7	Water Distribution Tube Assembly	
	a. O-Rings (Back of Distribution Assembly)	40-1098-9
8	Water Trough	76-0219-3
9	Evaporator Top Filler Panel	
	a. Stainless Steel Clamp	50-0464-9
	b. Clamp Screw	40-0360-9
10	Access Valve	40-0846-9
11	Evaporator Top Frame Assembly	
	a. Thumbscrew	606333-9
12	Water Diverter	52-0209-9
	a. Thumbscrew	83-7326-3
	b. Clamp Screw	76-0220-3
	c. Thumbscrew	76-0221-3
	d. Clamp Screw	53-0512-3
	Miscellaneous – Brackets, Screws, etc.	
13	Screw, (Water Distribution Tube Mounting) Each	50-0479-9
	a. O-Ring	50-0462-9
14	Screw, #12-16 x .687 Used to Mount Evaporator (Each)	50-0461-9
15	Water Pump Base O-Ring	50-0465-9
16	Water Pump Outlet O-Ring	50-0467-9
17	Vinyl Tubing 0.625 ID (dump valve to drain adapter)	000001382
	a. Insulation	603883-1

S1000 REFRIGERATION COMPARTMENT – COMMON PARTS

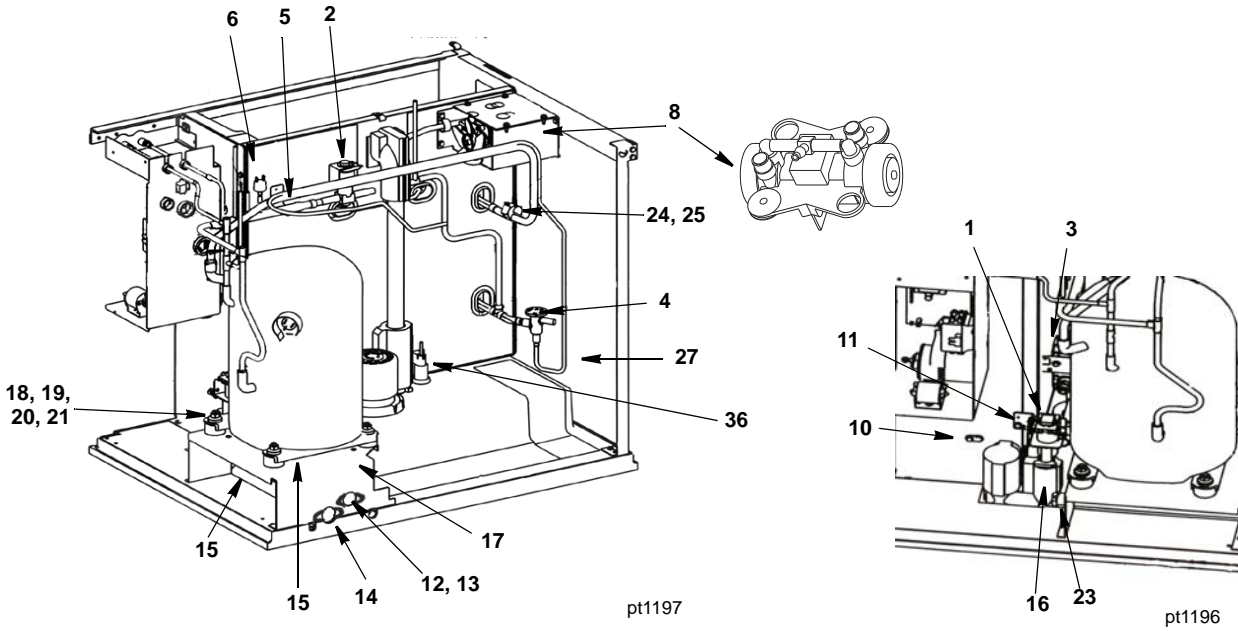

DESCRIPTION

PART NO.

1 Water Dump Valve	
a. Dump Valve, 208-230V/50-60 Hz	000001768
b. Dump Valve Rebuild Kit	No Longer Available
2 Harvest Valve	
a. Harvest Valve Including 208/230V 50/60 Hz Electrical Coil	76-3012-1
b. Harvest Valve 208/230V 50/60 Hz Coil Only Alco	† 24-0448-3
c. Harvest Valve 208/230V Coil Only Danfoss	000005157
3 Water Inlet Valve	
a. Water Inlet Valve Including 208-230V/50-60 Hz Coil	000007966
4 Expansion Valve	76-0225-3
a. Expansion Valve Body Insulation Boot	40-0036-3
b. Expansion Valve Bulb Insulation Boot	40-0720-3
5 Manifold Strainer (in front of hot gas valve)	82-5104-9
6 High Pressure Cut-out (Auto Reset)	20-0124-3
7 Electrical Box on Rear of Ice Machine	
a. Box	Included in Back Panel Assembly
b. Terminal Block 3 Pole	20-0614-3
c. Groundscrew #10-24 x .50	52-0216-9
8 Air Pump	
a. Air Pump 230V with brackets	76-0353-9
b. Manifold Tee (Air Pump Tubing Outlet)	40-1173-9
9 Compressor Compartment Wiring Harness	
After Serial Number 110697023	
a. Air	000002327
b. Water	000002328
c. Remote	000002329
Before Serial Number 110697023	
a. Water	20-0732-9
b. Air	20-0731-9
c. Remote	20-0733-9
10 Bin Switch	000007888

† Refer to Cross Reference Guide

Miscellaneous – Brackets, Screws, etc.

11	Dump Valve Mounting Bracket	605845-9
12	Water Inlet Valve Wing Adapter	87-0609-3
13	Water Inlet Valve Wing Adapter Plastic Fitting	13-6096-1
14	Water Drain Female Wing Adapter	87-0608-3
15	Water Drain Clear Tubing, .625 ID x 12 inches	44-2038-3
16	Dump Valve Tubing 3.25 inches.	44-2038-3
17	Compressor Mounting Base.	606170-9
18	Compressor Mounting Rubber Grommet. †	85-0306-9
19	Compressor Mounting Sleeve	85-0394-9
20	Compressor Mounting Bolt.	50-0481-9
21	Compressor Mounting Nut	50-0482-9
22	Compressor Wiring Harness	20-0623-9
23	Clamp, Water Drain	56-5070-9
24	Clamp, Expansion Valve Bulb	56-5052-9
25	Copper Bulb Strap	30-0050-3
26	Screw, #10-24 x .50	52-0206-9
27	Left Corner Post	606865-9
28	Left Top Channel	606864-9
29	Right Corner Post.	000008752
30	Right Top Channel	606257-9
31	Insulated Tube (vinyl tubing from distribution tube to water pump & dump valve).	000003406
	a. Clamp .859/.989 ID	56-5060-3
	b. Clamp .799/.899 ID	56-5070-3
32	Water Inlet Valve Tubing	40-1043-9
33	Connector Water Inlet Valve.	13-6098-9
34	Water Inlet Valve Bracket.	605845-9
35	Check Valve Replacement (includes water diverter, vinyl tubing & insulation)	000002473
36	Holder, Water Level Probe	20-0655-9
37	Screw to Mount Water Level Probe Holder	52-0209-9

† Refer to Cross Reference Guide

S1000 REFRIGERATION COMPARTMENT – AIR-COOLED

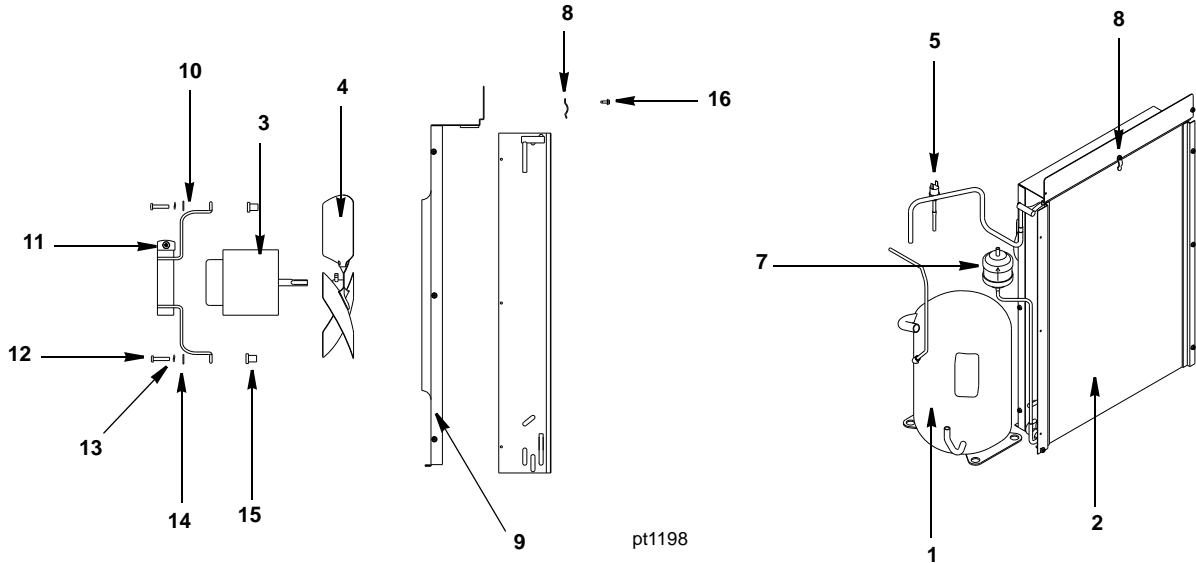

pt1198

pt1199

DESCRIPTION

PART NO.

NOTE: Copeland compressors must be replaced with Copeland compressors and Bristol compressors must be replaced with Bristol compressors.

1 Compressor - Copeland	
a. 208-230V/60 Hz/1 Ph	76-0229-3
b. 208-230V/60 Hz/3 Ph	76-0230-3
c. 230V/50 Hz/1 Ph	76-0231-3
1 Compressor - Bristol	
a. 208-230V/60 Hz/1 Ph	000008726
b. 208-230V/60 Hz/3 Ph	000008727
c. 230V/50 Hz/1 Ph	000008728
2 Air Condenser	82-5239-9
3 Fan Motor (208-230V/60 Hz or 230V/50 Hz)	76-2672-3
4 Fan Blade	24-1612-3
5 Fan Cycling Control	† 20-0127-3
6 Air Filter (Not shown)	30-0555-9
7 Drier	89-3025-9
Miscellaneous – Brackets, Screws, etc.	
8 Air Filter Clip	† 56-5069-9
9 Fan Shroud	605811-9
10 Fan Motor Mounting Bracket	30-0684-3
11 Fan Motor Mounting Screw	† 50-3358-9
a. Fan Motor Mounting Lockwasher	† 55-4510-9
b. Fan Motor Mounting Hexnut	† 54-2952-9
12 Fan Bracket Mounting Screw	50-3238-9
13 Fan Bracket Mounting Lockwasher	† 55-4510-9
14 Fan Bracket Mounting Flatwasher	† 55-7305-9
15 Fan Bracket Mounting Rubber Wellnut	† 54-2955-9
16 Screw, #10-24 x .50	† 52-0206-9

† Refer to Cross Reference Guide

S1000 REFRIGERATION COMPARTMENT – WATER-COOLED

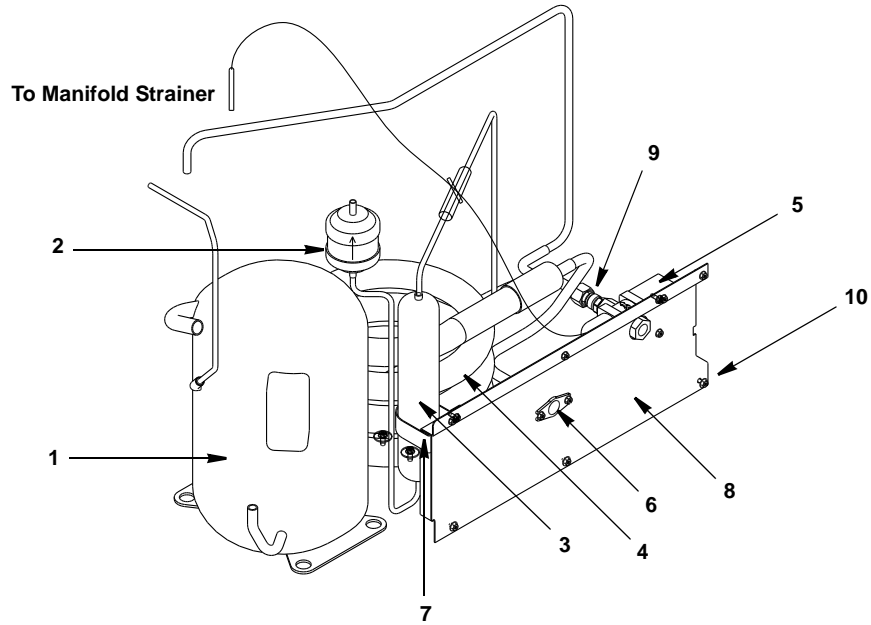

pt1200

DESCRIPTION

PART NO.

NOTE: Copeland compressors must be replaced with Copeland compressors and Bristol compressors must be replaced with Bristol compressors.

1 Compressor - Copeland	
a. 208-230V/60 Hz/1 Ph	76-0229-3
b. 208-230V/60 Hz/3 Ph	76-0230-3
c. 230V/50 Hz/1 Ph	76-0231-3
1 Compressor - Bristol	
a. 208-230V/60 Hz/1 Ph	000008726
b. 208-230V/60 Hz/3 Ph	000008727
c. 230V/50 Hz/1 Ph	000008728
2 Drier	89-3025-9
3 Receiver	89-0012-3
4 Water-cooled Condenser	† 000001507
5 Water Regulating Valve	83-7206-9
6 Water Drain Female Wing Adapter	87-0608-3
Miscellaneous – Brackets, Screws, etc.	
7 Receiver Strap	600054-1
8 Back Panel	606173-9
9 Elbow .50 MF x .375 MPT	50-0224-9
10 Screw, #10-24 x .50	52-0206-3
11 Washer	55-7341-9
12 Base, Water Condenser/Receiver	605865-9

† Refer to Cross Reference Guide

S1000 REFRIGERATION COMPARTMENT – REMOTE

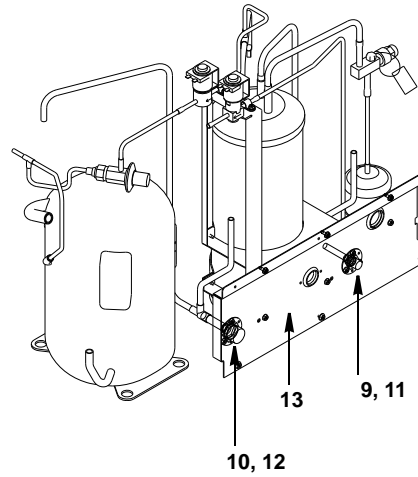
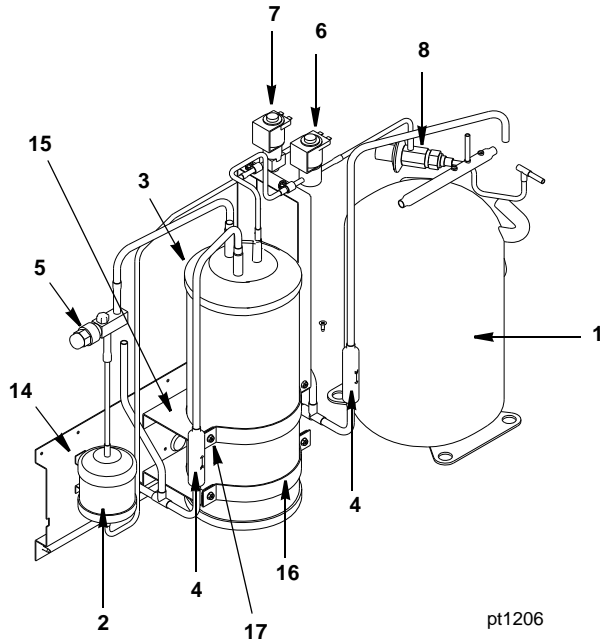

DESCRIPTION

PART NO.

NOTE: Copeland compressors must be replaced with Copeland compressors and Bristol compressors must be replaced with Bristol compressors.

1 Compressor - Copeland	
a. 208-230V/60 Hz/1 Ph	76-0229-3
b. 208-230V/60 Hz/3 Ph	76-0230-3
c. 230V/50 Hz/1 Ph	76-0231-3
1 Compressor - Bristol	
a. 208-230V/60 Hz/1 Ph	000008726
b. 208-230V/60 Hz/3 Ph	000008727
c. 230V/50 Hz/1 Ph	000008728
2 Drier	89-3027-9
3 Receiver	76-2957-3
4 Magni-Check Valve	† 83-7314-9
5 Refrigeration Service Valve	† 83-7316-9
a. Cap for Refrigeration Service Valve	56-5075-9
6 Harvest Pressure Regulating Solenoid (HPR) Valve	
a. HPR Valve Including 208/230V 50/60 Hz Electrical Coil (Danfoss)	† 76-3006-1
b. HPR Valve 208/230V 50/60 Hz Coil Only Danfoss	000005157
7 Liquid Line Solenoid (LLS) Valve	
a. LLS Valve Including 208/230V 50/60 Hz Electrical Coil (Danfoss)	† 76-3008-1
b. LLS Valve 208/230V 50/60 Hz Coil Only Danfoss	000005157
8 Harvest Pressure Regulating Valve (HPR)	† 83-6779-3
9 Coupling – Male, 5/8-18	† 83-6034-3
10 Coupling – Male, 1-1/6-12	† 83-6035-3
Miscellaneous – Brackets, Screws, etc.	
11 Coupling Mounting Flange for 5/8-18	83-6005-3
12 Coupling Mounting Flange for 1-1/16-12	83-6006-3
13 Back Panel	606173-9
14 Drier Support Bracket	56-5061-9
15 Receiver Mounting Bracket	600056-1
16 Receiver Mounting Strap	630721-4
17 Screw, #10-24 x .50	† 52-0206-9
18 Base (Receiver Mounting)	605865-9

† Refer to Cross Reference Guide

S1000 PANELS

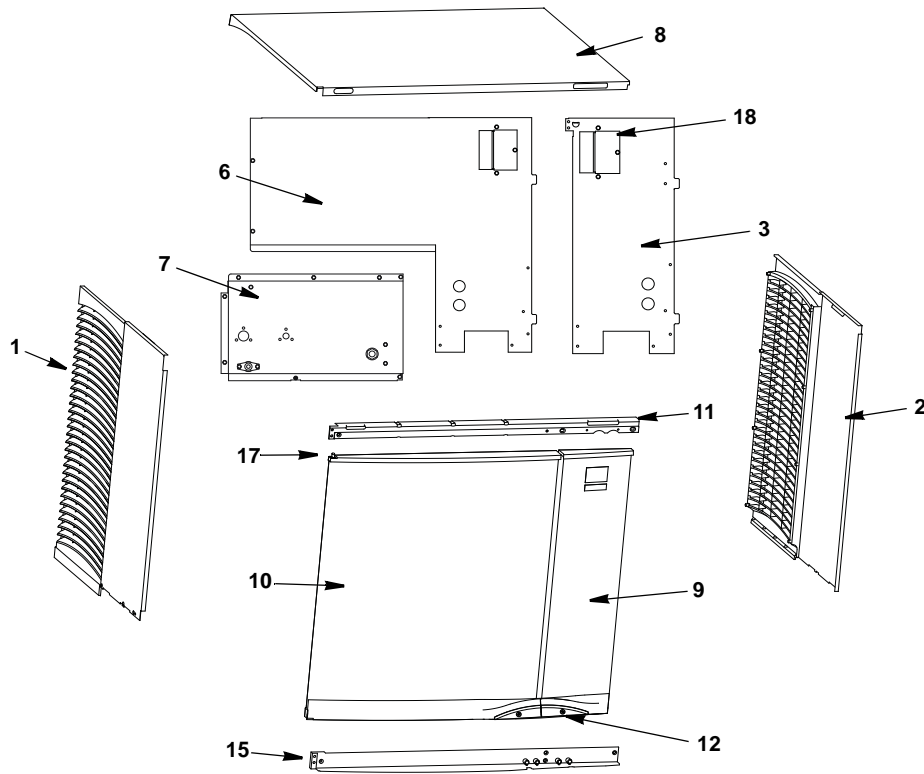

DESCRIPTION

	PART NO.
1 Left Side Panel	606055-9
2 Right Side Panel	606054-9
Air-Cooled Back Panels)	
3 Back Panel with Electrical Connection Box, Air-cooled Models	606169-9
4 Air Filter (Not Shown)	30-0555-9
5 Air Baffle (Not Shown)	605971-9
Water-Cooled & Remote Air-Cooled Back Panels)	
6 Back Panel with Electrical Connection Box,	605864-9
7 Back Coupling Panel, Water Connections	606173-9
Aluminum Front Top Support on machine (replace all)	
8 Top Cover	000006699
9 Right Door	607122-1
10 Left Door	607121-1
11 Front Top Support	000000295
Mounting Screw Left Side 8-32 x 1	50-0537-9
Mounting Screw Right Side 10-24 x.50	50-0509-9
Plastic Front Top Support on machine (replace as needed)	
8 Top Cover	000006699
9 Right Door	607122-1
10 Left Door	607121-1
11 Front Top Support	000000295
Mounting Screw Left Side 8-32 x 1	50-0537-9
Mounting Screw Right Side 10-24 x.50	50-0509-9
Miscellaneous – Brackets, Screws, etc.	
12 Right/Left Door Screw	50-0489-9
13 Left Door Endcaps	
a. Top	40-1511-3
b. Bottom	40-1512-3
14 Right Door Endcaps	
a. Top	40-1514-3
b. Bottom	40-1515-3
15 Bottom Door Frame	76-0226-3
a. Mounting Screw Left Side 8-32 x 1 PHIL	50-0537-9
b. Mounting Screw Right Side 10/24 x .50 PHIL	52-0209-9
16 Door Catch Bracket (RHD)	606236-9
a. Mounting Screw 8-32 x .50 Phil	50-2624-9
17 Left Door Pivot Leaf Hinge (Top or Bottom)	30-0557-9
a. Mounting Screw 8-32 x 1 PHIL	50-0537-9
18 Electrical Connection Box Cover	Included in Back Panel Assembly
19 Sachet Holder (inside left door)	40-0459-9
a. Screws	50-0479-9

JC895 REMOTE CONDENSER

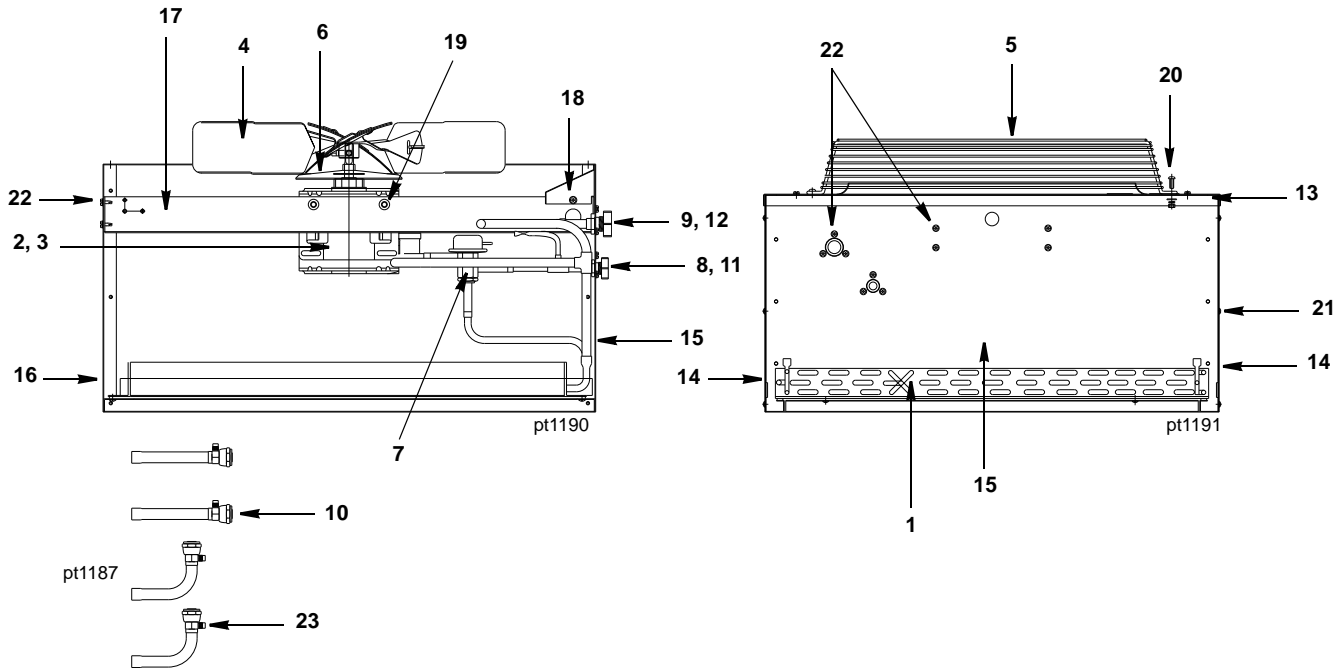

DESCRIPTION

	PART NO.
1 Air Condenser	† 88-5062-9
2 Fan Motor (208-230V 50/60 Hz/1 Ph)	† 76-2941-3
3 Fan Motor Run Capacitor (Emerson)	85-0458-3
3 Fan Motor Run Capacitor (Magnatec)	No Longer Available
4 Fan Blade	24-1611-3
5 Fan Guard	34-0064-3
6 Rain Slinger	24-1505-3
7 Head Pressure Control	
a. Before Serial Number 110697288	000004070
b. After Serial Number 110697288	000002369
8 Coupling – Male, 5/8-18	† 83-6034-3
9 Coupling – Male, 1-1/6-12	† 83-6035-3
10 Female Line Set Coupling Kit (Sold as Finished Goods Sales Kit)	Sales K0129

Miscellaneous – Brackets, Screws, etc.

11 Coupling Mounting Flange (for 5/8-18)	83-6005-3
12 Coupling Mounting Flange (for 1-1/16-12)	83-6006-3
13 Top Cover	† 601775-1
14 Panel – Side	† 601774-1
15 Panel – Rear	† 601773-1
16 Panel – Front	† 601772-1
17 Fan Motor Mounting Bracket	† 601768-1
18 Electrical Box Cover	† 601776-1
19 Fan Motor Mounting Screw (5/16-18 x 5/8)	† 50-3565-9
a. Fan Motor Mounting Flatwasher	† 55-7309-9
b. Fan Motor Mounting Lockwasher	† 55-7313-9
c. Fan Motor Mounting Hexnut	54-2975-9
20 Fan Guard Mounting Screw (1/4-20 x 5/8)	† 50-3345-9
a. Fan Guard Mounting Flatwasher	† 55-7304-9
b. Fan Guard Mounting Lockwasher	† 55-4511-9
c. Fan Guard Mounting Hexnut	† 54-2952-9
21 Panel/Condenser Mounting Screw (#8 x 1/2)	† 51-2153-9
a. Panel/Condenser Mounting Lockwasher	† 55-4459-9
22 Screw (#10-24 x 1/2)	† 52-0206-9
23 Valve Cores (used in linesets)	76-2684-3
24 Legs (Not shown)	† 601769-1