

# 11 Exploded View and Replacement Parts List

## 11.1. Exploded view and parts list

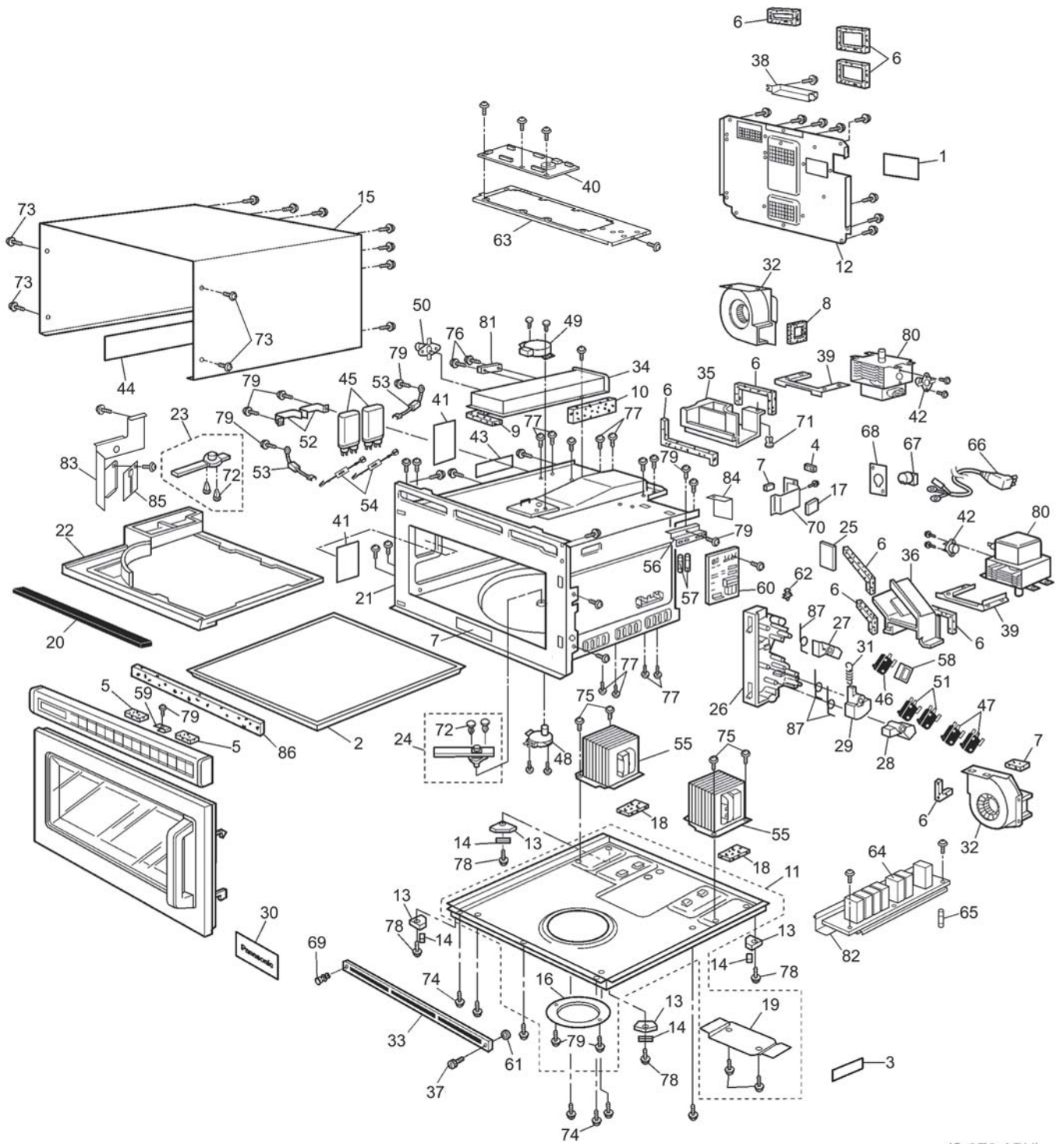

(S-3E8-APH)

# PARTS LIST

NOTE 1: When ordering replacement part(s), please use part number(s) shown in this parts list.

Do not use description of the part.

2: Important safety notice:

Components identified by  $\triangle$  mark have special characteristics important for safety.

When replacing any of these components, use only manufacturer's specified parts.

3: Alphabet marks in Remarks columns (i.e. HNE etc) indicate parts applicable to only specified country models as follows.

**WTK : For Taiwan**

**ZPE : For CIS**

**XPE : For China**

Parts without these marks can be used for all models.

Ref. No.	Safety	Part No.	Part Name & Description	Pcs/set	Remarks
1		A00063310WN	CAUTION LABEL	1	NE-1853WTK
1		A00066000ZP	CAUTION LABEL	1	NE-1753ZPE
1		A00067680XN	CAUTION LABEL	1	NE-1753XPE
2		ANE010T8U0AP	SHELF	1	
3	$\triangle$	A05363F90WT	NAME PLATE	1	NE-1853WTK
3	$\triangle$	A00073F80ZP	NAME PLATE	1	NE-1753ZPE
3	$\triangle$	A00073F80XP	NAME PLATE	1	NE-1753XPE
4		ANE0901000CD	CUSHION RUBBER A	1	
5		ANE000Z000AD	CUSHION RUBBER C	5	
6		ANE000Z000AA	CUSHION RUBBER C	10	
7		ANE000Z000AD	CUSHION RUBBER C	4	
8		ANE000Z000AB	CUSHION RUBBER C	1	
9		ANE0962000AV	CUSHION RUBBER D	1	
10		ANE0962000AP	CUSHION RUBBER D	1	
11		A100A-3290	BASE	1	W/FOOT,RUBBER FOOT (NOTE 4)
12		A100Q3E80AP	BACK PANEL	1	
13		A1007-3280	FOOT	4	
14		A1008-3280	RUBBER FOOT	4	
15		A10093E80AP	CABINET BODY	1	
16		ANE10288U0AP	ANTENNA MOTOR COVER	1	
17		ANE10498U0AP	CUSHION RUBBER	1	
18		ANE1062-8U0	CUSHION RUBBER B	3	
19		ANE11668U0AP	BASE METAL	1	
20		ANE11748U0AP	SPACER	1	
21	$\triangle$	A200A3F90EU	OVEN U	1	NE-1753XPE/ZPE
21	$\triangle$	A200A3F90WT	OVEN U	1	NE-1853WTK
22	$\triangle$	A2011-3280S	CEILING PLATE	1	
23		A202K-3850	ANTENNA UPPER (U)	1	
24		A202V3310GP	ANTENNA LOWER (U)	1	NE-1753XPE/ZPE
24		A202V-3850	ANTENNA LOWER (U)	1	NE-1853WTK
25		ANE21208U0AP	SPACER	1	
26	$\triangle$	A3020-3850	DOOR HOOK	1	
27	$\triangle$	A3136-3470	HOOK SPACER A	1	
28	$\triangle$	A3138-3470	HOOK SPACER C	1	
29	$\triangle$	A3137-3850	HOOK SPACER B	1	
30		A31863F90BP	DOOR PANEL	1	NE-1853WTK
30		A31863F80HP	DOOR PANEL	1	NE-1753ZPE/XPE
31		ANE32398U0AP	SPRING	1	
32		A400A3F90EU	FAN MOTOR	2	NE-1753ZPE/XPE
32		A400A3F90WT	FAN MOTOR	2	NE-1853WTK
33		A400B-3280	AIR FILTER FRAME	1	
34		A400K-3180	EXHAUST GUIDE	1	
35		ANE40258U0AP	AIR GUIDE A	1	UPPER
36		ANE40268U0AP	AIR GUIDE B	1	LOWER
37		A4091-3280	SCREW	1	FOR AIR FILTER FLAME
38		A41073980AP	EXHAUST GUIDE B	1	
39		ANE50328U0AP	MAGNETRON BRACKET	2	
40	$\triangle$	A603L3F90WT	D.P.CIRCUIT (U)	1	NE-1853WTK
40	$\triangle$	A603L3F80HP	D.P.CIRCUIT (U)	1	NE-1753ZPE/XPE
41		ANE60408U0AP	OVEN LAMP SHEET	2	
42	$\triangle$	A61454210AP	THERMAL CUTOOUT	2	FOR MAGNETRON
43		ANE60708U0BP	INSULATION SHEET A	1	
44		A60713310BP	INSULATION SHEET B	1	

Ref. No.	Safety	Part No.	Part Name & Description	Pcs/set	Remarks
45	⚠	A63903330GPS	H.V.CAPACITOR	2	
46	⚠	ANE61424L0AG	MICRO SWITCH	1	(V-16G-3C26) PRIMARY LATCH SWITCH
47	⚠	ANE6142-F60	MICRO SWITCH	2	(V-15G-3C26) SECONDARY LATCH SWITCH
48		A6144-3E20	ANTENNA MOTOR	1	(3W) LOWER
49		A6144-3E10	ANTENNA MOTOR	1	(3W) UPPER
50	⚠	A61454050AP	THERMAL CUTOUT	1	FOR OVEN
51	⚠	ANE6161-3X0	MICRO SWITCH	2	(V-16G-1C25) SHORT SWITCH
52		ANE61888U0AP	CAPACITOR BRACKET	2	
53	⚠	A6202-3280	DIODE, SI	2	
54	⚠	A606V3F00APS	PROTECTOR DIODE	2	
55	⚠	A622B3F90EU	H.V. TRANSFORMER	2	NE-1753ZPE/XPE
55	⚠	A622B3F90WT	H.V. TRANSFORMER	2	NE-1853WTK
56		ANE62298U0AP	MOUNTING BRACKET	1	
57	⚠	A62304210BP	FUSE	2	10A
58		A62383230GP	SPACER	1	
59		ANE64086Q0AP	SCREW WASHER	1	
60		A603Y3F90BP	PCB D (U)	1	NE-1853WTK, NE-1753ZPE
60		A603Y3F90MP	PCB D (U)	1	NE-1753XPE
61		A6408-3280	WASHER	1	FOR AIR FILTER FRAME
62		ANE65448U0AP	SPACER A	1	
63		A6585-3B10	P.C.B.HOLDER	1	
64	⚠	A608B3F90BP	PCB M (U)	1	
65		A65953700BP	FUSE B	1	2.5A
66	⚠	A900C3E00WT	AC CORO W/PLUG	1	NE-1853WTK
66	⚠	A900C3F80XP	AC CORO W/PLUG	1	NE-1753XPE
66	⚠	A900C3340EU	AC CORO W/PLUG	1	NE-1753ZPE
67		ANE9027510RN	CORD BUSHING	1	
68		A90353060GP	CORD BRACKET	1	
69		ANE90828U0AP	CLIP (BLACK)	1	FOR AIR FILTER FRAME
70		ANE91448U0AP	BRACKET	1	
71		ANE91628U0AP	CLIP B	1	FOR AIR GUIDE A
72		ANE900T8V0AP	CLIP	4	FOR ANTENNA (U), ANTENNA B (U)
73		XTC4+10BC	SCREW	4	4X10 (FOR CABINET BODY)
74		XTN4+12QJ	SCREW (BLACK)	2	4X12 (FOR BASE)
75		XTEA5+10BJ	SCREW	4	5x10 (FOR H.V. TRANSFORMER)
76		XTWANE3+8EX	SCREW	2	3X8 (FOR TEMP SENSOR)
77		XYEA5+C16TJ	SCREW	8	5X16 (FOR MAGNETRON)
78		XTW3+8BJ	SCREW	4	3X8 (FOR FOOT)
79		XYD4+EE12FJ	SCREW	11	4X12 (FOR DIODE, CAPACITOR BRACKET, SPACER, MOUNTING BRACKET, EARTH, ANTENNA MOTOR COVER, BASE METAL)
80	⚠	2M210-M1J3F	MAGNETRON	2	NE-1753ZPE/XPE
80	⚠	2M210-M1J3FT	MAGNETRON	2	NE-1853WTK
81	⚠	A601L5150AP	TEMP SENSOR	1	
82	⚠	A692R3F90BP	RELAY BRACKET U	1	
83	⚠	A6603-3E10	LAMP BRACKET	1	
84	⚠	A61713A80BP	INSULATION SHEET D	1	
85	⚠	A605S3E20P4	PCB H (U)	1	
86		A8251-3180	SPACER	1	
87		ANE32628U0AP	SPRING	3	

# DOOR ASSEMBLY

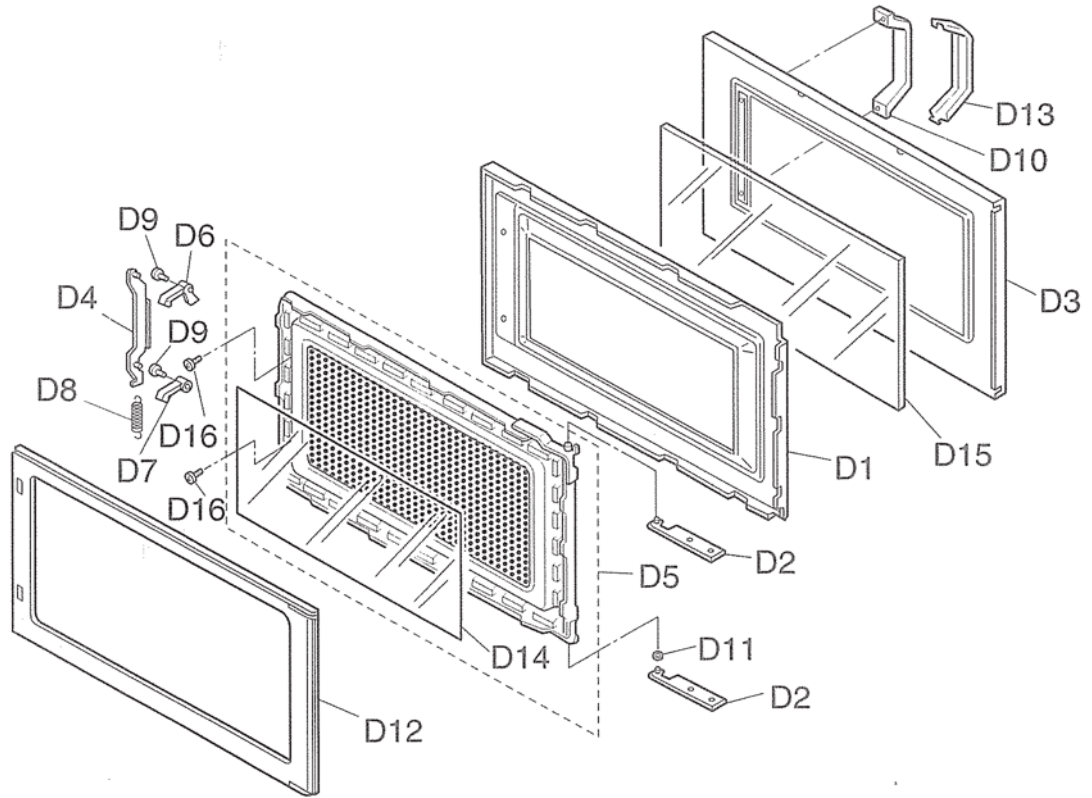

(S-331 QPQ)

Ref. No.	Safety	Part No.	Part Name & Description	Pcs/set	Remarks
D1		ANE30038U0AP	DOOR FRAME (U)	1	
D2	⚠	ANE30078U0AP	HINGE	2	
D3	⚠	ANE301A8U0AP	DOOR A	1	
D4		ANE301H-3850	DOOR KEY LEVER B	1	
D5	⚠	ANE301Q-3500	DOOR E (U)	1	
D6		ANE3018-3850	DOOR KEY	1	
D7		ANE3019-3850	DOOR KEY B	1	
D8		ANE30218U0AP	DOOR KEY SPRING	1	
D9		ANE30562Q0AP	HANDLE PIN	2	
D10		A30703170GP	HANDLE PEICE A	1	
D11		ANE3081P60AP	DOOR HINGE SPACER	1	
D12		ANE30858U0AP	DOOR C	1	
D13		ANE31348U0AP	HANDLE PEICE B	1	
D14	⚠	ANE3145-3500	DOOR SCREEN A	1	
D15		ANE31468U0AP	DOOR SCREEN B	1	
D16		XYEA4+C16TSJ	SCREW	2	4X16

# ESCUTCHEON BASE ASSEMBLY

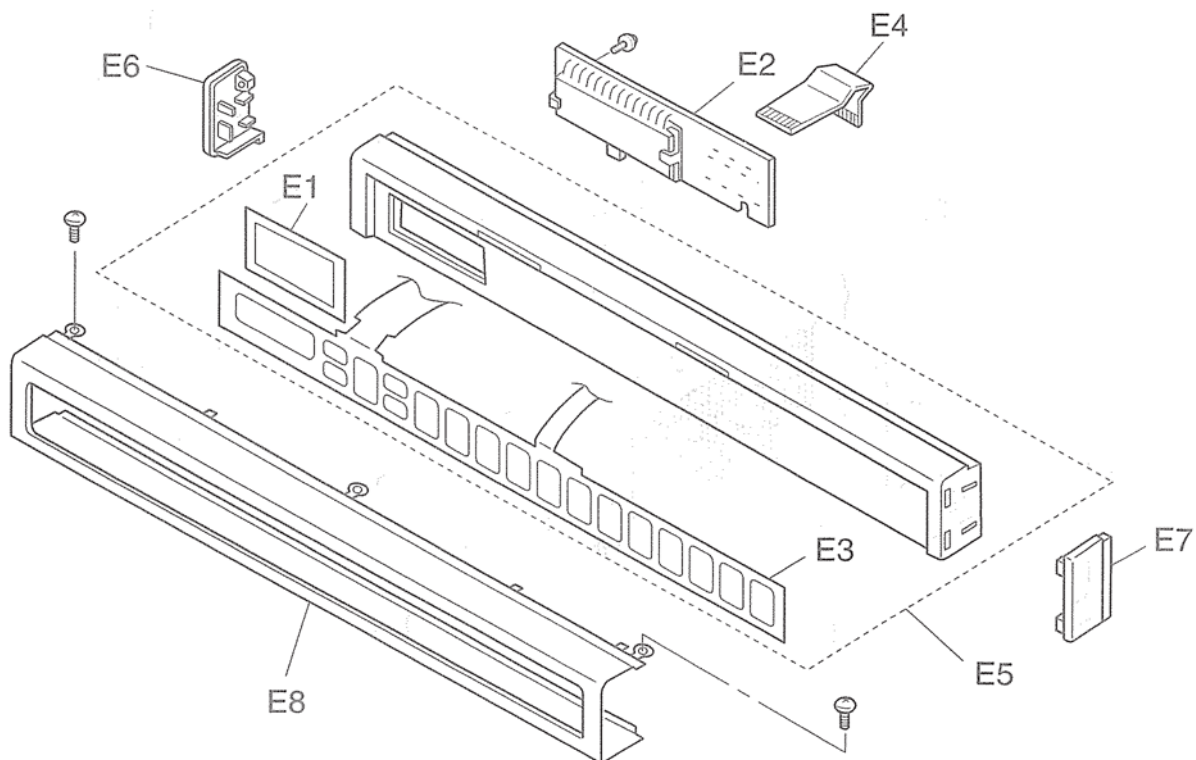

(S-331 QPQ)

Ref. No.	Safety	Part No.	Part Name & Description	Pcs/set	Remarks
E1		A8016-3B10	SPACER	1	
E2		A603M-3B10	PC BOARD B (U)	1	
E3		A83373F90QP	ESCUTCHEON SHEET	1	NE-1753ZPE
E3		A83373F90WT	ESCUTCHEON SHEET	1	NE-1853WTK
E3		A83373F90XP	ESCUTCHEON SHEET	1	NE-1753XPE
E4		A6590-3E20	FLAT CABLE	1	
E5		ANE801N8U0AP	ESCUTCHEON A (U)	1	
E6		A80023E20P3	ESCUTCHEON B	1	
E7		A80063E20P3	ESCUTCHEON D	1	
E8		A800L3F80ZP	ESCUTCHEON BASE U	1	NE-1753ZPE
E8		A800L3F90WT	ESCUTCHEON BASE U	1	NE-1853WTK
E8		A800L3F80XP	ESCUTCHEON BASE U	1	NE-1753XPE

# PACKING AND ACCESSORIES

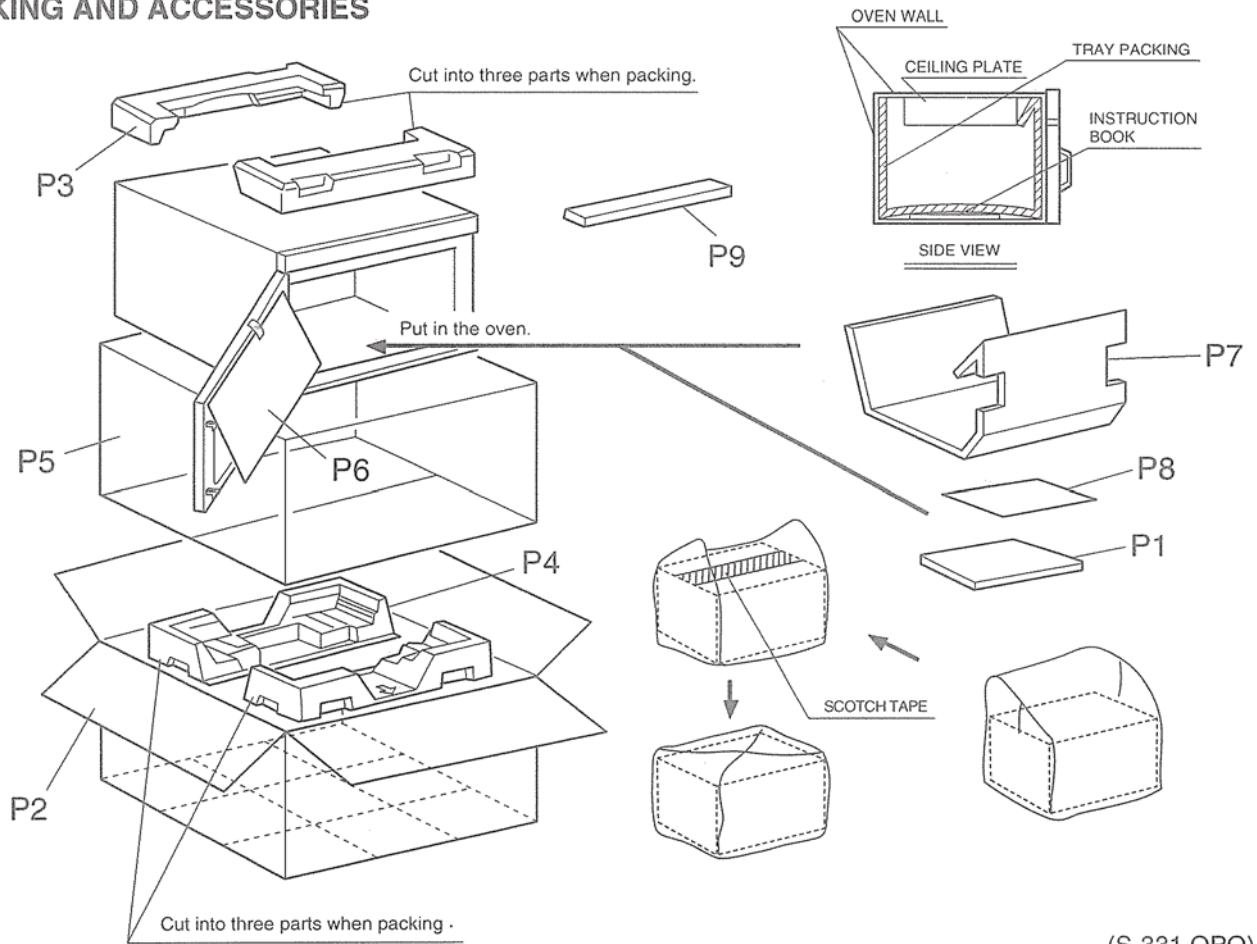

(S-331 QPQ)

Ref. No.	Safety	Part No.	Part Name & Description	Pcs/set	Remarks
P1	⚠	A00033F90WT	INSTRUCTION BOOK	1	NE-1853WTK
P1	⚠	A00033F80ZP	INSTRUCTION BOOK	1	NE-1753ZPE
P1	⚠	A00033F80XP	INSTRUCTION BOOK	1	NE-1753XPE
P1		A04203F90WT	OPERATING GUIDE	1	NE-1853WTK
P2		A01023F90WT	PACKING CASE, PAPER	1	NE-1853WTK
P2		A01023F80ZP	PACKING CASE, PAPER	1	NE-1753ZPE
P2		A01023F80XP	PACKING CASE, PAPER	1	NE-1753XPE
P3		ANE01048U0AP	UPPER FILLER	1	
P4		ANE01058U0AP	LOWER FILLER	1	
P5		A01065200AP	VINYL COVER	1	
P6		ANE01072Q0AP	DOOR SHEET B	1	
P7	⚠	A01083310GP	TRAY PACKING	1	
P8		A04203F90WT	OPERATING GUIDE	1	NE-1853WTK
P8		A04203F80ZP	OPERATING GUIDE	1	NE-1753ZPE
P8		A04203F80XP	OPERATING GUIDE	1	NE-1753XPE
P9		A01453230BP	DOOR SHEET B	1	

# WIRING MATERIAL

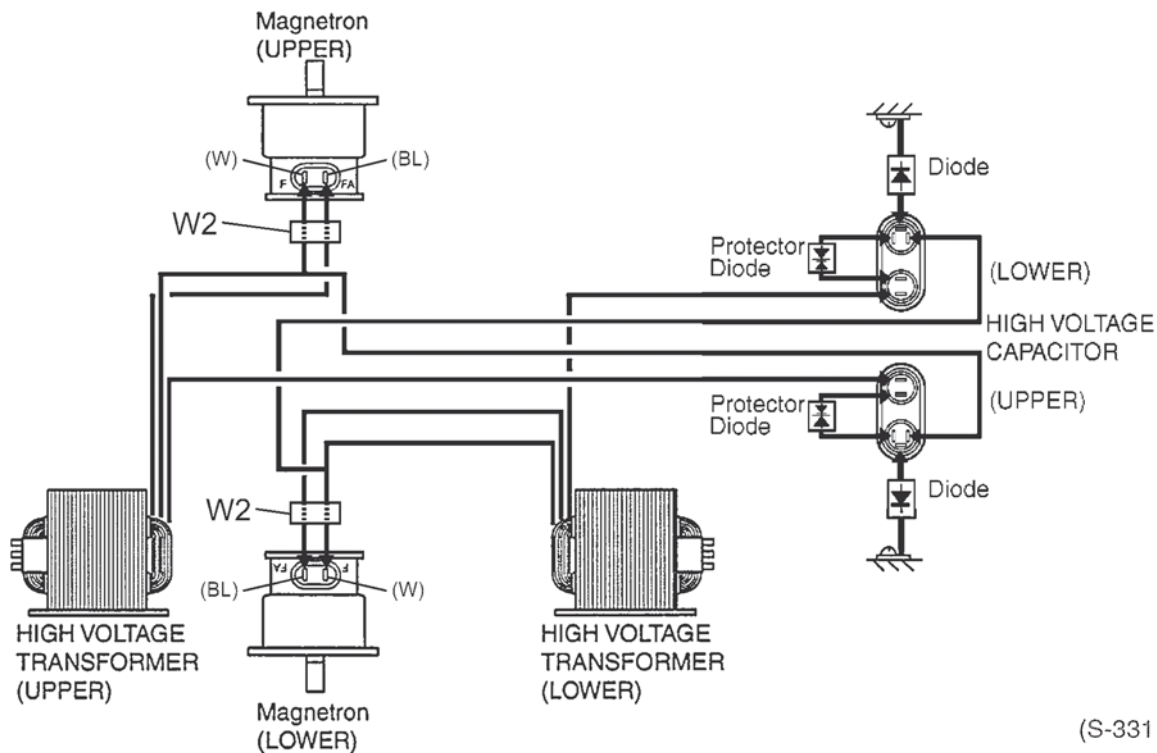
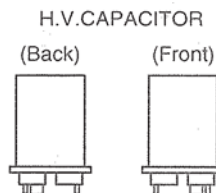
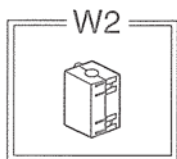
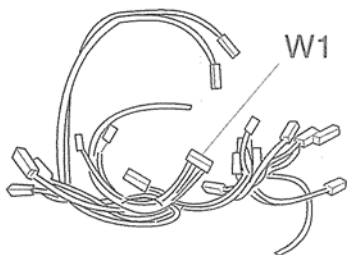

(S-331 QPQ)

Ref. No.	Safety	Part No.	Part Name & Description	Pcs/set	Remarks
W1	⚠	A030A3F90EU	LEAD WIRE HARNESS	1	
W2	⚠	A0KG00000169	FERRITE CORE	2	NE-1853WTK, NE-1753ZPE/XPE
W5		A0352-3280	LEAD WIRE	1	