

Models:

AROMA SM / SE

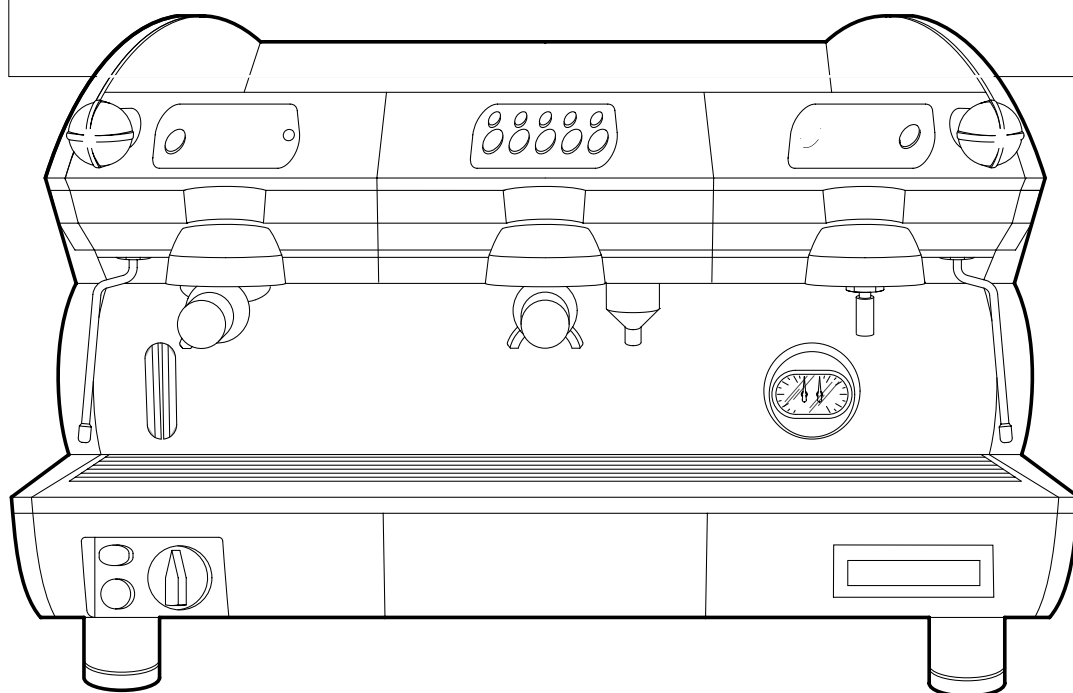

We thank you for your custom in the purchase of this product.
By carefully following the instructions contained in this manual you will be sure to appreciate the quality of our machine.
Please therefore carefully read the instructions of use contained in this manual, which comply with essential safety regulations.



Carefully read the following instruction booklet before starting up the machine.



Carefully read the following instruction booklet before starting up the machine.



Important ! Hot surfaces.



Important! Particularly important and/or delicate operations



Important ! Operations essential to guarantee efficient function



Operations which may be carried out by the user



Operations to be undertaken solely by an **installer or authorized technician.**

INDICE

INDICE	3
1- INSTRUCTIONS BOOKLET CONSERVATION AND USE	4
2- ENVISAGED MACHINE USE	4
3 - SAFETY ADVICE	5
4 - TECHNICAL FEATURES	6
5 - INSTALLATION	7
5.1 Water connection	7
5.2 Electrical connection	7
6 - START UP	8
6.1 Long coffee gicleuri	8
6.2 Pressure switch adjustment	9
6.3 Pump pressure calibration	9
6.4 Filters for coffee machine	9
6.5 Replacement of the thermostat to reduce the coffee dispensing group temperature	10
6.6 With spouts	10
7 - FUNCTION / USE AND PROGRAMMING	10
7.1 Coffee measure programming	11
7.2 Tea measure programming (hot water)	13
7.3 Coffee delivery	14
7.4 Continuous coffee measures	14
7.5 Special functions	15
7.6 Tea delivery	16
7.7 Cappuccino and milk function	17
7.8 Cappuccino delivery and programming	18
7.9 Milk programming and delivery	18
7.10 Further functions on machines equipped with display	19
7.11 Alarm condition	22
8 - PURIFIER REGENERATION	23
9 - MAINTENANCE AND USEFUL ADVICE	24
10 -TROUBLE SHOOTING	25
11 -MACHINE DISMANTLING	25

1 - INSTRUCTIONS BOOKLET CONSERVATION

The present instructions booklet has been prepared for the machine user, the owner and the installation technician and must be always available for reference purposes.

The manual is destined for the user, the maintenance technician and machine installation technician.

The purpose of the instructions booklet is to indicate the envisaged uses of the machine for which it has been designed, its technical features and in order to provide advice on correct use, cleaning and regulation. It also provides important maintenance information, and details on any residual risks, and all those operations which require particular care.

The present manual is to be considered as an integral part of the machine and must be CONSERVED FOR FUTURE REFERENCE until the final dismantling of the machine.

This instructions booklet must always be available for consultation and must be kept in a protected and dry place.

In the event of loss or damage to the same, the user may ask the manufacturer or local dealer for a new manual, indicating the machine model and serial number of the same as indicated on the identification plate.

The present manual reflects the state of the art, at the time of its preparation, the manufacturer however reserves the right to revise production and subsequent manuals without being obliged to update previous versions.

The manufacturer declines all responsibility in the event of :

- the improper or incorrect use of the coffee machine
- use that fails to comply with that specifically stated in the present booklet
- serious lack of maintenance as envisaged or recommended
- machine modifications or any non-authorized intervention
- use of either non-original or non-specific spares
- total or partial failure to observe the instructions

2. ENVISAGED MACHINE USE

The machine must be operated by a single operator only.

The authorized operator must have firstly read and fully understood all the instructions contained in the present booklet to ensure correct machine function.

This machine is specifically intended for the professional preparation of espresso coffee using blended coffee, as well as the drawing and delivery of water and/or steam.

Its components are made of resilient non toxic materials, and they are easily accessible for cleaning or maintenance operations.

This machine is intended for internal use only.
Ambient temperature for the correct operation of the machine 5°C ÷ 40°C.

3 - SAFETY ADVICE



The machine is to be used solely by adults who have carefully read and fully understood this manual and all the safety advice contained in the same.

The user is responsible in relation to third parties in the working area.

The installer, user and maintenance technician are obliged to notify the constructor of any defects or faults which may effect the original safety of the system.

Installation must be effected solely by authorized and qualified personnel.

The machine is to be used solely in the presence of suitable lighting.

For safety reasons, all worn or damaged parts must be promptly replaced.

Regularly check that the power supply cable is in good conditions. Damaged cables must never be repaired using insulating tape or clamps.

Do not expose the machine to the elements (sun, rain , etc).

Prolonged machine standstill at temperatures of under 0°C (zero degrees centigrade), may cause serious damage or breakage to the boiler piping: it is therefore necessary to completely empty the water circuit before every prolonged standstill.

The removal of guard and/or safety elements fitted on the machine is forbidden.

The packaging components must be consigned to special disposal centres and must in any event never be left unguarded or within reach of children, animals or non-authorized persons.

The constructor declines responsibility for any damage to things, persons or animals caused by eventual interventions on the machine by personnel not specifically authorized to undertake such operations.

In the event of any non-authorized interventions or repairs on the machine, or in the event of the use of non-original spares all guarantee terms become void, and the company reserves the right to reject validity.

The user must comply with the current safety laws in force in the country of installation, as well as common sense and ensure that all maintenance operations are regularly carried out.

Never clean the inside of the machine with power supply on and plug connected and in any event avoid the use of water sprays or detergents.

The user must not touch the machine if his hands or feet are wet or damp, neither must be use the machine in bare feet. Although the machine is earthed it is advisable to use wooden platforms or a cut-out box complying with local laws in order to prevent the risk of electrocution.

4 - TECHNICAL FEATURES

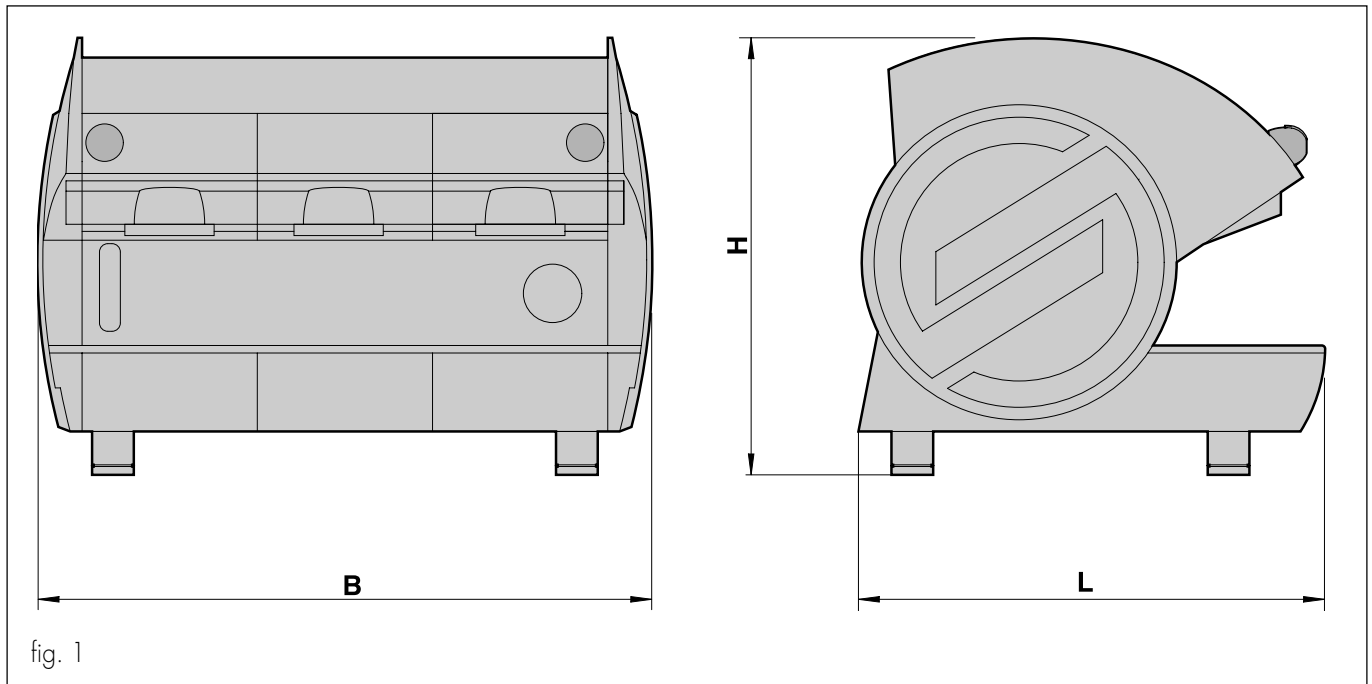

		2 groups	3 groups	4 groups	
Dimensions	B	760	970	1180	
	H	530	530	530	
	L	540	540	540	
Weight	kg	70	90	110	
Boiler capacity	L	13	21	28	
Boiler resistance absorbed power					
	240 / 415 V 3 N ~	W	4760	5950	7140
	230 / 400 V 3 N ~	W	4370	5465	6555
ECO Max boiler resistance absorbed power					
	240 / 415 V 3 N ~	W	3170	3950	4750
	230 / 400 V 3 N ~	W	2900	3640	4360
Pump motor		W	165	165	165
Overall absorbed power					
	230-240/400-415 V 3 N ~	W	5200	6200	7200

5 - INSTALLATION

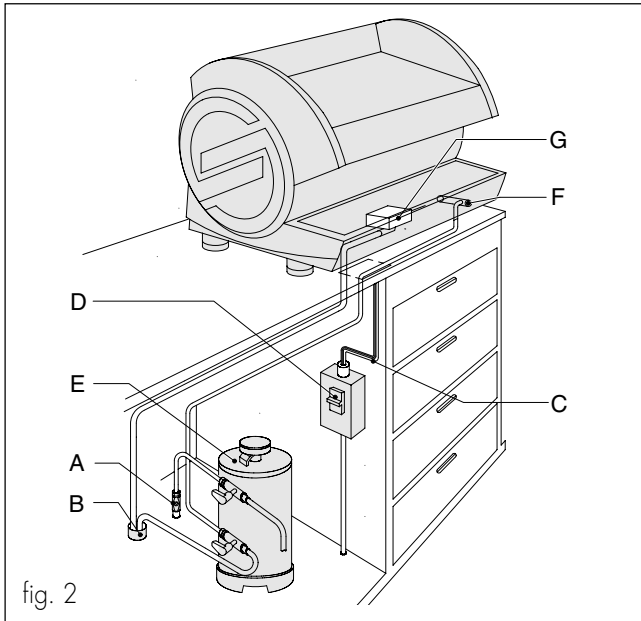

fig. 2

- A. MAINS SUPPLY
- B. DISCHARGE DUCTS
- C. POWER CABLE
- D. PROTECTION SWITCH
- E. PURIFIER
- F. BOILER SUPPLY TAP
- G. DRIP BOWL

Before proceeding with installation check that:

- there are no bumps, signs of knocks or deformities.
- 1 there are no damp patches or marks which could lead one to assume that the packaging has been exposed to the elements
- 2 there are no signs of tampering

Once one is satisfied that transportation has been correctly effected proceed with installation.

Proceed with installation following the instructions according to the sequence as described below.

N.B. The least height of the support's top must be 110cm.

5.1 Water connection

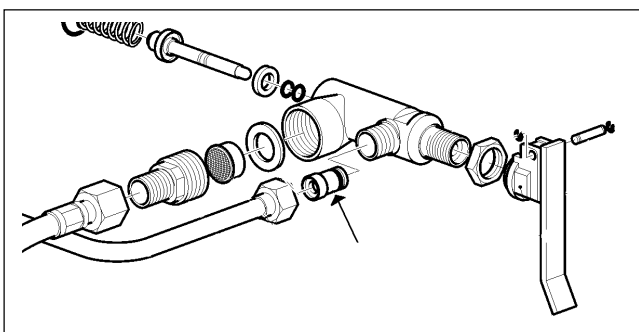

IMPORTANT



Before connecting to the water mains, assemble the one-way valve (valvola di non ritorno), indicated in the diagram, as follows:

Unscrew the nut, remove boiler filling valve pipe and insert the one-way valve with the gasket towards the boiler valve body. Reattach pipe, tighten the nut and connect to the water mains.



Important: The machine must be supplied with water of over 8°F hardness.

The installation of a water softener is recommended for the machine water supply.

Check that the water mains to which connection is to be made supplies drinking water.

- Connect purifier (E) to the water mains (A).



NB: before connecting the purifier to the machine, wash out thoroughly until the water becomes clear, then proceed to connect the purifier to the machine.

- Connect the drain cup (G) to the drainage pipe (B)
- Should the mains pressure be higher than 5 bar a pressure reducer balanced for high pressure should be installed (device in which any mains pressure increase does not effect the output pressure).



5.2 Electrical connection



Important ! Before proceeding with electrical connection it is necessary to check to ensure that the voltage rating corresponds with that indicated on the CE plate and on the connection plate on the power supply cable.

Check to ensure that the electrical supply line is able to support the machine load (see chap. 4 – technical features table).

Connect to an earthing socket which complies with current legislation.

Check that the power supply cable is efficient and that it complies with national and European safety standards.

The user must undertake to power the machine protecting the power line using a suitable safety switch (cut-out) that complies with the legislation in force in the actual country itself.

Connect the power cable (1) to the electric line using a plug, or in the case of fixed installation, using a multi-polar switch (D) for mains separation, with a contact distance of at least 3 mm.

For voltage change refer to the diagram shown on the general mains switch box.

The yellow-green coloured cable **MUST** be connected to the room's earthing system.



6 - START UP

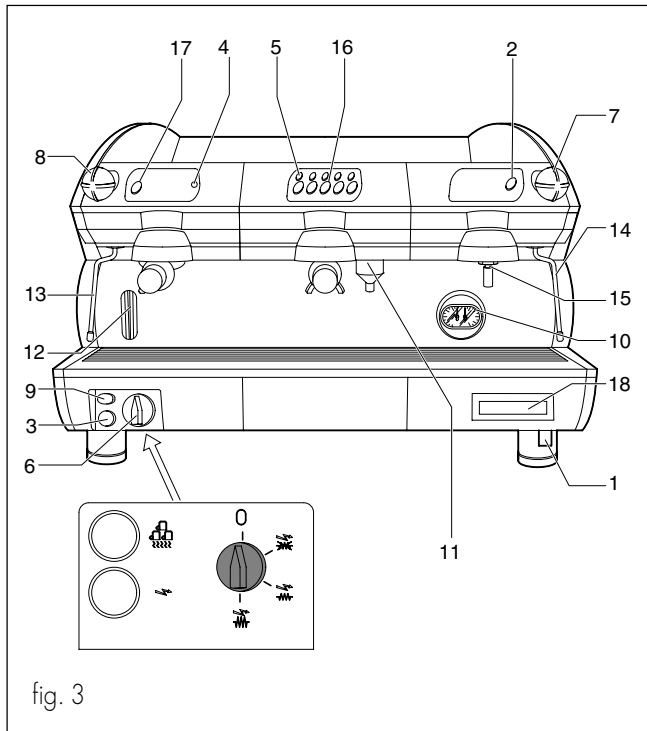



fig. 3



1. Loading boiler tap
2. hot water outlet button
3. hot water outlet switch
4. E delivery indicator
5. D delivery led
6. main switch
7. right vaporiser tap
8. left vaporiser tap
9. cup-warmer switch
10. boiler/pump pressure gauge
11. cappuccino maker
12. boiler level indicator
13. left vaporiser tap
14. right vaporiser tap
15. hot water outlet pipe
16. Unit D control keyboard
17. unit E control keyboard
18. optional dose-counter display

Once the water, gas and electrical connections have been made, proceed to start up the machine.

Open the mains water supply tap (A) (fig 2).
Close the protection switch (D) (fig 2).

Position the machine main switch (8) to position  the machine on indicator will come on (3).

The auto-levelling device will come into operation so that the water reaches a normal level in the boiler (12).

Position the main switch (6) to position  for operation at normal power or to position  for operation at full power, thereby powering the resistances.

Wait for the pressure to reach its operational pressure 1.1]1.3 atm checking the boiler pressure on the gauge (10).

Should the machine fail to stabilize on the indicated values it is necessary to calibrate the pressure switch as described in paragraph 6.2.

In the event of a machine featuring a gas heating system, it is necessary to switch on the gas by operating the gas valve (4) after operating the main switch (6), keeping the piezoelectric switch pressed (5) until the gas remains on.

Then check the pressure on the pump gauge (10) putting a unit into operation with filter holder engaged filled with ground, dosed and pressed coffee in order to achieve an effective working pressure of 8/9 atm.

Should re-calibration of the pump pressure be necessary this operation should be undertaken as indicated in paragraph 6.3.

The machine is now ready for use.



IMPORTANT:

Do not press the hot water delivery switch or button (2) before the correct working temperature of 1.1 atm is reached, as indicated on the boiler gauge (10).

6.1 Long coffee gigeur

The machine is fitted with a gigeur (1 per unit) with a clearance of 0.6 mm (Cod. WGA26G0074/01).

For greater coffee delivery speed, in the case of long coffees, no.2 gigeurs are also included with the machine (complete with seals) with a clearance of 0.8 mm (Cod. WGA26G0073/01). The gigeur is located in the exchanger supply fitting (1 per group).

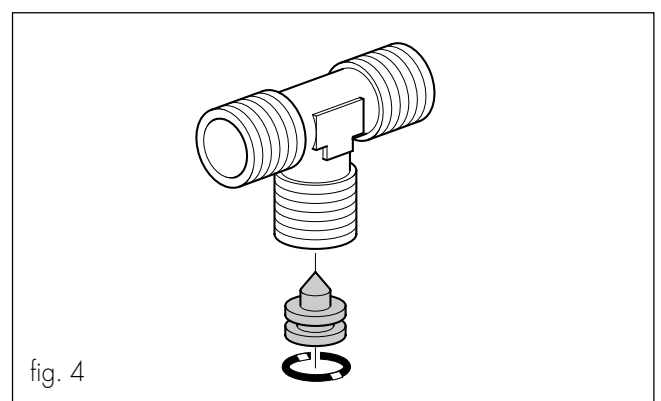

fig. 4

6.2 Pressure switch adjustment

The pressure switch shown in the figure acts to keep the boiler pressure constant by engaging or de-activating the electrical heating resistance.

This pressure switch is already calibrated to 1.1-1.3 bar during the initial machine testing stage, but should a different working pressure be required, it is possible to vary the operational field of the pressure switch using the regulation screw (U); pressure reduction results in a reduction in temperature, whilst increasing the pressure will also increase the water temperature. The regulation direction is shown in the figure and on the pressure switch itself. The pressure varies by 0.1 atm for every complete screw turn.



Warning: Disconnect the electricity supply before undertaking this operation.

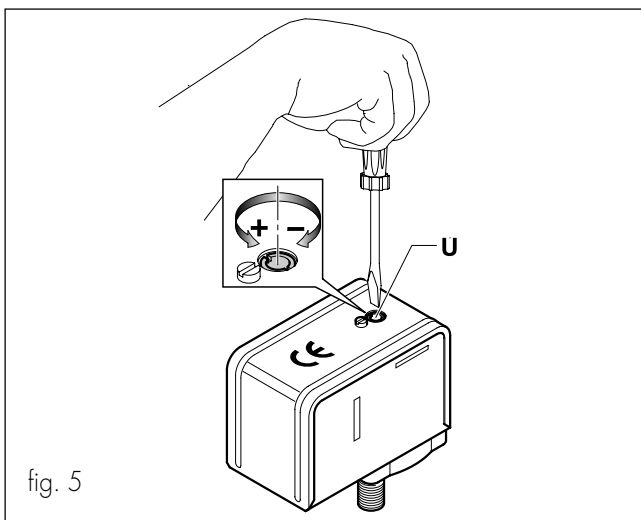

fig. 5

6.3 Pump pressure calibration

Insert the filter holder into the unit filled with regularly ground, dosed and pressed coffee.

Switch on the unit switch (AROMA SM) or the unit control keyboard (AROMA SE) (16) and read the pressure on the pump pressure gauge (10).

NB: The correct pressure is of 8-9 atm.

Should the pressure indicated on the pressure gauge be incorrect, turn it clockwise to increase the pump pressure and anti-clockwise to reduce the pressure.

Once adjustment is complete check pump calibration by delivering one or more coffees.

Z= Pump pressure adjustment screw.

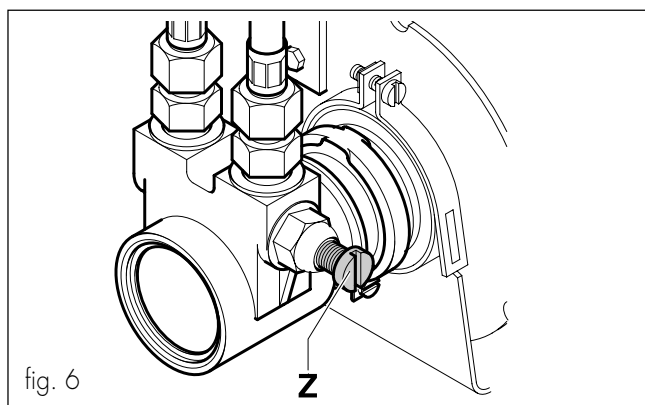

fig. 6



Warning !!

When the machine is new the filter-holder sump may not be aligned (perpendicular to the machine itself) as shown in the figure at the side, however this does not effect the efficient function of the same.

After a short period of use the sump will gradually settle into a correct position.

A = Position of closed filter-holder with new machine.

B = Position of closed filter holder with machine after a short period of use.

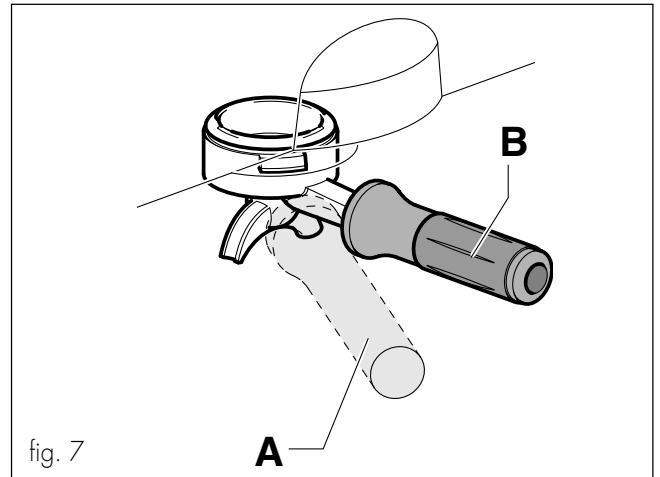

fig. 7



IMPORTANT: N°2 under-tile packings with are thinner (8.1 mm) than that fitted as standard are included. These packings may be used in the event of difficulty with insertion of the filter holder.

6.4 Filters for coffee machine

Depending on the quantity of coffee ground, the appropriate filter must be used as shown below to avoid that, once the coffee has dripped out, the leftover powder remains attached to the nozzle.

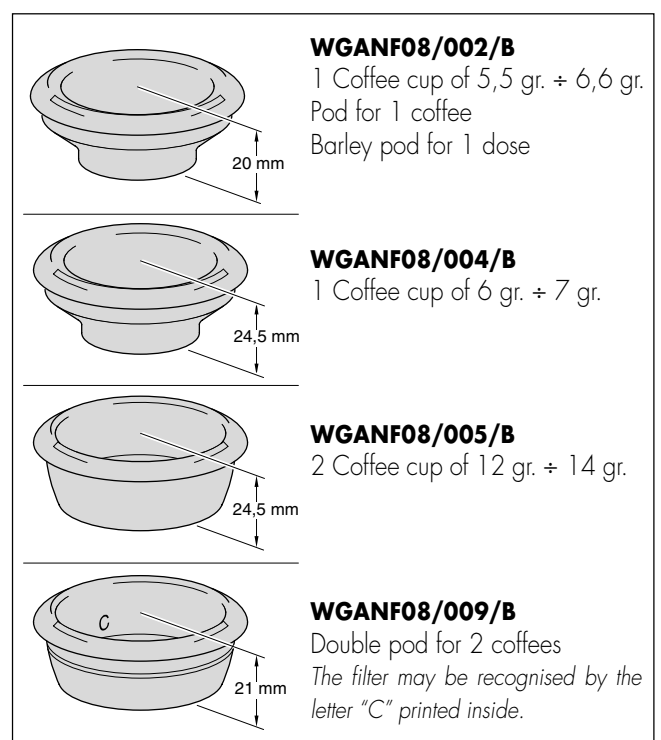

6.5 Replacement of the thermostat to reduce the coffee dispensing group temperature.

Remove cup heating bowl (1). Disconnect group thermostat (2) (Code WGADM1561 – T 103°C) and replace it with the lower temperature thermostat (Code WGADM1736 – T 98°C), included in the machine equipment.

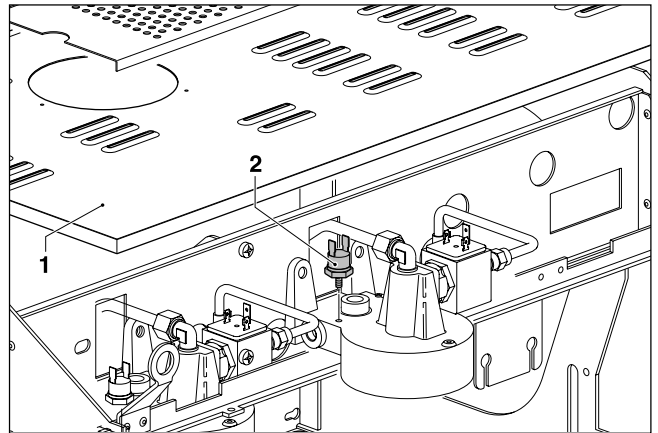

6.6 Spouts included in the supply.

No. 4 spouts are supplied with the machine to dispense one or two coffees. The figure (beside) shows the different distances from the cup-holding tray (H), depending on the different types of spouts fitted on the filter holder.

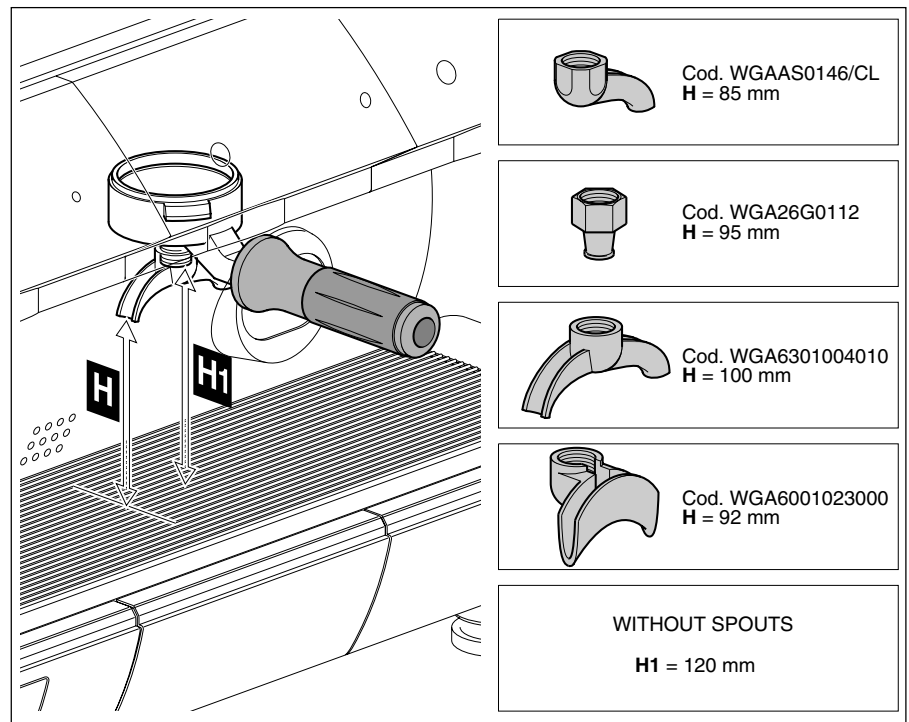

7. FUNCTION / USE AND PROGRAMMING INTRODUCTION

The programming software permits the checking of the following operations:

- handling of 2-3-4 coffee units
- simultaneous function of both coffee and tea units
- cappuccino/milk function
- volumetric check on coffee measures
- timed tea measure check
- simulated measure programming
- filling level check and control

- system supervision through alarms
- continuous, delivery time-out and further functions
- serial connection with accounting devices
- 16 X 2 LCD display (not rear-lit) for functional state display.

Important: the last selection made always appears on the display

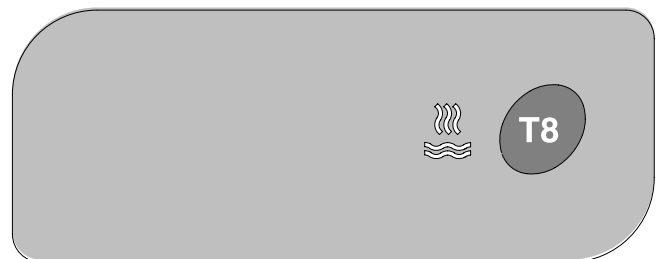
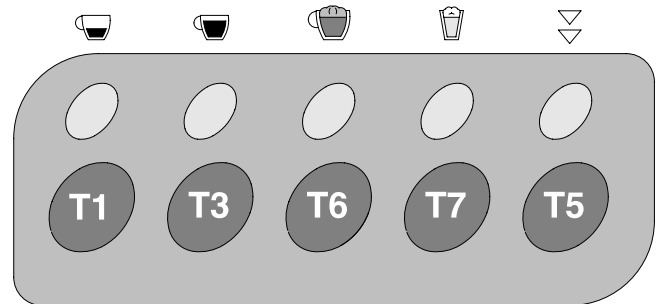
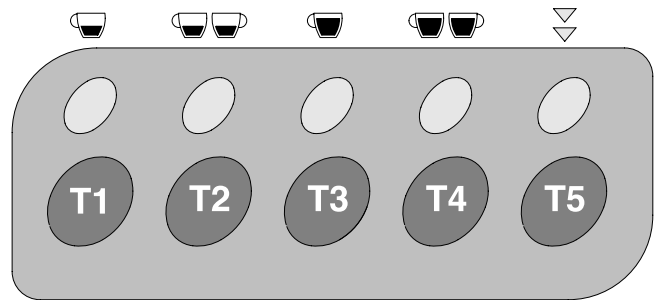
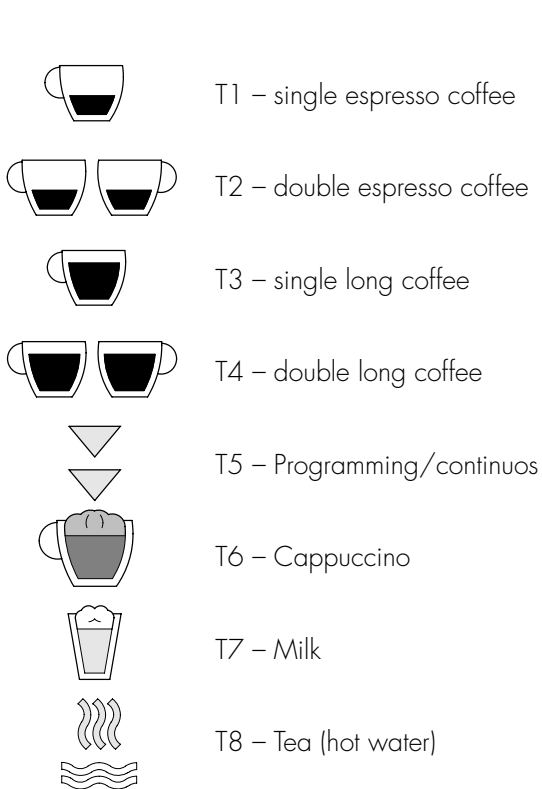

7.1 Coffee measure programming

The measured amounts of coffee may be modified (by means of volumetric checking) and memorized as follows:

- press key T5 (of keyboard relative to group 1) and keep pressed for over 5 seconds and check that all the keyboard leds come on. In which case, (by operating on the keyboard relative to group 1) all the units will be programmed, while by pressing key T5 of another unit, only the programming of the unit on which one is operating is possible.

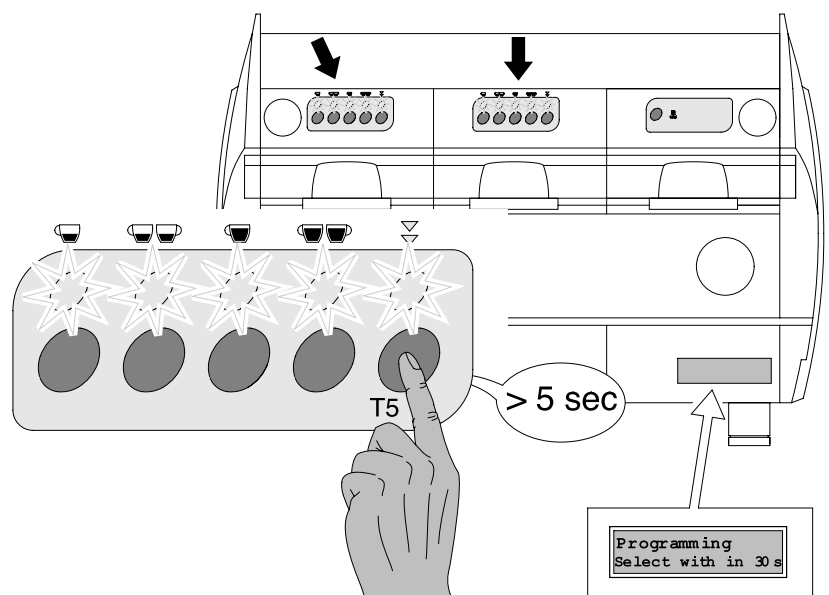

IMPORTANT !! The settings made on unit 1 (operating on the first keyboard) will be automatically copied on to all the other units.

Press the key corresponding to the measure to be programmed (key T1 for example) within 30 seconds (programming time-out).

The led relative to T5 will remain on, on all keyboards and the led relative to the measure being programmed will also come on (on all the keyboards). During this state and for the entire coffee measure programming time duration, the solenoid valve and pump are activated.

Note: If none of the keys are pressed within 30 seconds, it will automatically escape from programming mode.

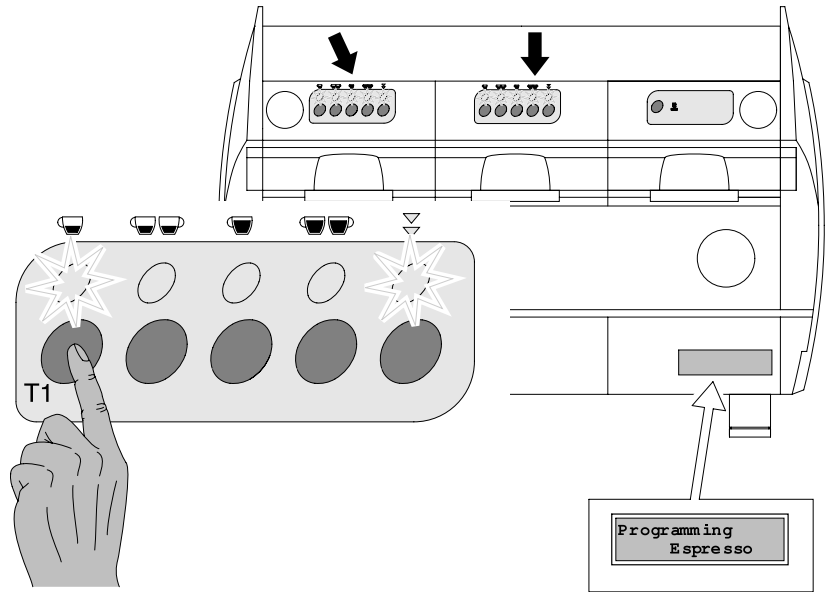

On pressing key T1 coffee delivery begins, once the required amount of coffee is obtained press key T1 again or any other of the keys of the unit keyboard in order to suspend coffee delivery. The new impulse value of the measure is thereby memorized on the EPROM. Both the solenoid valve and the pump are de-activated thereby suspending product delivery and all the keyboard leds go out.

To proceed with a new programming operation of other coffee measures T2-T3-T4 (providing that the programming time out time of 30 sec is not exceeded) simply repeat the same operations with the same sequence as undertaken for key T1.

Press key T5 to immediately escape from the programming stage.

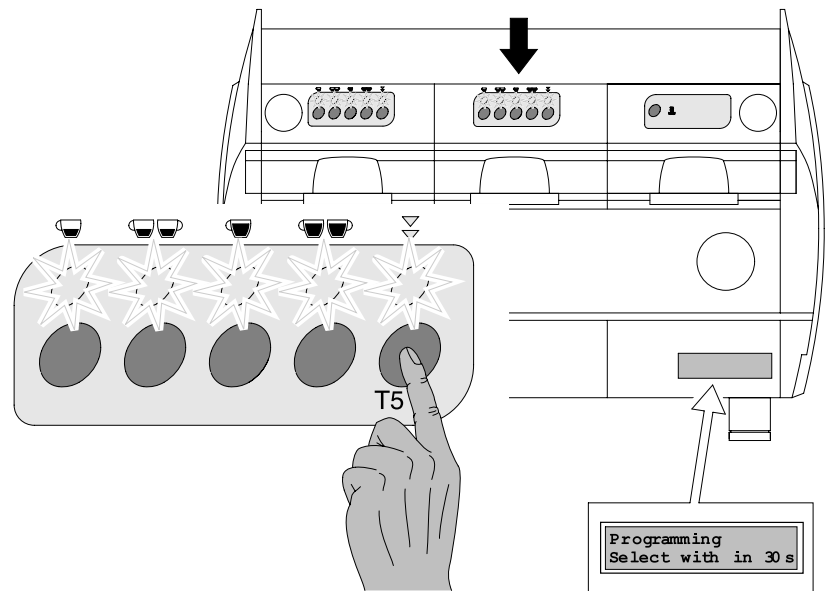

IMPORTANT: Should the "PRE-INFUSION" function be active (see par. 7.5). Wait until the pre-infusion function is complete before stopping delivery in progress.

NOTE: During the programming of a unit the function of the other units is deactivated as well as tea dispensing.

To programme the other units, press the specific programming key of each unit and carry out the same operations as undertaken on unit 1. In this case any variations in the measures are activated only on the unit on which one is actually working.

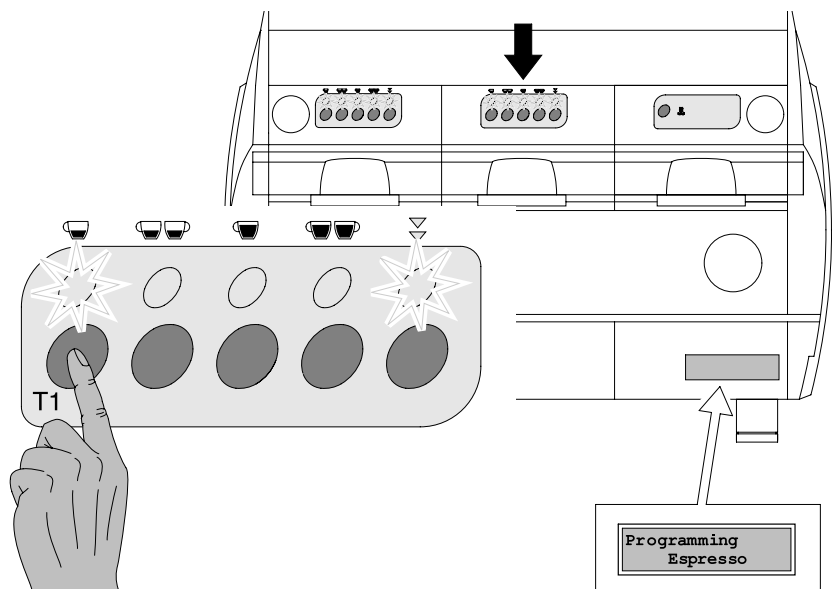

7.2 Tea measure programming (hot water)

It is possible to modify the timed tea measures according to the following sequence:

Press key T5 of coffee unit 1 and keep pressed down for over 5 seconds and check that all the keyboard led indicators come on.

Press the T8 tea key within 30 seconds (programming time-out).

This begins the tea water delivery operation.

Once the required measure is obtained press T8 again to suspend water delivery. In this way the new tea water delivery time is memory and all the keyboard leds go out.

Press key T5 again to immediately escape from the programming phase.

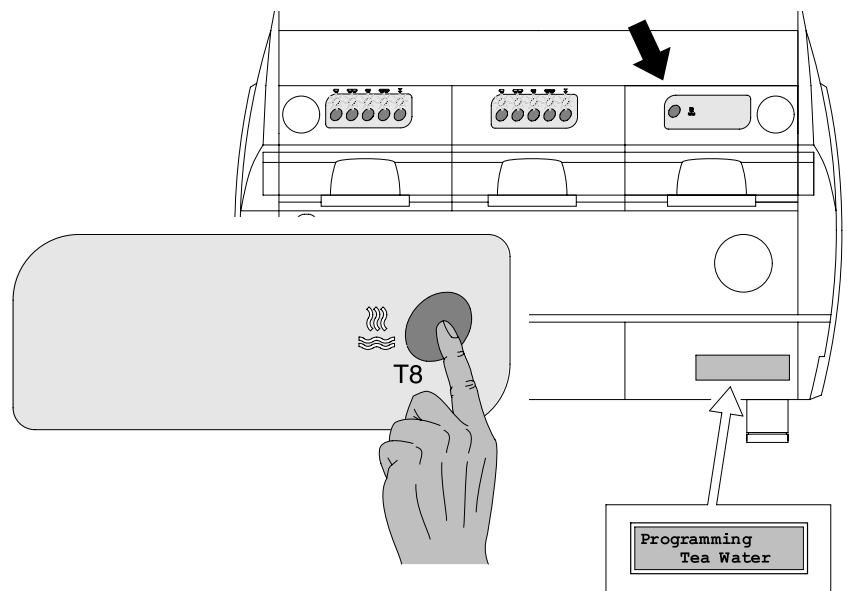
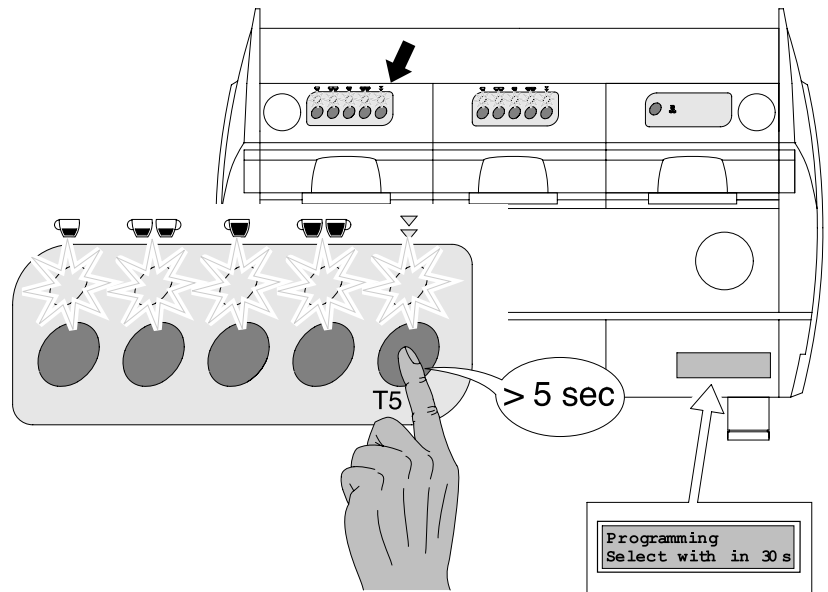

7.3 Coffee delivery

On pressing the corresponding key T1-T2-T3 or T4, the corresponding delivery solenoid valves are activated for the time necessary to obtain the required amount of product as previously programmed (volumetric check).

The LED relative to the selected measure remains on for the entire coffee delivery time.

The delivery in progress may be suspended before actually reaching the desired programmed product quantity by pressing any of the measure keys present on the keyboard of the unit used for product delivery.

It is also possible to obtain simultaneous coffee delivery from all the machine units.

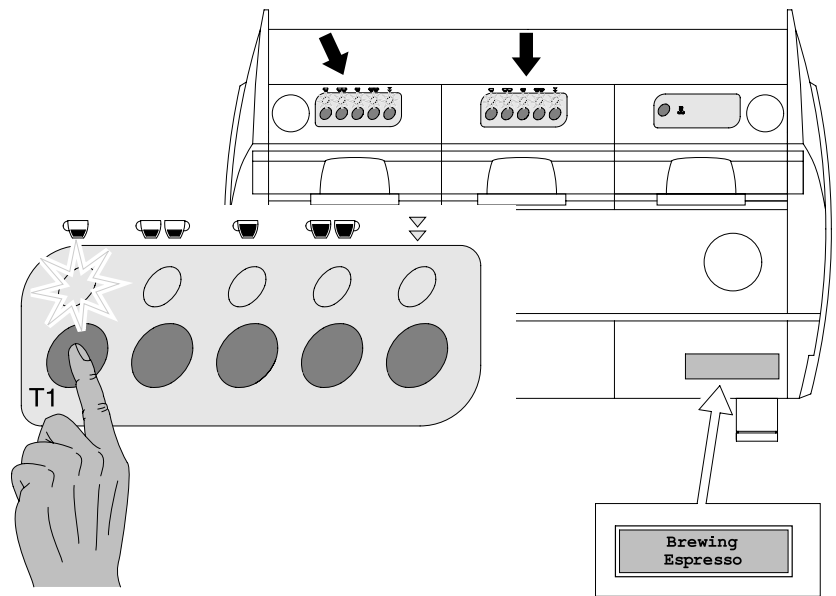

7.4 Continuous coffee measures

For continuous coffee measure delivery press key T5 from the keyboard corresponding to the unit on which one wishes to operate.

The LED corresponding to key T5 will remain on for the entire delivery operation.

IMPORTANT ! Avoid keeping it pressed for more than 5 seconds or it will enter the programming mode.

Coffee delivery will continue until measure stop by pressing key T5, or on obtaining the maximum amount of product which can be obtained through volumetric control (6000 impulses) or by means of delivery Time-out function.

IMPORTANT ! The start of the relative "continuous" cycle occurs on the release (within 5 seconds) of key T5 and not on pressing of the same. While the STOP function may be obtained by pressing it a second time.

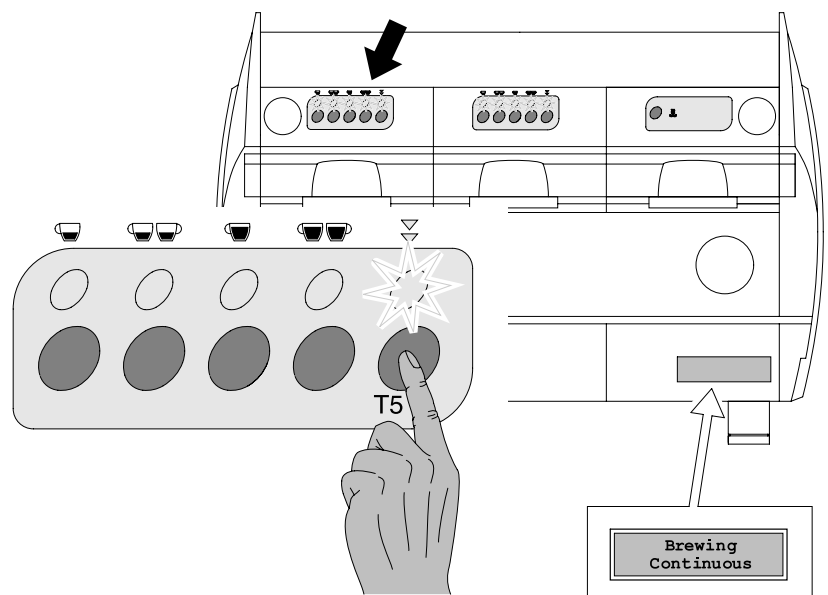

7.5 Special functions

It is possible to engage or deactivate certain special functions such as PRE-INFUSION, MIXED TEA and WASHING ALARM which we shall describe below:

Washing alarm

This function acts to indicate, after 10 minutes from the start of the delivery of the cappuccino or milk, the following signal "Run Milk Clean" and the alternating flashing of the LEDs corresponding to keys T6 and T7 which indicate that a milk or cappuccino has been prepared and the milk section therefore needs to be cleaned. To temporarily cancel the alarm function press key T6 or T7.

Cappuccino machine cleaning

Cleaning to be undertaken when the "Run Milk Clean" message appears with the alternating flashing of the LEDs corresponding to keys T6 and T7.

Take a 1 litre container full of cold water. Remove the milk suction pipe from the container and place inside the container itself.

Press keys T7 and T5 at the same time (on the keyboard activated for the "service" functions) this engages the milk delivery function, the water flow will clean the cappuccino machine.

Once all the water has been suctioned, stop delivery by pressing key T7.

Pre-infusion

Our software permits measure configuration so that the relative delivery of the COFFEE measures through volumetric control is preceded by pre-infusion. Delivery of the coffee measure after time 1 (ON) is suspended for a time 2 (OFF) and is then resumed for the completion of selection.

On pressing one of the volumetric control measure keys, the normal delivery cycle is preceded by a short timed water jet in order to dampen the coffee pellets before actual delivery stage.

This function ensures the optimum use of the coffee pellets.

Mixed tea (hot water)

On the engagement of this function the water delivered is mixed with cold water on entry in the boiler thereby ensuring constant delivery at a temperature of about 96°C.

If this function is not engaged water is delivered at a temperature of about 100°C and is highly vaporized.

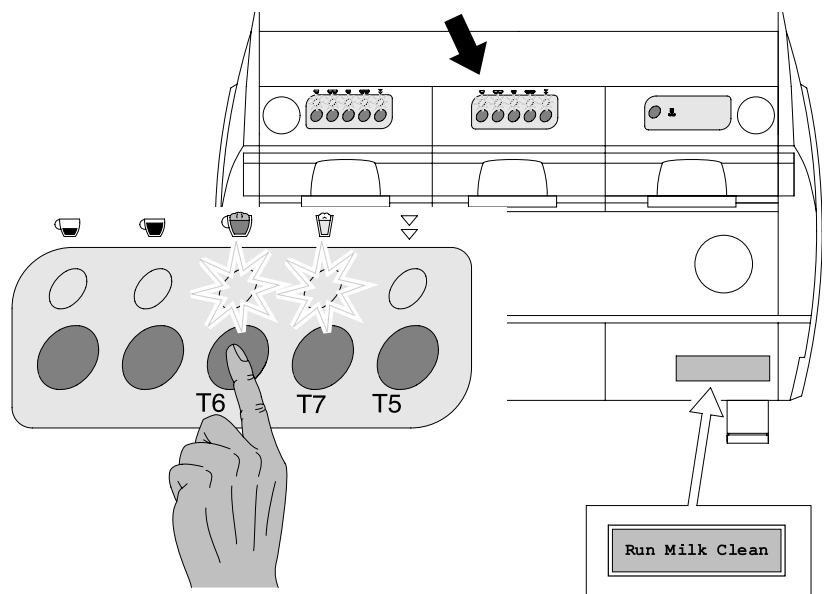

Engagement/deactivation

Start the machine by pressing the main switch keeping key T5 of unit 1 pressed and wait for the led relative to key T5 to begin flashing.

Press keys T1-T2 and T3 in order to engage or deactivate the PRE-INFUSION, MIXED TEA and WASHING ALARM functions.

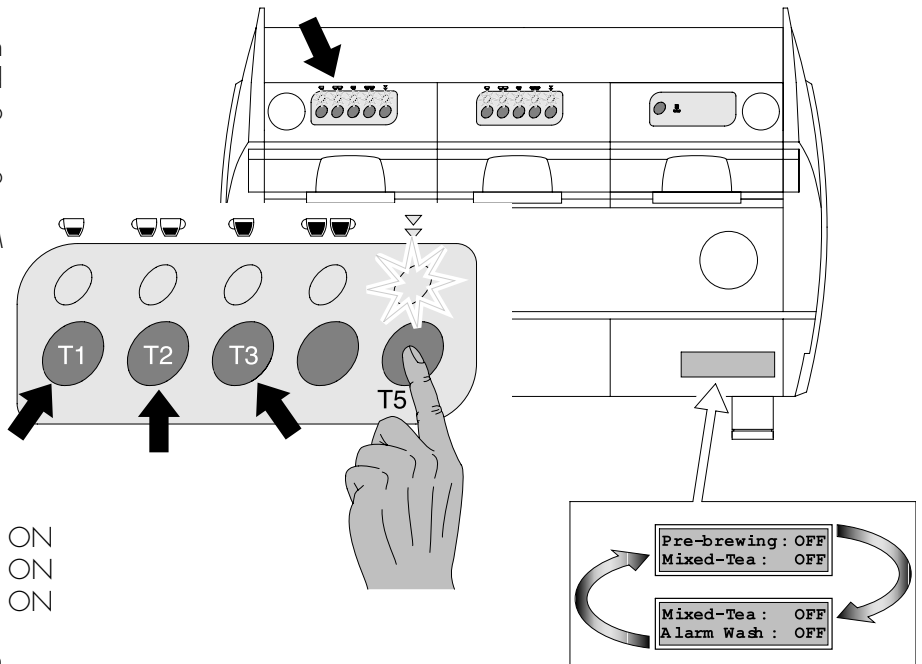

- T1 KEY LED ON : PRE INFUSION: ON
- T2 KEY LED ON : MIXED TEA: ON
- T3 KEY LED ON : WASHING ALARM: ON

To escape from this condition and return to normal functions press key T5 again.

7.6 Tea delivery

On pressing key T8 the corresponding solenoid valve is engaged thereby beginning hot water delivery.

On START a timer is activated which interrupts the water delivery on reaching the time set during the programming stage. The simultaneous delivery of tea or coffee is possible.

It is possible to interrupt delivery function in progress before the programmed time is reached by pressing key T8 again used for product delivery.

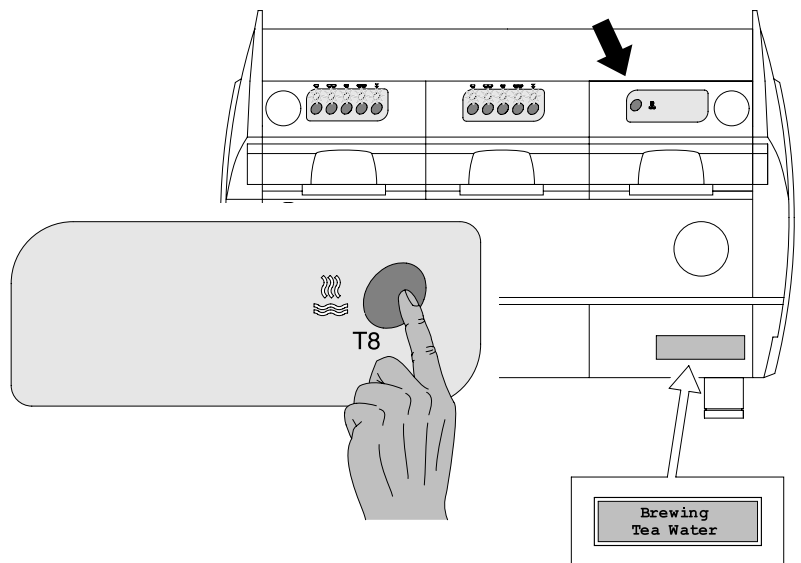

7.7 Cappuccino and milk function

It is possible to set the CAPPUCCINO and MILK function on keys T6 and T7 on group 2, 3, or 4.

IMPORTANT : The function can be set on only one keyboard at a time, on unit 2, 3 or 4.

Engagement/ deactivation

In order to set the function on the keyboard of unit 2, for example, keep key T5 pressed down and the corresponding LED will begin flashing until the wording "SERVICE OFF" appears on the display.

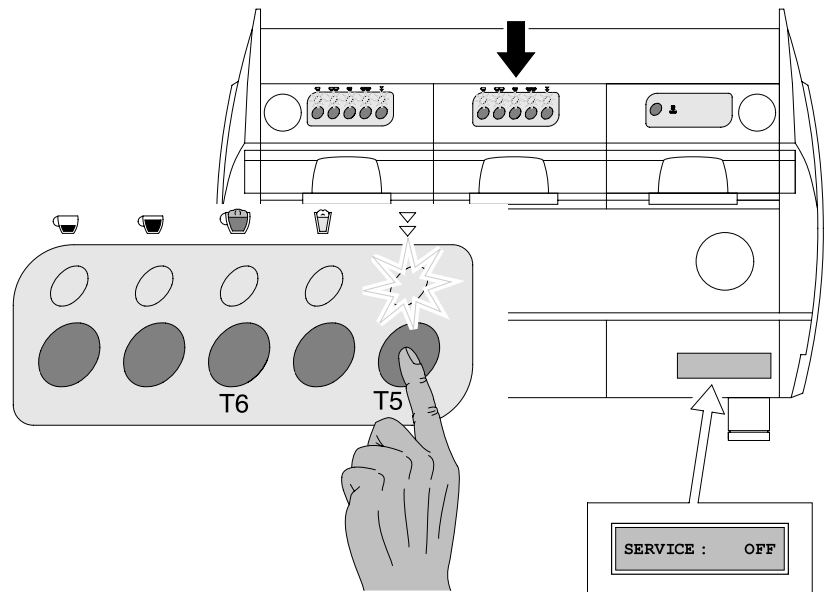

Press key T1 of keyboard 2 in order to engage the Cappuccino/milk function on the 2nd unit.

T1 KEY LED ON : SERVICE: ON

Proceed in the same way to engage this function on the keyboard of another unit.

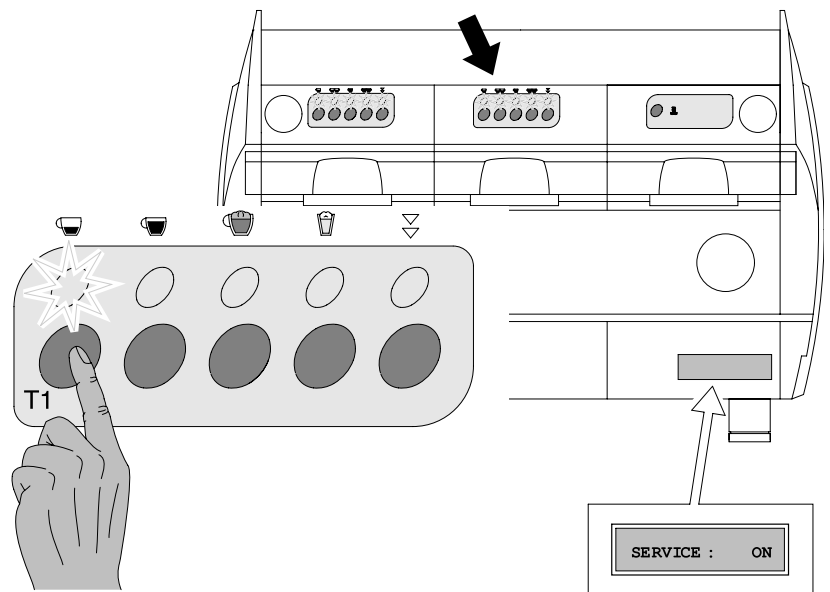

7.8 Cappuccino delivery and programming

When engaged key T6 will determine the activation of the solenoid valve and pump according to the value set during programming.

To programme the cappuccino function, proceed in the same way as for coffee with the only difference being that at the end of the volumetric delivery of the coffee, the timed milk delivery **BEGINS SEPARATELY**. Once the desired quantity is obtained stop delivery using key T7.

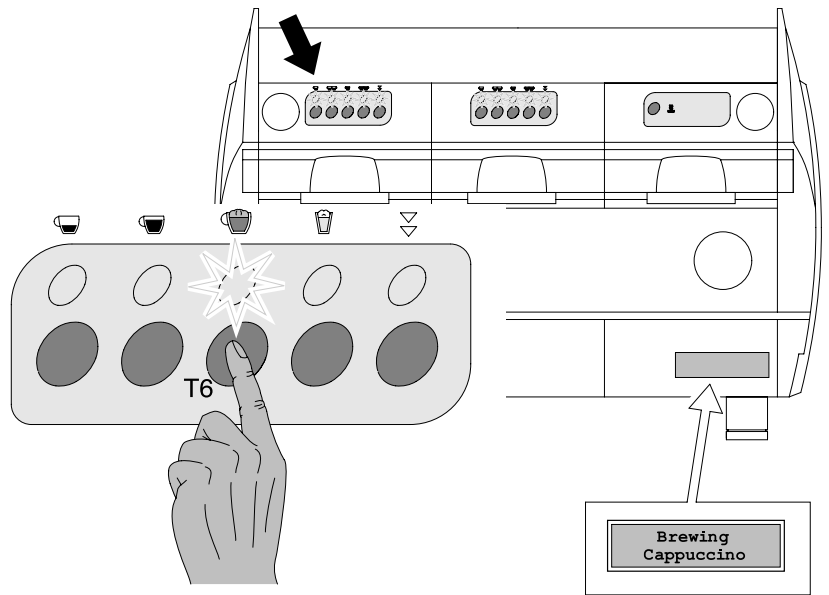

7.9 Milk programming and delivery

Key T7 when engaged determines the activation of the solenoid valve according to the value set during programming. The programming of this function is the same as that for TEA.

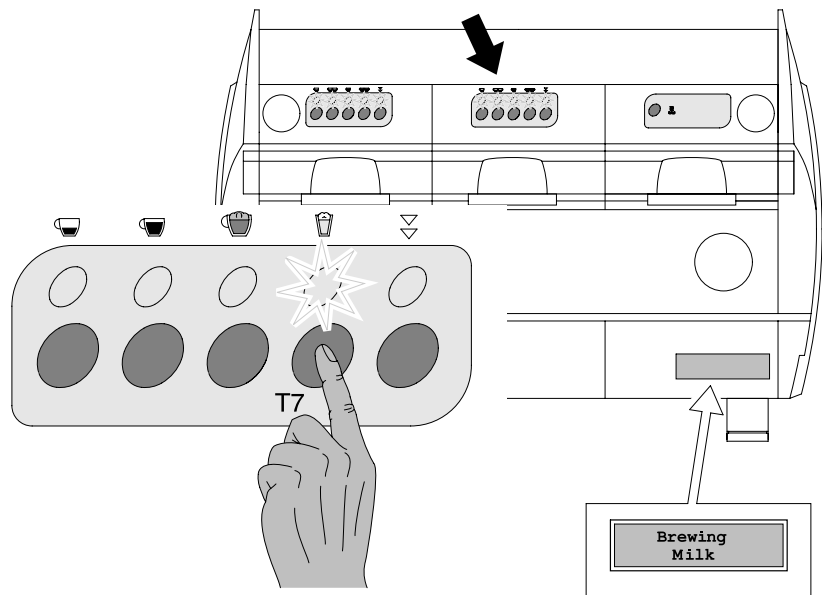

7.10 Further functions on machines equipped with display

Language selection

In order to select the consultation language, on switching on, press key T4 and keep pressed.

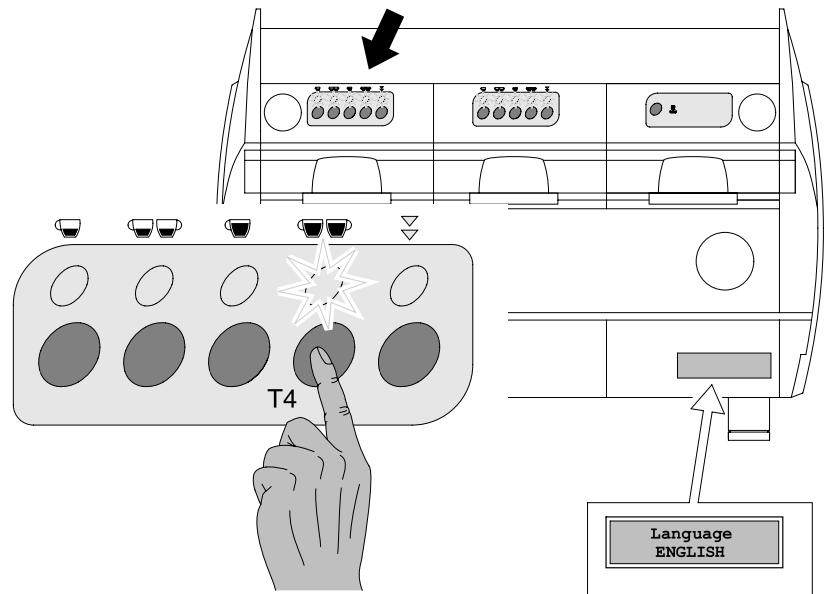

Press key T1 several times to select the desired language, press T4 again to confirm selection.

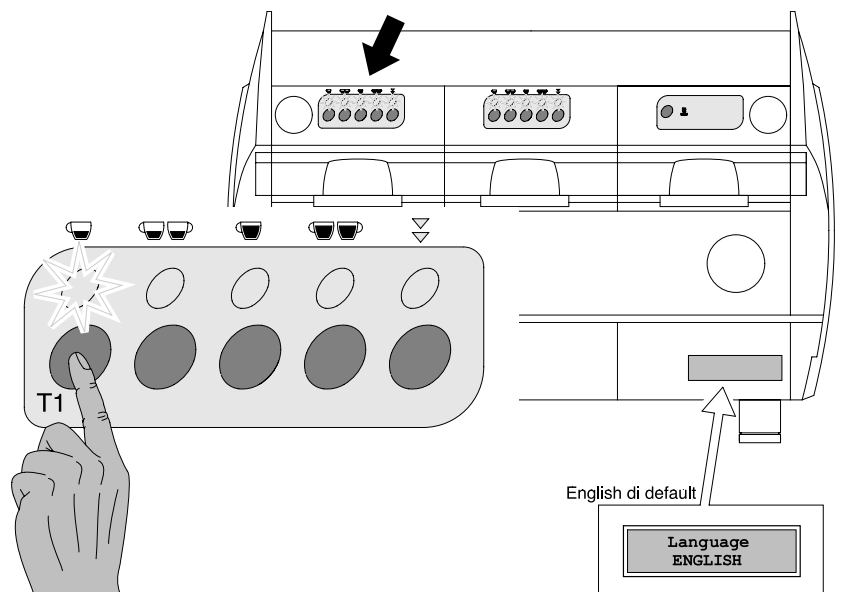

Consumption reading

It is possible to read the consumptions that have been made following the instructions indicated below.

Press key T5 (of 1st unit only) and keep pressed for over 10 seconds. The display will show the dispensing operations undertaken : press key T5 again to escape from this condition.

By pressing key T1 (forward) or T2 (back) it is possible to consult the various memorized consumption values.

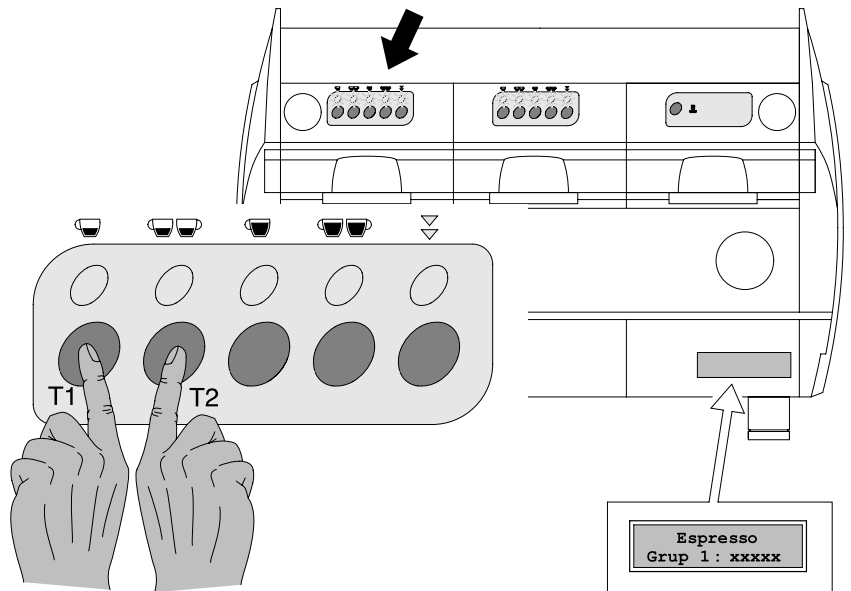
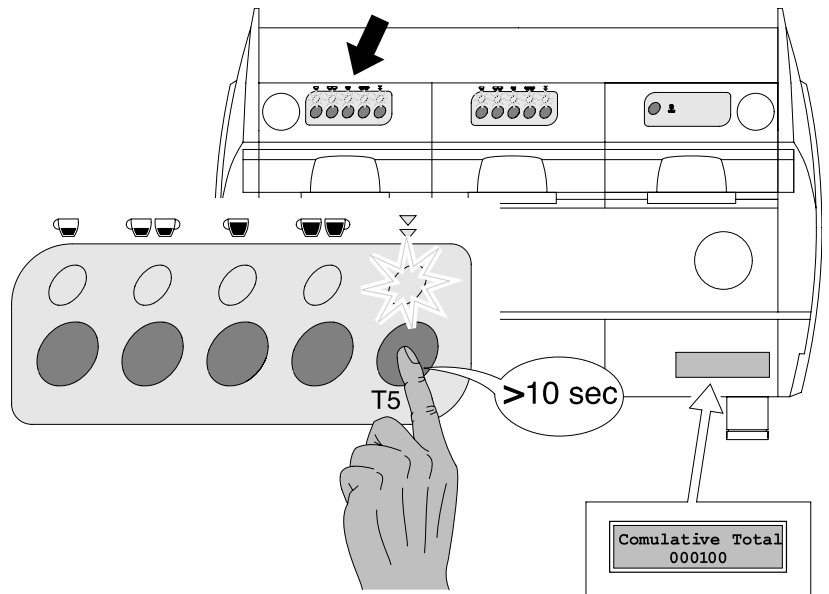

On pressing key T1 of unit 1 on goes on to the consumption values of the keys of unit 2 and so on in succession.

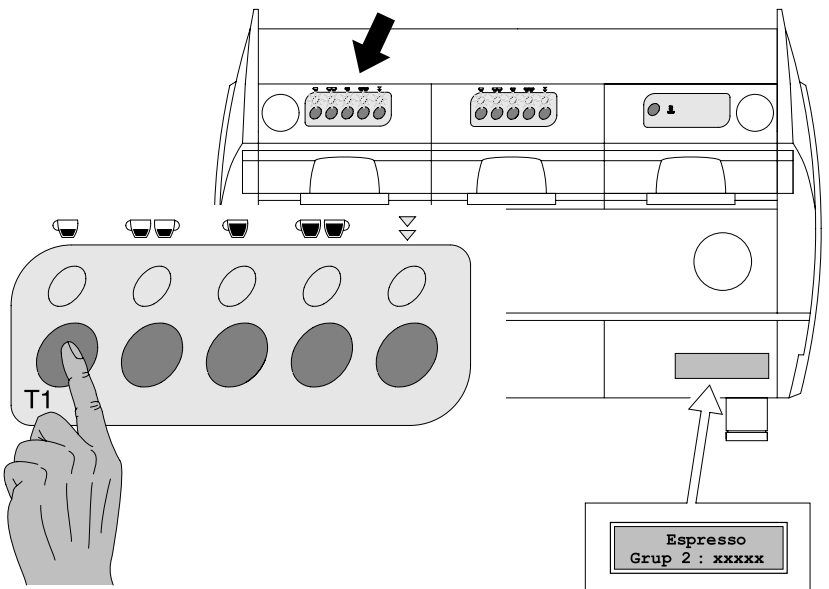

After visualization of the data of the last coffee unit also, on pressing key T1 it is possible to obtain a reading of the number of TEA dispensing operations made.

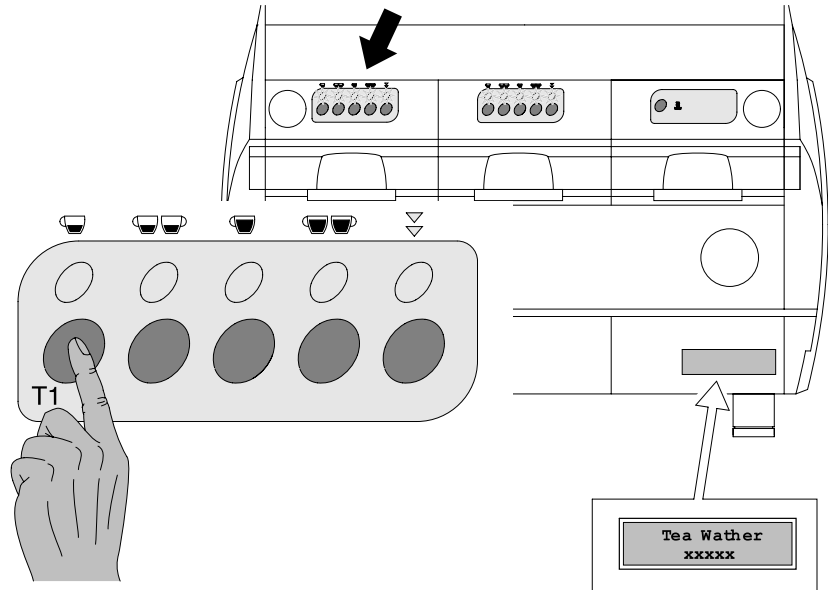

To cancel the totals of the individual consumptions (but not the "total cumulative" data), press keys T3 and T4 of unit 1 for 3 seconds in the condition in which "CUMULATIVE TOTAL" is displayed.

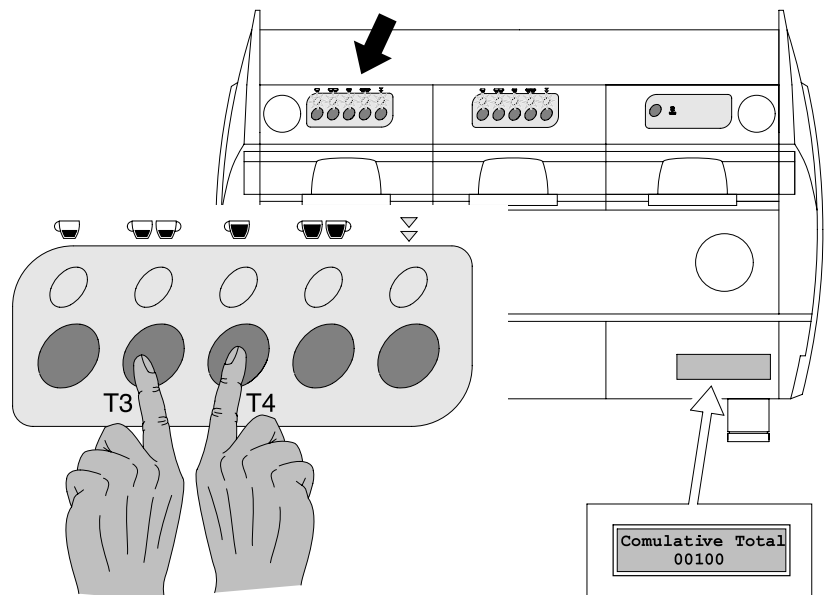

7.11 Alarm condition

Boiler (filling) level time out

This alarm condition occurs whenever the water level is too low or the level probe remains uncovered. In such a case the keyboard leds flash and an alarm message appears on the display.

The filling stage is automatically engaged and to cancel the alarm conditions switch the machine off and then on again.

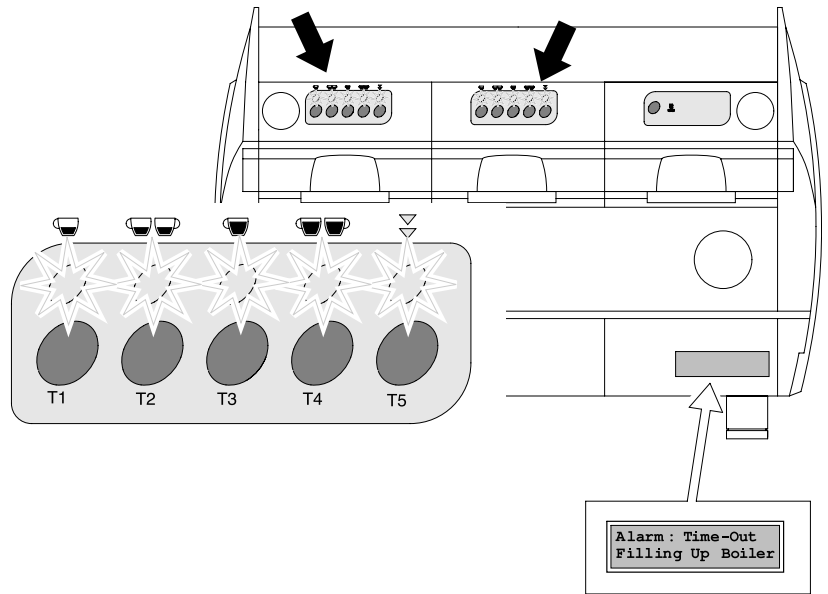

Lack of volumetric counter impulses

On starting a volumetric control coffee cycle, the correct function of the volumetric counter is checked by the reading of the number of impulses sent by the same to the micro-controller.

Should no impulses be recorded for a period exceeding 5 seconds the LED relative to the selected measure begins flashing (ie. the led relative to key T4).

After one minute in which no impulses are recorded (volumetric counter time out), the measure underway is automatically stopped.

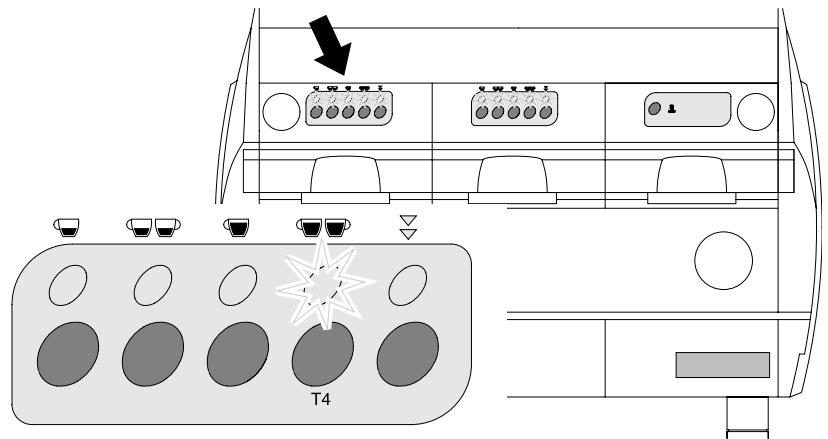

8 - PURIFIER REGENERATION

Fig. 8.01

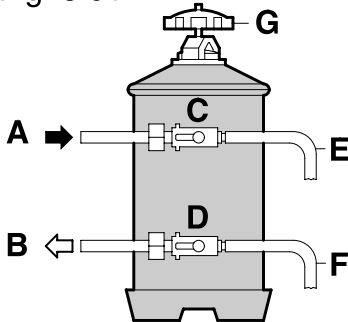

Fig. 8.02

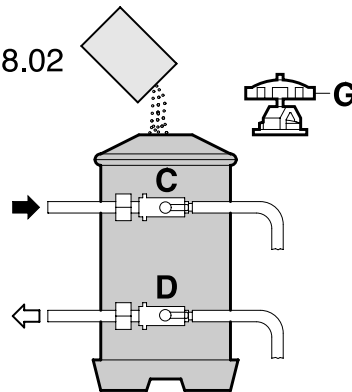

Fig. 8.03

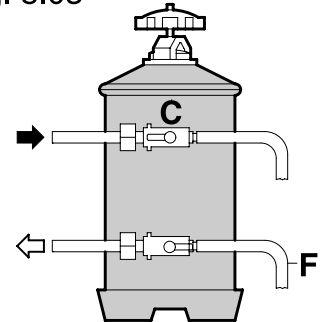
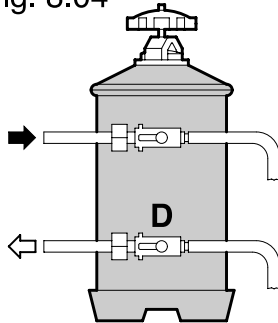

Fig. 8.04



- A WATER INLET
- B WATER OUTPUT
- C INLET TAP LEVER
- D OUTPUT TAP LEVER
- E DEPRESSURIZER PIPE
- F REGENERATION TUBE
- G COVER KNOB

! **IMPORTANT** : Regenerate the purifier at the intervals listed below:

HARDNESS ° F

8 LITRE PURIFIER

- From 00 to 20 regeneration after 1100 l.
- From 21 to 30 regeneration after 850 l.
- From 31 to 40 regeneration after 650 l.
- From 41 to 60 regeneration after 450 l.

12 LITRE PURIFIER

- regeneration after 1600 l.
- regeneration after 1250 l.
- regeneration after 950 l.
- regeneration after 650 l.

- place the empty 2 litre container under pipe E.
- shift levers C and D from left to right as shown in fig.8.2 and remove the cover by loosening knob G, pour in 1.5 kg of sodium chloride (coarse cooking salt) into the 8-litre purifier and 2 kg into the 12-litre type.
- Replace the lid and shift lever from right to left as shown in fig.8.3 and allow the salted water to drain out of pipe F until the water is fresh.
- Shift lever D from right to left as shown in fig.8.4



NB: These regeneration instructions are valid only providing the purifier is as that indicated in the figures. Should it fail to correspond proceed as indicated in the instructions attached to the purifier itself.

9 - MAINTENANCE AND USEFUL ADVICE



In order to ensure that the spouts (B) are kept clean and free of any coffee deposits which may jeopardize yield, we advise that before starting work in the morning that you put filter holder (D) in with empty filter (while machine is hot) and operate the unit several times.

In this way any coffee dust which may have been deposited between the metal filter (B) and the metal filter holder (A) are removed. This operation must be repeated every day.

Frequently check the filter holes (C) and remove any deposits.

Should the water have been left in the ducts for a long time, it is necessary to allow some water to flow through them in order to remove any deposits.

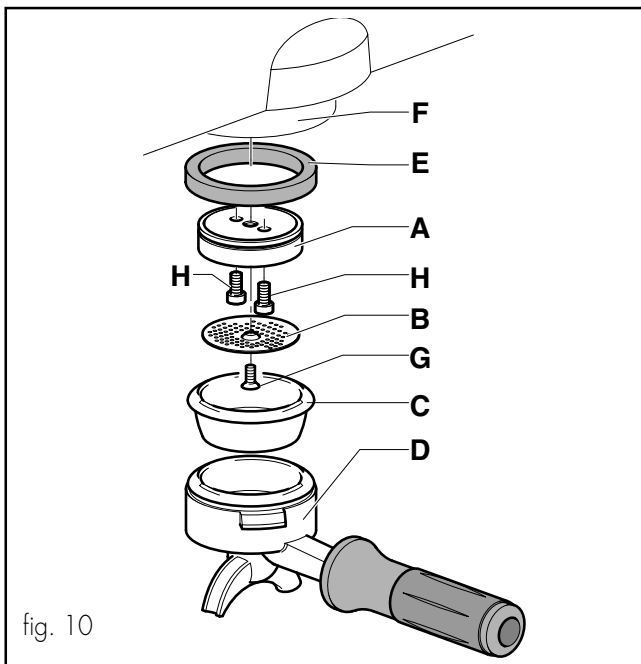

- A SPOUT HOLDER
- B SPOUT
- C FILTER
- D FILTER HOLDER
- E SEAL
- F COFFEE GROUP
- G CENTRAL SCREW
- H SCREW

It is a good idea to rinse the filters (C) and filter holders (D) every day in hot water, or even better, place them in hot water and allow to soak for the whole night in order to dissolve any greasy coffee deposits.

It is advisable to leave the filter-holder cups inserted with the coffee dregs for the entire working day to ensure that the filter-holder is always at optimum temperature.

Do not cover the cup-warmer level with any fabrics or cloths etc.

Do not use any abrasive or corrosive products for cleaning the bodywork.

The steam nozzles must be cleaned immediately after use in order to prevent the risk of the formation of any scale which may block the holes and to ensure that any drinks made subsequently do not absorb any unpleasant odours.

Weekly cleaning operations

Cleaning of the unit and spouts: place a teaspoon of specific coffee machine washing powder into the blind filter supplied with the machine and apply to the unit to be cleaned using the filter-holder. Press the unit delivery control button as for a normal coffee dispensing operation. Suspend delivery after 30 seconds and then repeat the operation 3-4 times. Rinse out the unit using a normal filter and then undertake a few dispensing operations using water only. Then prepare a coffee in order to eliminate any unpleasant odours.



Below-cup seal replacement

Seal (E) needs to be replaced in the event that coffee leakage is noted between unit (F) and filter-holder (G), or in the event that on closing filter holder (D) the unit centre is greatly exceeded.

Remove the spout (B) by loosening the central screw (G). Remove the spout holder (A) by loosening the two Allen screws (H).

Then proceed to remove seal (E) using a screw driver. After removing the seal undertake to clean the slot and then re-assemble the new seal taking care to insert it with the chamfered part turned upwards towards the unit itself.

10 - TROUBLE SHOOTING

PROBLEM	CAUSE	REMEDY
Machine switch off	<ol style="list-style-type: none"> 1. Mains switch off 2. Machine switch off 3. Incorrect electrical mains connection 	<ol style="list-style-type: none"> 1. position the machine switch to position ON 2. position the machine switch to position 1 3. contact specialized personnel in order to check the connection
No water in boiler	<ol style="list-style-type: none"> 1. Mains tap closed 2. Clogged pump filter 3. Motor driven pump not in operation 	<ol style="list-style-type: none"> 1. open the mains tap 2. replace the filter 3. contact specialized personnel
No unit delivery	<ol style="list-style-type: none"> 1. mains tap closed 2. motor driven pump out of order 3. clogged gicleur 4. burnt control box fuse 5. unit solenoid valve out of order 6. unit switch out of order 	<ol style="list-style-type: none"> 1. open the mains tap 2. contact specialized personnel 3. contact specialized personnel 4. contact specialized personnel 5. contact specialized personnel 6. contact specialized personnel
Steam fails to come out of the nozzle	<ol style="list-style-type: none"> 1. too much water in boiler 2. damaged resistance 3. clogged sprayer element 4. resistance saver engaged 	<ol style="list-style-type: none"> 1. see specific problem 2. contact specialized personnel 3. clean the sprayer element 4. reinsert the resistance
Too much water in the boiler	<ol style="list-style-type: none"> 1. the motor driven pump remains engaged 2. perforated exchanger 3. automatic charge solenoid valve blocked 	<ol style="list-style-type: none"> 1. contact specialized personnel 2. contact specialized personnel 3. contact specialized personnel
Signs of water leakage on bench	<ol style="list-style-type: none"> 1. dirty drain tray 2. drainage pipe clogged or detached 3. other leakage 	<ol style="list-style-type: none"> 1. clean the try 2. replace the drainage pipe 3. contact specialized personnel
Wet coffee dregs	<ol style="list-style-type: none"> 1. Grinding regulated too fine 2. Unit still cold 3. Solenoid valve fails to discharge 	<ol style="list-style-type: none"> 1. Adjust grinding value 2. wait for the machine to reach the correct temperature 3. contact specialized personnel
Coffee dispensing too slow	<ol style="list-style-type: none"> 1. grinding element set too fine 2. dirty filter-holder 3. clogged unit 4. gicleur or solenoid valve partially clogged 	<ol style="list-style-type: none"> 1. Adjust the grinder 2. replace the filter and undertake more frequent filter-holder cleaning 3. contact specialized personnel 4. contact specialized personnel
Coffee dispensing too fast	<ol style="list-style-type: none"> 1. grinder is regulated too large 	<ol style="list-style-type: none"> 1. regulate the grinding
Coffee delivered cold	<ol style="list-style-type: none"> 1. Lime scale present on the exchangers or the resistances 2. oxidized pressure switch contacts 3. defective electrical connection 4. partially burnt out resistance 	<ol style="list-style-type: none"> 1. contact specialized personnel 2. contact specialized personnel 3. contact specialized personnel 4. replace the resistance element
Coffee delivered too hot	<ol style="list-style-type: none"> 1. incorrect pressure switch calibration 	<ol style="list-style-type: none"> 1. regulate the pressure switch by means of the relative screw (chap. 6.2)

11 - MACHINE DISMANTLING

To dismantle the machine we recommend that it is dismantled and the parts separated according to the type of materials involved (plastic, metal, etc). The parts separated in this way are then to be sent to the relative specialized disposal company.

LEGENDA COMPONENTI - COMPONENTS LIST - LEGENDE BAUTEILE
LEGENDE DES COMPOSANTS- LEYENDA COMPONENTES

1	Cavo alimentazione pentapolare	penta-polar power cable	Fünfpoliges Stromversorgungskabel	Câble d'alimentation pentapolaire	Cable alimentació n pentapolar
2	Cavo alimentazione tripolare	three-pole power cable	Dreipoliges Stromversorgungskabel	Câble d'alimentation tripolaire	Cable alimentació n tripolar
3	Commutatore 4 posizioni	4-position commutator	4-stelliger Umschalter	Commutateur à 4 positions	Conmutador 4 posiciones
4	Pressostato tripolare	three-pole pressure switch	Dreipoliger Druckwä hler	Pressostat tripolaire	Presó stato tripolar
5	Morsettiera di derivazione	branch terminal board	Verteilerklemmleiste	Boî te de dérivation	Tablero de bornes de derivació n
6	Resistenza caldaia	boiler resistance	Heizwiderstand	Résistance de la chaudière	Resistencia caldera
7	Resistenza scaldatazze	cup-warmer resistance	Heizelement zur Tassenwär mung	Résistance du chauffe-tasses	Resistencia calienta-tazas
8	Termostato a riarmo manuale	manual re-set thermostat	Thermostat zur manuellen Rücksetzung	Thermostat à réarmement manuel	Termostato de rearme manual
9	Spia rossa macchina accesa	machine on - red light indicator	Rote Kontrolleuchte Maschine in Betrieb	Témoin rouge machine allumée	Luz de aviso roja máquina encendida
10	Interruttore scaldatazze	cup warmer switch	Schalter Tassenwär mer	Interrupteur du chauffe-tasses	Interruptor calienta-tazas
11	Spia interruttore caffè	light indicator coffee switch	Kontrolleuchte Schalter Kaffee	Témoin interrupteur du café	Luz de aviso interruptor café
12	Interruttore caffè	coffee switch	Schalter Kaffee	Interrupteur du café	Interruptor café
13	Elettrovalvola gruppo	unit solenoid valve	Magnetventil Gruppe	É lectrovanne du groupe	Electrová vula grupo
14	Elettrovalvola livello automatico	automatic level solenoid valve	Magnetventil automatischer Füllstand	É lectrovanne de niveau automatique	Electrová vula nivel automático
15	Elettrovalvola prelievo acqua calda	Hot water collection solenoid valve	Magnetventil Heißwasserentnahme	É lectrovanne de prélèvement d'eau chaude	Electrová vula toma de agua caliente
16	Elettrovalvola prelievo latte	Milk collection solenoid valve	Magnetventil Milchentnahme	É lectrovanne de prélèvement de lait	Electrová vula toma de leche
17	Motopompa completa	Complete motor driven pump	Motorpumpe komplett	Pompe complète	Motobomba completa
18	Centralina controllo livello automatico	automatic level control box	Steuergehä use automatische Füllstandkontrolle	Centrale contrôle niveau automatique	Central control nivel automático
19	Sonda livello automatico	automatic level probe	Sonde automatischer Füllstand	Sonde de niveau automatique	Sonda nivel automático
20	Interruttore prelievo acqua calda	hot water collection switch	Schalter Heißwasserentnahme	Interrupteur de prélèvement d'eau chaude	Interruptor toma de agua caliente
21	Interruttore prelievo acqua calda	hot water collection switch	Schalter Heißwasserentnahme	Interrupteur de prélèvement d'eau chaude	Interruptor toma de agua caliente
22	Resistenza a cartuccia	cartridge resistance	Kartuschenwiderstand	Résistance à cartouche	Resistencia de cartucho
23	Termostato gruppo	unit thermostat	Thermostat Gruppe	Thermostat du groupe	Termostato grupo
24	Relè prelievo acqua calda	hot water collection relay	Relais Heißwasserentnahme	Relais de prélèvement d'eau chaude	Relé toma de agua caliente
25	Tastiera dosatura volumetrica	volumetric measuring keyboard	Tastatur Volumendosierung	Clavier de dosage volumétrique	Teclado dosificació n volumétrica
26	Centralina elettronica dosatura volumetrica	volumetric measuring electronic control box	Elektronisches Steuergehä use Volumendosierung	Centrale électronique du dosage volumétrique	Central electrónica dosificació n volumétrica
27	Contatore volumetrico	volumetric counter	Volumenmesser	Compteur volumétrique	Contador volumétrico
28	Pulsante prelievo acqua calda	hot water collection button	Taste Heißwasserentnahme	Bouton-poussoir de prélèvement d'eau chaude	Botón toma de agua caliente
29	Display	display	Display	É cran	Display

AROMA SM-SE 2-3-4 GR. CIRCUITO DI POTENZA HIGH CURRENT SECTION OF THE ELECTRICAL CIRCUIT

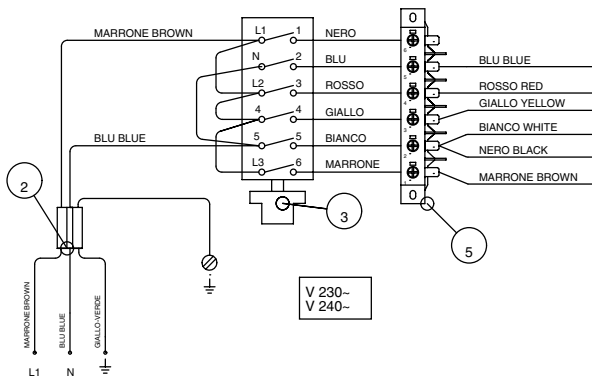
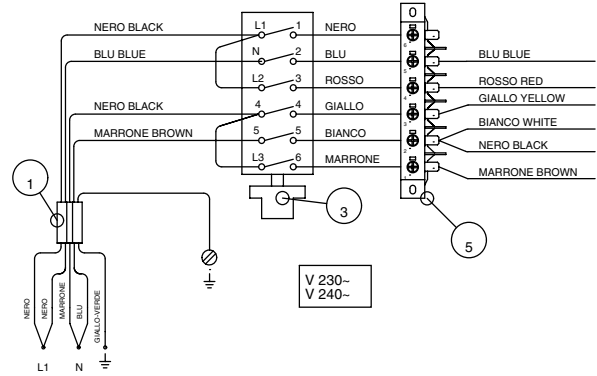
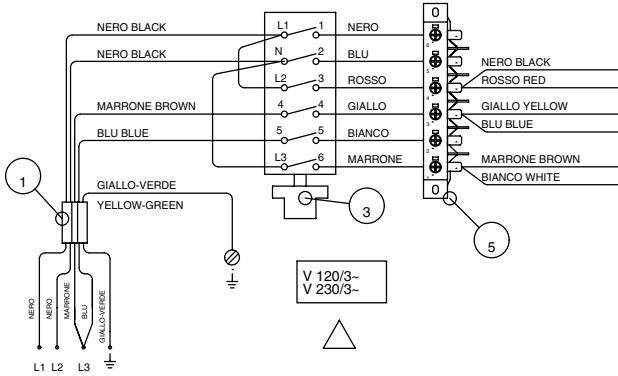
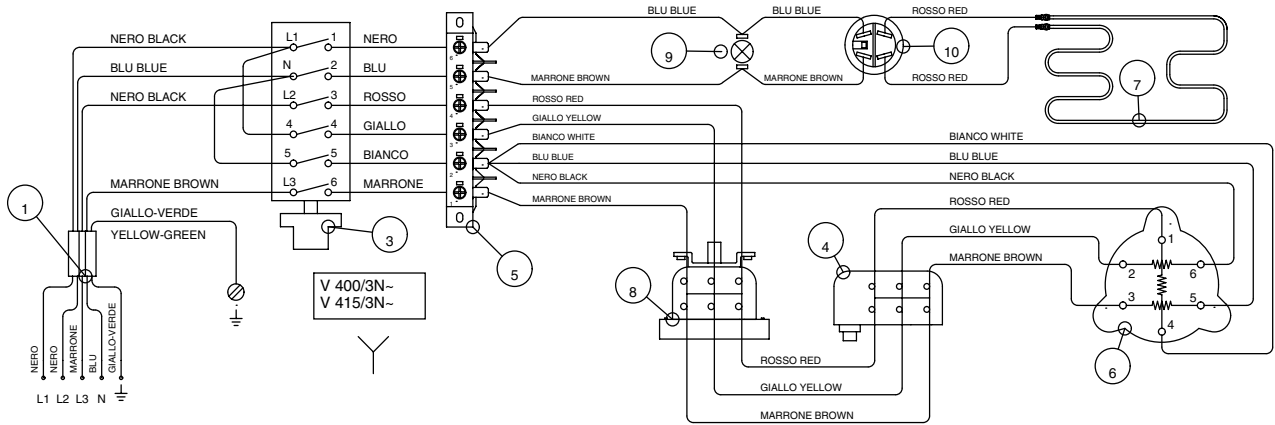

SAE0400 Rev0

AROMA SM 2GR. CIRCUITO DI COMANDI CONTROL SECTION OF THE ELECTRICAL CIRCUIT

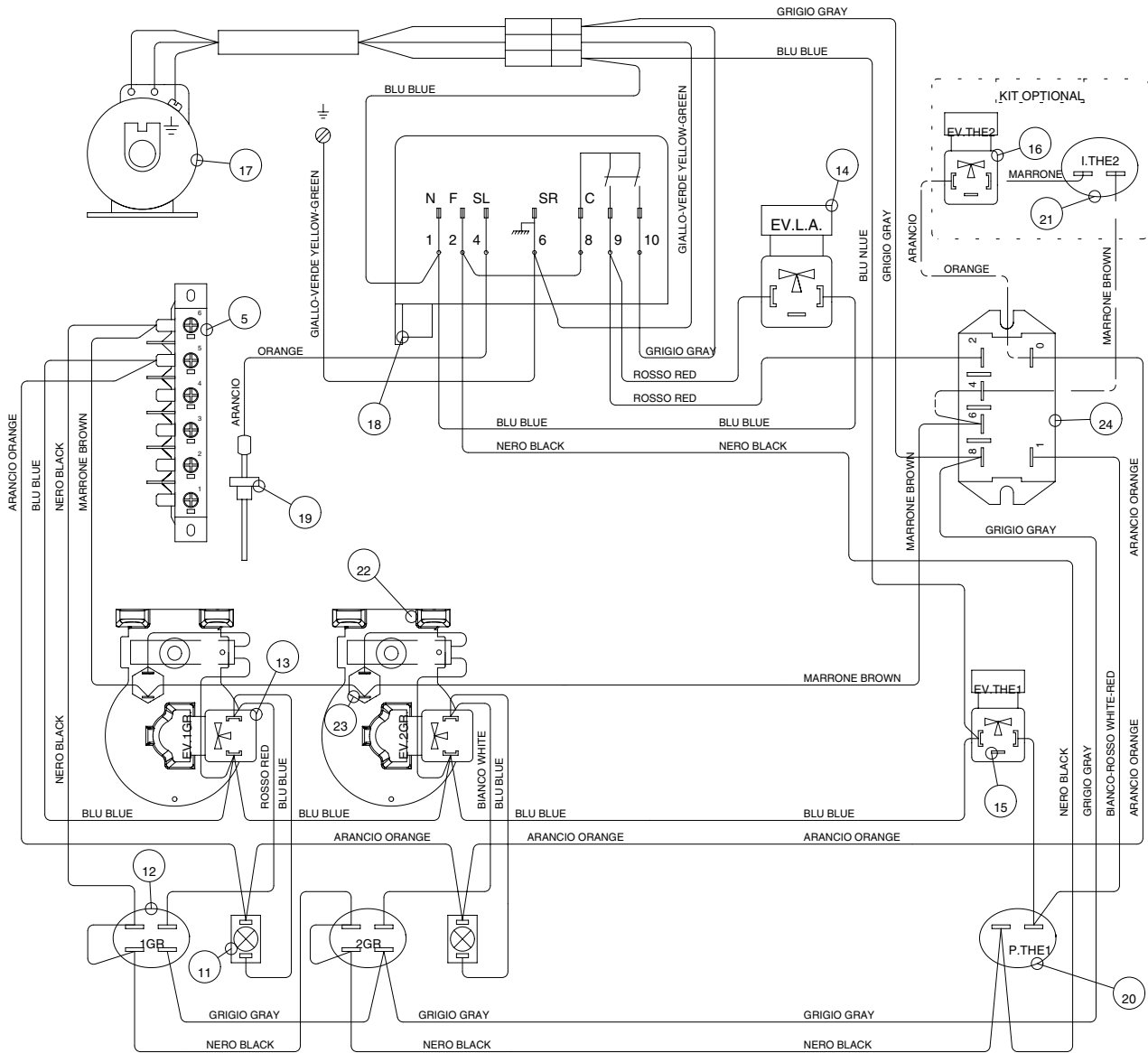

AROMA SM 3GR.
CIRCUITO DI COMANDI
CONTROL SECTION OF THE ELECTRICAL CIRCUIT

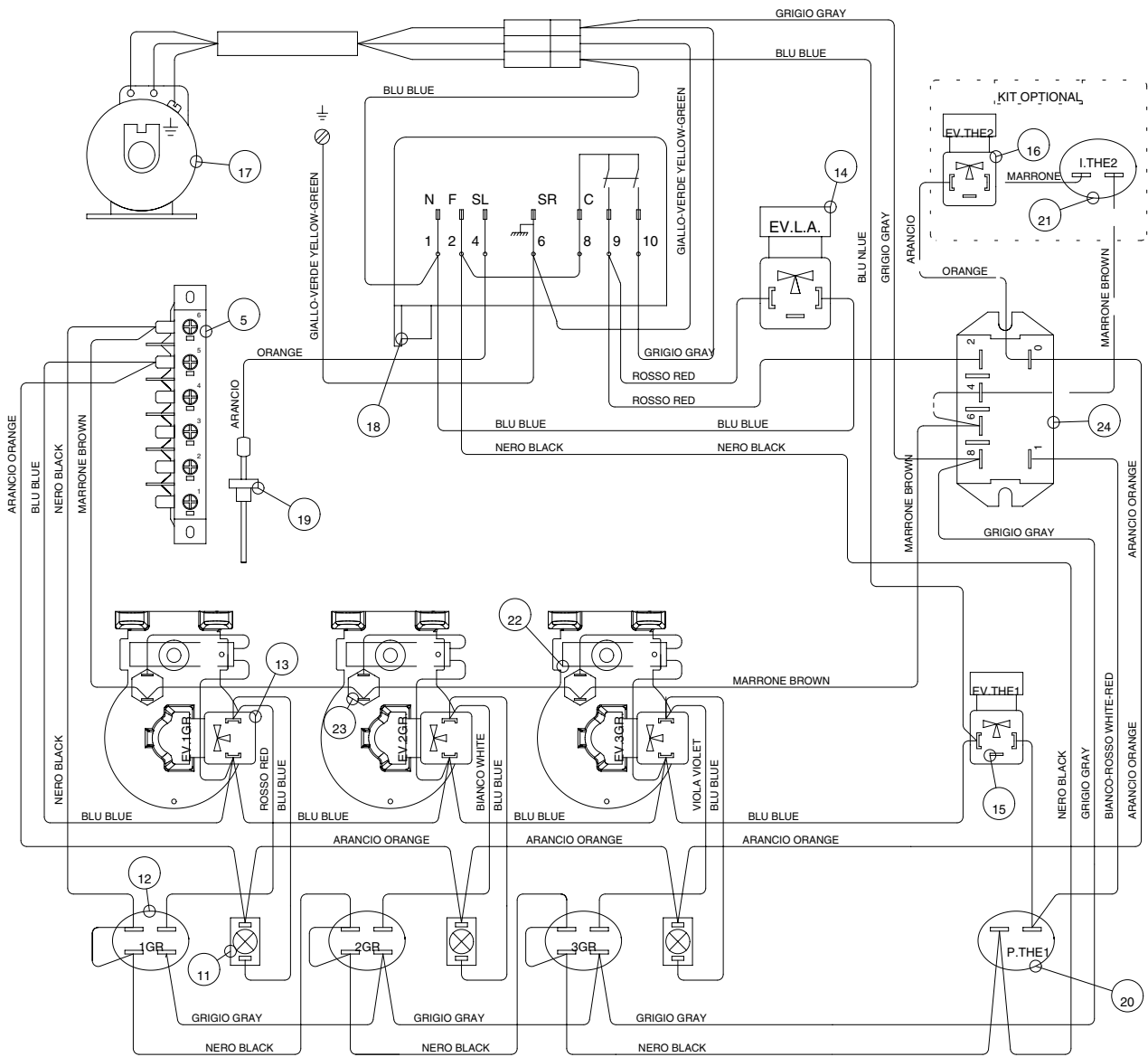

**AROMA SM 4GR.
CIRCUITO DI COMANDI
CONTROL SECTION OF THE ELECTRICAL CIRCUIT**

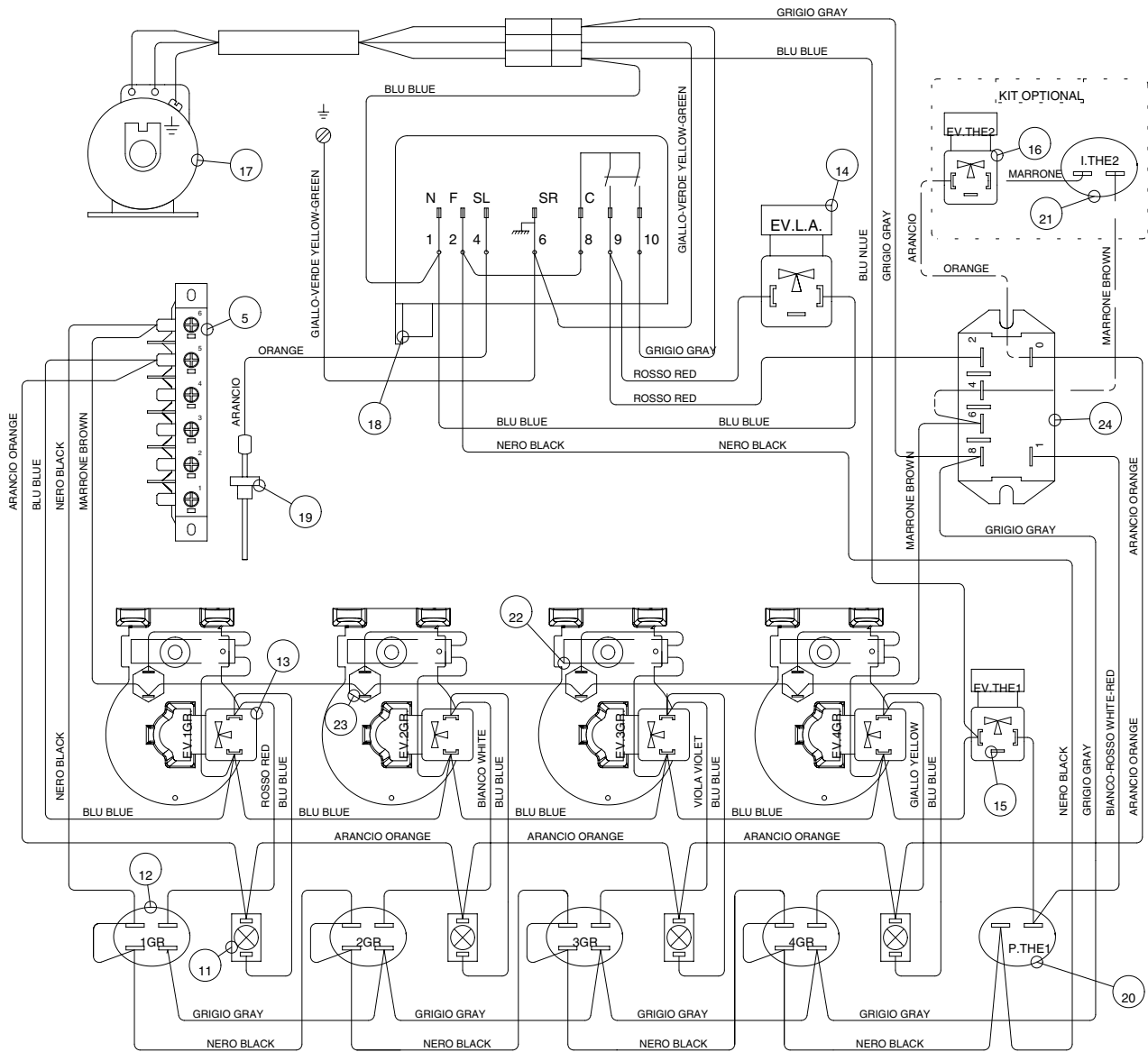

**AROMA SE 2GR.
CIRCUITO DI COMANDI
CONTROL SECTION OF THE ELECTRICAL CIRCUIT**

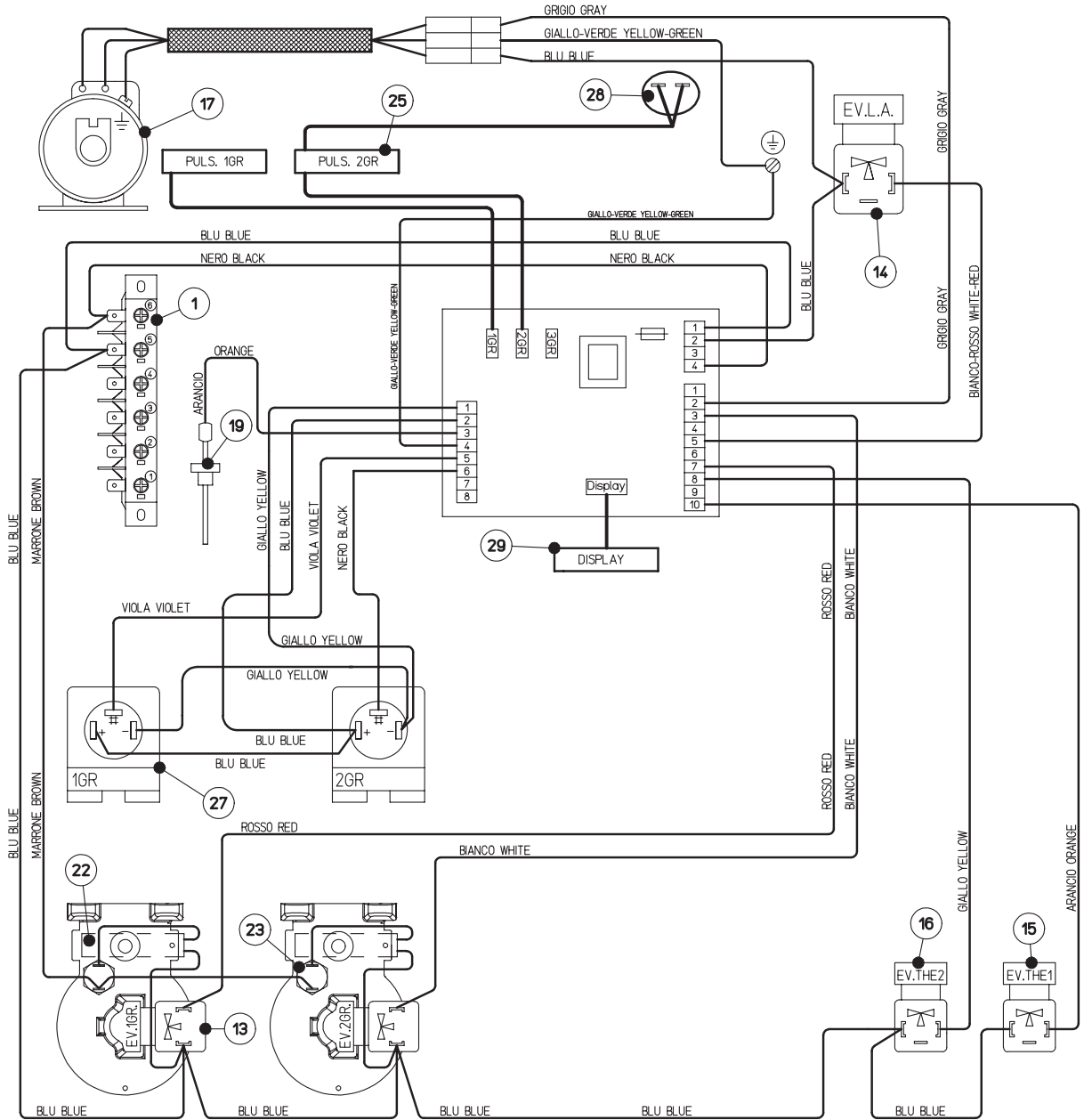

**AROMA SE 3GR.
CIRCUITO DI COMANDI
CONTROL SECTION OF THE ELECTRICAL CIRCUIT**

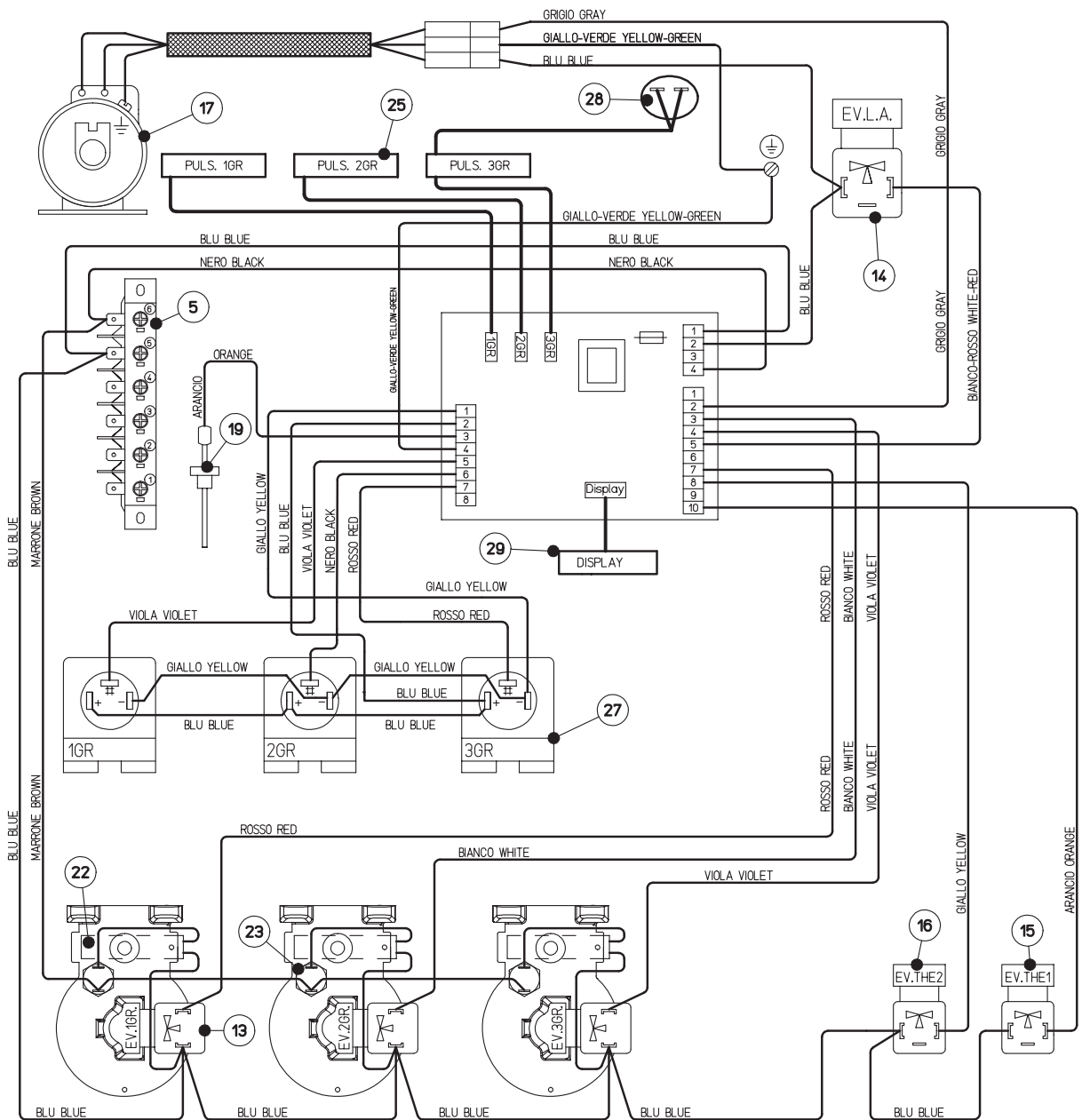

AROMA SE 4GR. CIRCUITO DI COMANDI CONTROL SECTION OF THE ELECTRICAL CIRCUIT

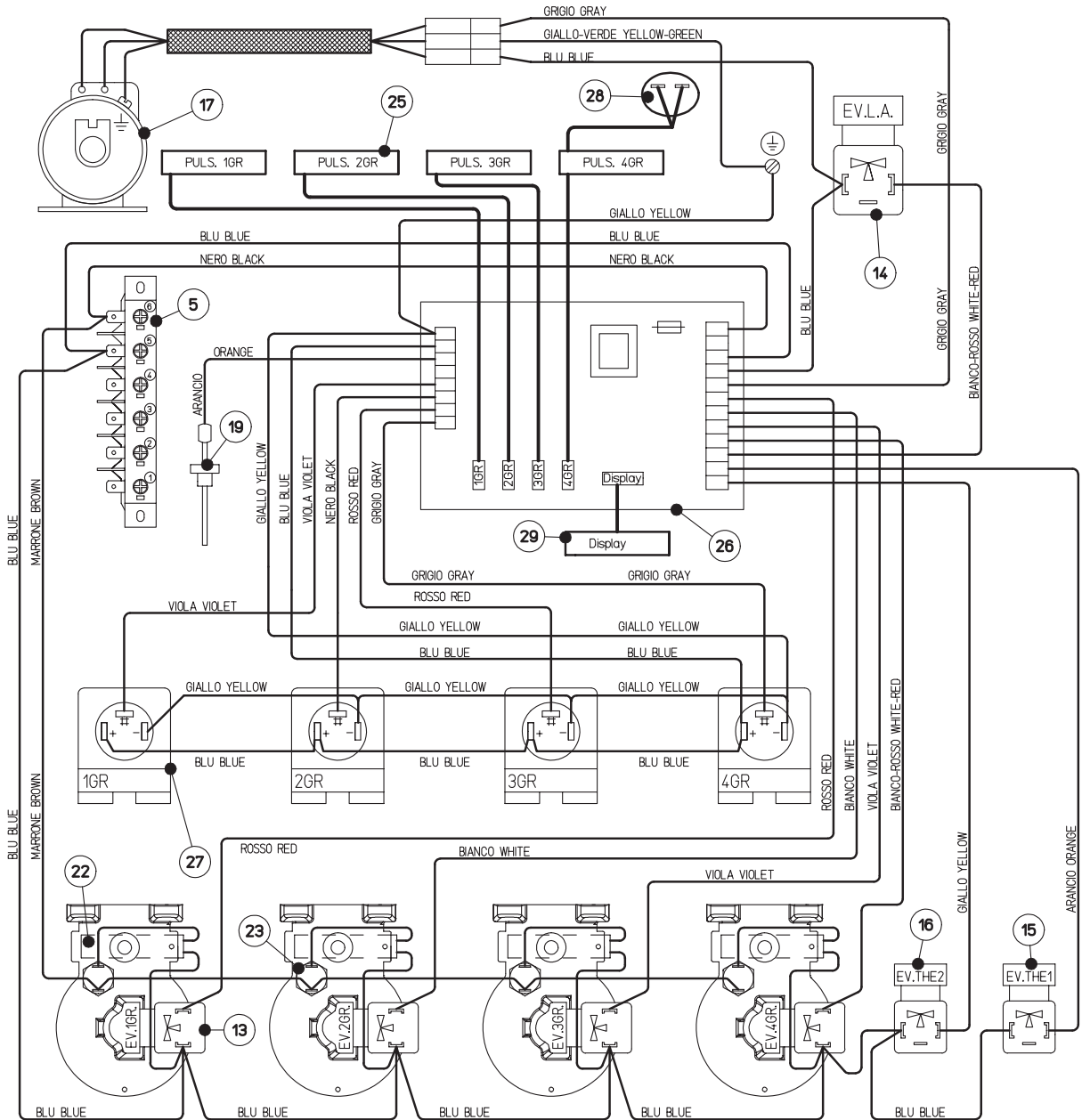

ELECTRICAL CONNECTION

Before connecting the machine to the power point, make sure that the rating corresponds with the one indicated on the rating-plate of the power cord.

Normally, the machines are preset for a star connection with earthed centre point.

V415 - 400 3N~

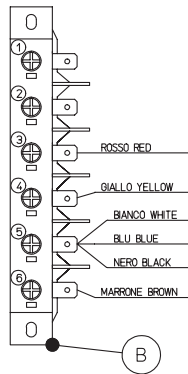
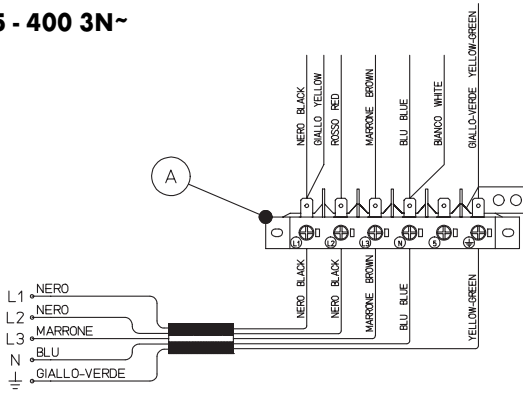

STANDARD Connection

Star connection with earthed centre point.

V240 - 230 3~

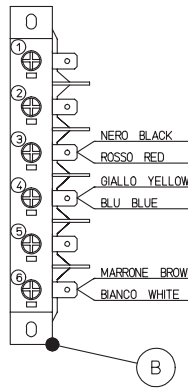
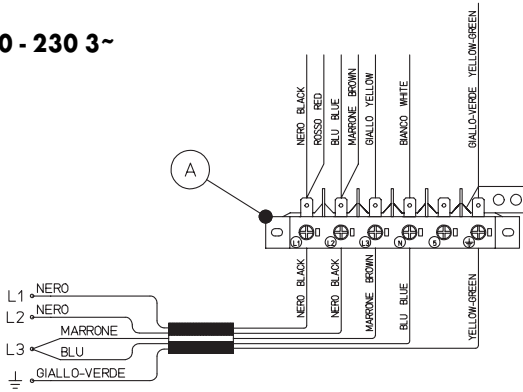

Delta connection

To change the connection from a star connection to a delta connection, modify the connections shown in the diagram (beside) on the power cord, the input terminal board (A), and the branching terminal board (B).

V240 - 230 ~

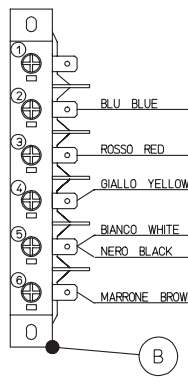
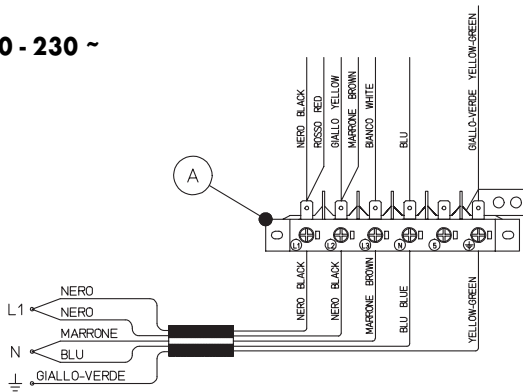

Single-Phase connection

To change the connection from a star connection to a single-phase connection, modify the connections shown in the diagram (beside) on the power cord, the input terminal board (A), and the branching terminal board (B).

V240 - 230 ~

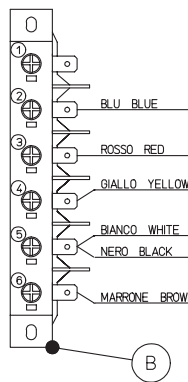
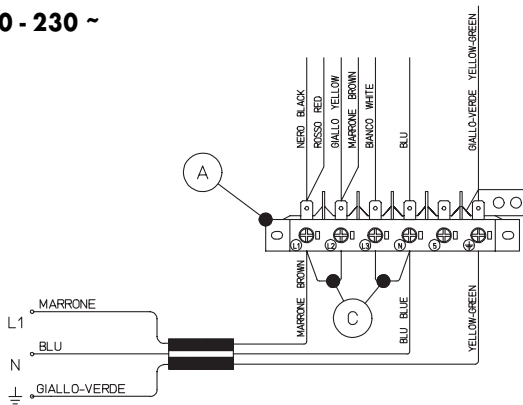

Single-Phase Connection with Three-Core Power Cord

To change the connection from a three-phase connection to a single-phase star connection, change the power cord and replace it with a three-core power cord of the HO7RN-F 3x4 mm² type (SJO 3x10 AWG for machines used in the USA). Add the supplied two jumpers (C) to the input terminal board (A) and modify the connections on the input terminal board (A) and on the branching terminal board (B) as shown in the diagram (beside).

