



S, SV, SVi, NGF, & Quickdraw™ Beverage/Ice Dispensers

Installation, Operation and Maintenance Manual

Original Instructions — This manual is updated as new information and models are released. Visit our website for the latest manual. www.manitowocbeverage.com/us



Safety Notices

As you work on Manitowoc equipment, be sure to pay close attention to the safety notices in this manual. Disregarding the notices may lead to serious injury and/or damage to the equipment.

Throughout this manual, you will see the following types of safety notices:

Warning

Text in a Warning box alerts you to a potential personal injury situation. Be sure to read the Warning statement before proceeding, and work carefully.

Caution

Text in a Caution box alerts you to a situation in which you could damage the equipment. Be sure to read the Caution statement before proceeding, and work carefully.

Procedural Notices

As you work on Manitowoc equipment, be sure to read the procedural notices in this manual. These notices supply helpful information which may assist you as you work.

Throughout this manual, you will see the following types of procedural notices:

Important

Text in an Important box provides you with information that may help you perform a procedure more efficiently. Disregarding this information will not cause damage or injury, but it may slow you down as you work.

NOTE: Text set off as a Note provides you with simple, but useful, extra information about the procedure you are performing.

Read These Before Proceeding

Warning

PERSONAL INJURY POTENTIAL

Do not operate equipment that has been misused, abused, neglected, damaged, or altered/modified from that of original manufactured specifications.

Warning

The installer is responsible to provide a suitable plug meeting all requirements, or a means for disconnection must be incorporated in the wiring according to the wiring rules.

Warning

This appliance is intended to be used indoors in kitchens or back rooms of food/restaurant establishments.

Warning

This appliance is not intended for use by persons (including children) with reduced physical, sensory or mental capabilities, or lack of experience and knowledge, unless they have been given supervision concerning use of the appliance by a person responsible for their safety. Do not allow children to play with this appliance.

Caution

Proper installation, care and maintenance are essential for maximum performance and trouble-free operation of your Manitowoc equipment. Read and understand this manual. It contains valuable care and maintenance information. If you encounter problems not covered by this manual, do not proceed, contact Manitowoc Foodservice Group.

Important

Routine adjustments and maintenance procedures outlined in this manual are not covered by the warranty.

Table of Contents

Section 1 General Information

Read This Manual	5
Unit Inspection	5
Serial Number Location	5
Warranty Information	5
Model Numbers	5
How to Read a Model Number	5
Accessories	6
Variety Valves	6
Flavor Magic™ Drink Enhancement System.....	6
Brix & Ratio Cups.....	6
Quality Assurance Kit	6
Beverage System Cleaner	6
Cup Dispensers	6
Cold Carbonation Retro-Fit Kit	6
Legs	6
Baffle for Manitowoc® Ice Machines	6
Manual Fill Lid	6
Ice Flow Restrictor	6

Section 2 Installation

General	7
Dimensions	7
Max Noise dB(A)	7
Footprints	8
Location	9
Ways Equipment Should Not be Used	9
Location Requirements for Top Mounted Ice Machine Installations	10
Pre-installation Checklist	10
Assembly	11
Installing Baffle for Ice Machine Installations.....	11
Electrical	12
General	12
Minimum Circuit Ampacity.....	12
Electrical Requirements	12
Voltage	12
Minimum Circuit Amperage Chart.....	12
Grounding Instructions.....	12
Pump Deck Wiring	13
Water Supply	14
Recommended Plumbing	14
S/SV150 6 Valve Diagram	15
S/SV175 8 Valve Diagram	16
S/SV200/250/SV-250QD 8 Valve Diagram	17
S/SV200/250 10 Valve Diagram	18
NGF-250 & NGF-250QD 8 Valve Diagram	19
CO₂ Supply	20
Routing Internal Carb Tank Purge Tube.....	20
Drains	20
Step by Step Installation	21
General	21
Specifications Chart.....	21

Unit Installation..... 21
 Quickdraw Installations..... 22
 Setting Pressures 22
 ADA Key Pads 23
 Starting Your Beverage System & Dispenser 24

**Section 3
 Operation**

General System Overview 25
Component Identification 26
Sequence of Operation 26
 Ice Recommended for Dispensing..... 26
 Ice Storage and Dispensing..... 26
 Beverage Valves 26
 Rocking Chute Ice Dispensing..... 26
 Carbonation 27
 Syrup Delivery System..... 27
 Back Room Package 27
 Racking..... 28
 B-I-B 28
 Pumps..... 28
 Auto Bag Selectors..... 28
 Figal System 28
 Figal Tanks..... 28
 Agitation Timer..... 28
Operation Checks and Adjustments 29
 Rocking Chute Ice Delivery Switch Adjustment..... 29
 Quickdraw Ice Portion Adjustments..... 30
 Sensor Beam 31
 Brix Check..... 32

**Section 4
 Maintenance**

Cleaning & Sanitizing..... 33
 General..... 33
 Daily Cleaning..... 33
 Cleaning Checklist 34
Preventative Maintenance 35
Disassembly..... 35
 Disassembly for Cleaning & Maintenance..... 35
 Disassemble the Rocking Chute 36
 Quickdraw Components..... 37
 Non-front Serviceable Gear Motor Removal 38
 Front Serviceable Gear Motor Removal 39
Sanitizing 40
 Beverage System Cleaning 40
 Bag-In-Box System Sanitation 40
 Figal Beverage System..... 41
Shipping, Storage and Relocation 41

**Section 5
 Troubleshooting**

Checklist..... 43
Drink Troubleshooting..... 44
Pump Troubleshooting 45
Quickdraw Mechanism Troubleshooting 45
Quickdraw Ice Portion Control Program 46

Section 1

General Information

Read This Manual

Manitowoc Beverage Equipment (MBE) developed this manual as a reference guide for the owner/operator and installer of this equipment. Please read this manual before installation or operation of the machine. A qualified service technician must perform installation and start-up of this equipment, consult Section 5 within this manual for service assistance.

If you cannot correct the service problem, call your MBE Service Agent or Distributor. Always have your model and serial number available when you call.

Your Service Agent _____

Service Agent Telephone Number _____

Your Local MBE Distributor _____

Distributor Telephone Number _____

Model Number _____

Serial Number _____

Installation Date _____

Unit Inspection

Thoroughly inspect the unit upon delivery. Immediately report any damage that occurred during transportation to the delivery carrier. Request a written inspection report from a claims inspector to document any necessary claim.

Serial Number Location

This number is required when requesting information from your local distributor. The serial number is listed on the SERIAL NUMBER DECAL affixed to the dispenser.

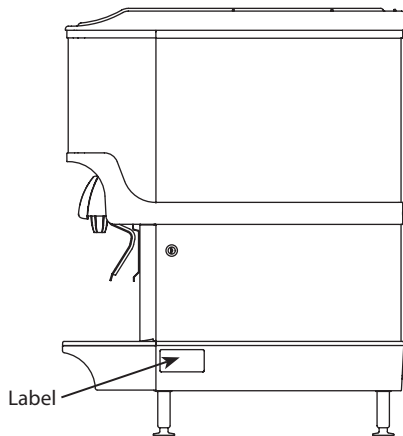

Serial Number Location

Warranty Information

Visit www.manitowocbeverage.com for:

- Warranty Verification
- Warranty Registration
- View and download a copy of your warranty

Model Numbers

This manual covers the following models:

Beverage/Ice Dispensers
S-150, S-200, S-250, SV-150, SV-175, SV-200, SV-250, SV-150i, SV-175i, SV-200i, SV-250i, SV-250QD, NGF-250, NGF-250QD

HOW TO READ A MODEL NUMBER

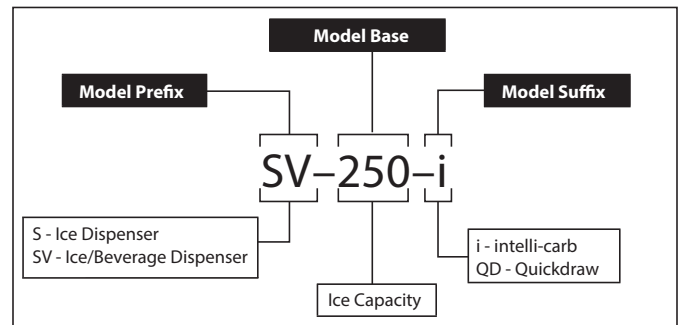

Accessories

VARIETY VALVES

Variety Valves are a great way of extending your beverage offerings with non-carbonated drinks without extending the dispenser footprint! The McCann's Variety Valve is available in Autofill, Self-Serve, Sanitary Lever and Portion Control.

FLAVOR MAGIC™ DRINK ENHANCEMENT SYSTEM

The Flavor Magic™ Drink Enhancement System allows you to offer your fountain beverage customers more flavor choices without using any additional counter space for custom drink combinations that drives return business!

BRIX & RATIO CUPS

Ensure that your customers get the best-tasting beverage! Over time, valves can fall out of their intended calibration. McCann's Brix and Ratio Cups help you to keep the syrup-to-water ratio correct, assuring a consistent, refreshing drink each time.

QUALITY ASSURANCE KIT

The tools required to test fountain drink quality are included in a single, compact, durable, and economic package.

BEVERAGE SYSTEM CLEANER

BevClean™ - No Rinse, Bag-In-Box Beverage System Cleaner. Scheduled cleaning is essential for a properly functioning beverage dispensing system. Get the peace of mind that comes with this easy-to-use cleaner that delivers a fresh, deposit-free system!

CUP DISPENSERS

Servend cup dispensers help keep your hot or cold drink serving area organized by giving a uniform appearance to the storage of cups and drink accessory items.

COLD CARBONATION RETRO-FIT KIT

Servend's new Cold Carbonation Retro-Fit Kit delivers cold water to the carbonator which results in higher carbonation levels, better-tasting drinks, and year-round, consistent water temperature to your fountain beverage center.

LEGS

Legs are optional equipment with most MBE dispensers. Standard legs are 4" (10.2 cm) tall stainless steel legs. If an ice machine is installed on top of the dispenser, legs must not be installed. We do not recommend using legs when an ice machine is mounted on the dispenser. The combined weight of the dispenser, ice and ice machine is more evenly distributed when the base area of the dispenser is in contact with the countertop.

BAFFLE FOR MANITOWOC® ICE MACHINES

When installing a Manitowoc Ice Machine on a dispenser, a baffle kit is required for proper installation. The baffle kit is designed to prevent ice from lying against the front of the ice machine, and melting down the front of the dispenser. There are two different baffle kits available for "S" series ice machines — one kit is for the 30" wide machine, and the other kit is for the 22" wide machine. There is also a kit for "Q" series ice machines.

Kits are available through your local distributor. List prices may be subject to change without notification. Please call your local parts distributor for current pricing before ordering.

NOTE: For full information about ice machine installation, including plumbing lines connections and electrical requirements, see the ice machine installation manual.

MANUAL FILL LID

If you are top mounting your dispenser with an ice machine, you will require a lid for the manual fill area at the top, front of the dispenser.

If you ordered a dispenser and an ice machine at the same time, the manual fill lid was included with the unit. The manual fill lid can be ordered from your local distributor.

ICE FLOW RESTRICTOR

An optional ice flow restrictor decreases the amount of ice allowed to enter the ice chute by blocking a small area at the entrance of the dispenser chute. This in turn restricts the flow of ice that is dispensed into your cup.

Please refer to the instructions included in kit #5013822 for more information on how to install.



Ice Flow Restrictor

Section 2 Installation

General

These instructions are provided to assist the qualified installer. Contact your Manitowoc Beverage Equipment Service Agent or call Manitowoc Beverage Equipment for information regarding start-up services.

The unit should be installed and serviced by a suitably trained person.

Important

Failure to follow these installation guidelines may affect warranty coverage.

Dimensions

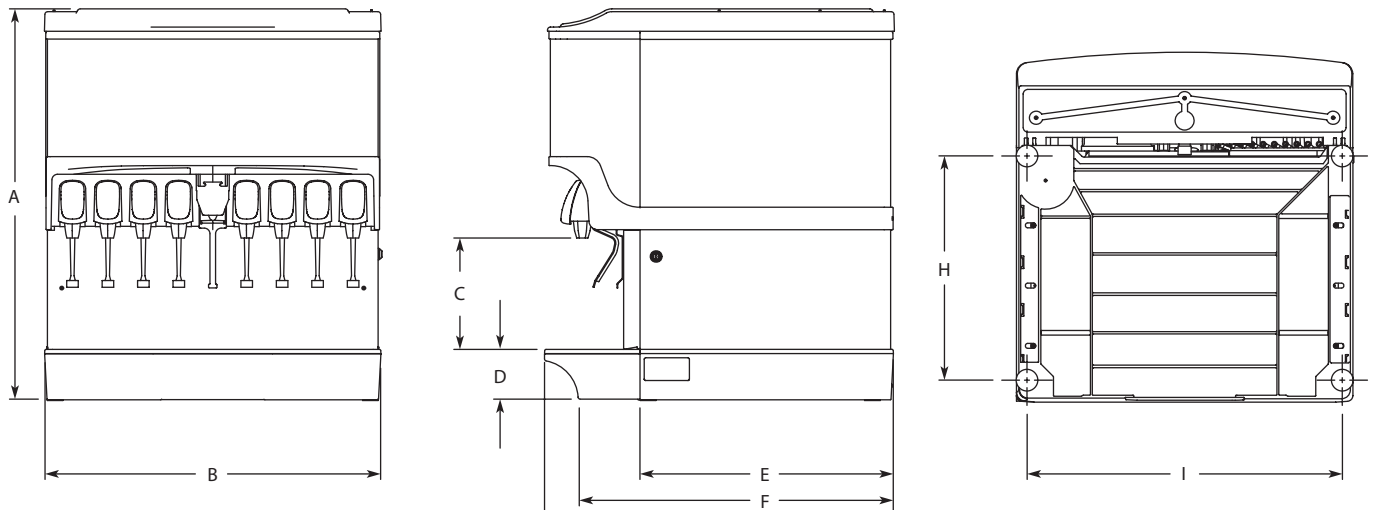

Model/Ice Capacity	A	B	C	D	E	F	G	H	I
S/SV-150	34.81" (88.4 cm)	23.00" (58.4 cm)	9.94" (17.6 cm)	4.44" (11.3 cm)	22.63" (57.5 cm)	28.00" (71.1 cm)	31.13" (79.1 cm)	20.00" (50.8 cm)	20.44" (51.9 cm)
S/SV-175	34.81" (88.4 cm)	25.00" (63.5 cm)	9.94" (17.6 cm)	4.44" (11.3 cm)	22.63" (57.5 cm)	28.00" (71.1 cm)	31.13" (79.1 cm)	20.00" (50.8 cm)	22.44" (57.0 cm)
S/SV-200	34.81" (88.4 cm)	30.00" (76.2 cm)	9.94" (17.6 cm)	4.44" (11.3 cm)	22.63" (57.5 cm)	28.00" (71.1 cm)	31.13" (79.1 cm)	20.00" (50.8 cm)	27.44" (69.7 cm)
S/SV/NGF-250	39.81" (101.1 cm)	30.00" (76.2 cm)	9.94" (17.6 cm)	4.44" (11.3 cm)	22.63" (57.5 cm)	28.00" (71.1 cm)	31.13" (79.1 cm)	20.00" (50.8 cm)	27.44" (69.7 cm)
S/SV/NGF-250QD	39.88" (101.3 cm)	30.00" (76.2 cm)	9.94" (17.6 cm)	4.44" (11.3 cm)	22.63" (57.5 cm)	28.00" (71.1 cm)	31.13" (79.1 cm)	20.00" (50.8 cm)	27.44" (69.7 cm)

Max Noise dB(A)

Noise emission from all models does not exceed 70 dB(A).

Footprints

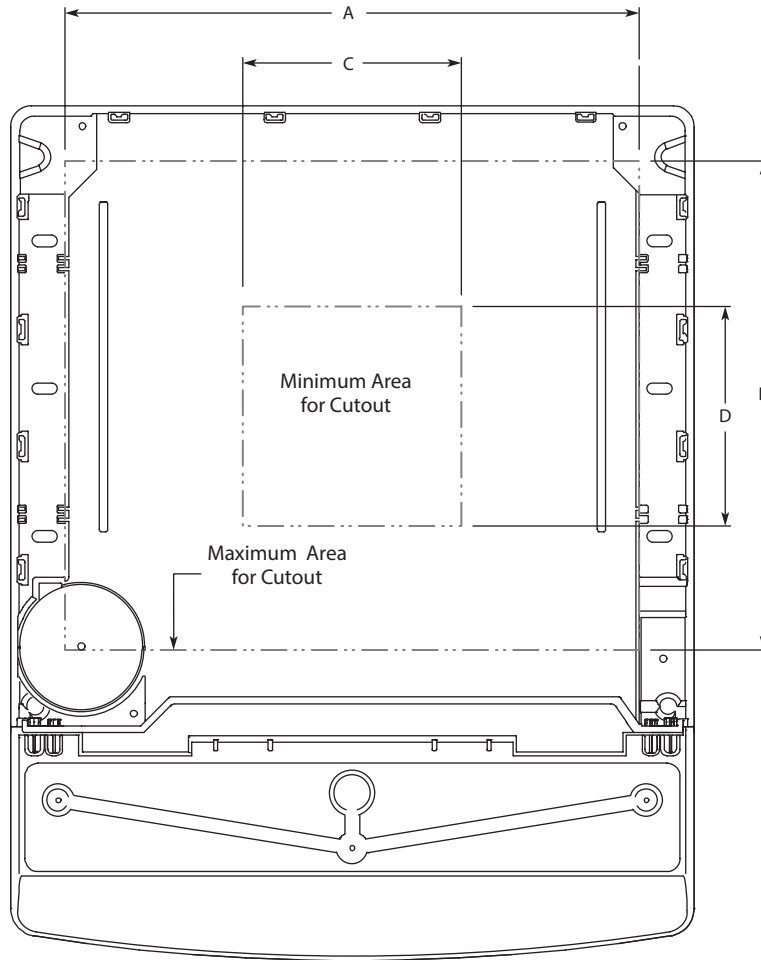

NOTE: Footprint for S/SV-175 shown.

S & SV	Maximum		Minimum	
	A	B	C	D
150	19.00" (48.3 cm)	17.81" (45.2 cm)	8.00" (20.3 cm)	8.00" (20.3 cm)
175	21.00" (53.3 cm)	17.81" (45.2 cm)	8.00" (20.3 cm)	8.00" (20.3 cm)
200	26.00" (66.0 cm)	17.81" (45.2 cm)	8.00" (20.3 cm)	8.00" (20.3 cm)
250*	26.00" (66.0 cm)	17.81" (45.2 cm)	8.00" (20.3 cm)	8.00" (20.3 cm)
250QD*	26.00" (66.0 cm)	17.81" (45.2 cm)	8.00" (20.3 cm)	8.00" (20.3 cm)

*Includes NGF

⚠ Warning

Cutting the countertop may decrease its strength. Counter must be braced to support the dispenser countertop weight plus ice storage capacity and weight of ice machine, if applicable.

Location

The location selected for the beverage dispenser must meet the following criteria. If any of these criteria are not met, select another location.

- Dispenser is only to be installed in locations where it can be overseen by trained personnel.
- The air temperature must be at least 50°F (10°C), but must not exceed 95°F (35°C).
- The location must not be near heat-generating equipment or in direct sunlight and must be protected from weather.
- The countertop must be level. Verify that the countertop can support the weight of the dispenser, or the dispenser/ice machine combination plus the weight of the stored ice.
- Water lines, drains and power outlet must be within 6' (1.8 m) of location.

⚠ Warning

Carbon Dioxide (CO₂) displaces oxygen. Exposure to a high concentration of CO₂ gas causes tremors, which are followed rapidly by loss of consciousness and suffocation. If a CO₂ gas leak is suspected, particularly in a small area, immediately ventilate the area before repairing the leak. CO₂ lines and pumps must not be installed in an enclosed space. An enclosed space can be a cooler or small room or closet. This may include convenience stores with glass door self serve coolers. If you suspect CO₂ may build up in an area, venting of the B-I-B pumps and/or CO₂ monitors must be utilized.

⚠ Warning**Carbon Dioxide (CO₂)****ALWAYS**

- Connect the CO₂ or Gas Cylinder to a reducing valve.
- Secure cylinder upright during use.
- Keep cylinder away from heat.
- Ventilate area after CO₂ leakage.

NEVER

- Try to connect cylinder directly to product container.
- Interconnect soft drinks, CO₂ or gas cylinder equipment with other equipment.
- Drop or throw cylinders.
- Try to unscrew fittings from containers.

This information should be displayed in a position adjacent to the CO₂ supply cylinders at all times.

Ways Equipment Should Not be Used

This equipment should be used only in accordance with the instructions. This equipment is designed to be installed on a counter, dispense ice, and/or carbonate, chill mains potable water, and chill soft drink syrup. It should not be used for any other purpose.

- Do not use the product coils to chill other products than those stated above.
- Do not operate the equipment in a wet environment. Any spillage must be wiped dry immediately.
- The unit should not be installed in small enclosed spaces such as cupboards or pantries, where fresh air flow is restricted and service may not be able to access.
- Keep the unit free from excessive heat and cold.
- Misuse or use of the equipment for any other purpose than those identified above will invalidate any warranty and may constitute a danger to yourself and others.

Location Requirements for Top Mounted Ice Machine Installations

Location — Avoid placing the dispenser and/or ice machine near heat sources such as radiators, ovens, refrigeration equipment and direct sunlight.

Clearances — Refer to the ice machine installation manual for clearances.

Front of ice machine to be flush with front of dispenser — Some ice machines may overhang at the back of the dispenser.

Drains — A separate drain line is required for the ice machine, in addition to a drain line for the ice/beverage dispenser.

Dispensers may require an adapter kit to install some top-mounted ice machines. Contact your local distributor for the correct adapter kit.

For full information about ice machine installation, including clearances, plumbing lines, connections, and electrical requirements, see the ice machine installation manual.

Pre-installation Checklist

When installing any system, first make sure the major components are available. Generally the major components necessary for an installation are:

Pre-mix System:

- CO₂ regulator set
- Product connectors for Figal tank
- Gas connectors for Figal tank
- Beverage dispenser
- Beverage tubing
- CO₂ tank
- Figal beverage tanks
- Stepless (Oetiker) clamps
- Chain for CO₂ tank

B-I-B System also:

- B-I-B connectors
- B-I-B regulator set
- B-I-B rack
- B-I-B syrup boxes

Post Mix System:

- CO₂ regulator set
- Beverage dispenser
- Beverage tubing
- CO₂ tank
- Carbonator
- Stepless (Oetiker) clamps
- Chain for CO₂ tank

Bulk Syrup System also:

- Syrup connectors for Bulk tank
- Gas connectors for Bulk tank
- Bulk syrup tanks

Assembly

INSTALLING BAFFLE FOR ICE MACHINE INSTALLATIONS

S Series Baffle

1. Remove both front panels.
2. Examine the ice machine to see if the machine has four screws on the lower front plastic panels.
3. If there are screws, remove them from the countersunk holes on the front surface of the machine, and save the screws.
4. Install the deflector, using the four screws removed in step three.
5. Four screws and two backing plates are in the kit.
6. If there are no screws on the ice machine (step 2), pierce the thin plastic countersunk holes, install the backing plates and install the deflector using the screws from the kit.
7. Replace the front panels.

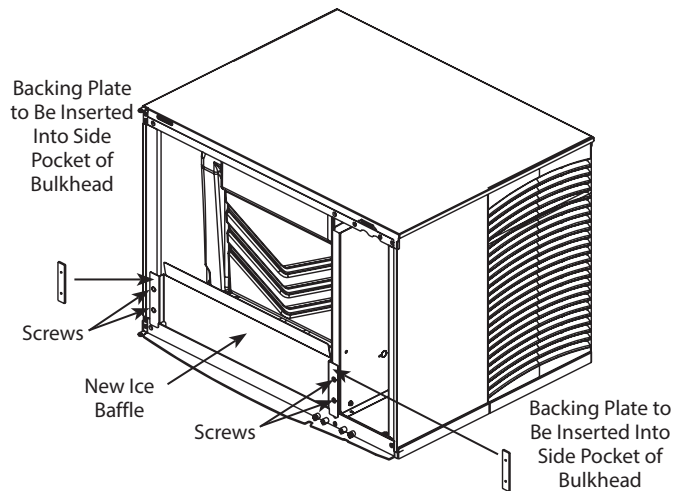

S Series Ice Machine

Q Series Baffle

1. Position baffle on top of water well with tab on the front and the other tab inside the water well.
2. Mount the baffle on the left side of the ice machine using the hole and screw provided.

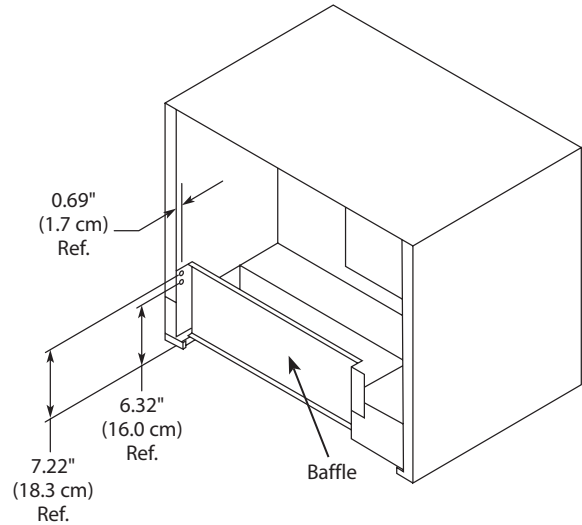

Q Series Ice Machine

Electrical

GENERAL

⚠ Warning

All wiring must conform to local, state and national codes. Changes to the mains cable and plug can only be made by a qualified electrician.

This appliance must be grounded. In the event of malfunction or breakdown, grounding provides a path of least resistance for electric current to reduce the risk of electric shock. This appliance is equipped with a cord having an equipment-grounding conductor and a grounding plug. The plug must be plugged into an appropriate outlet that is properly installed and grounded in accordance with all local codes and ordinances.

MINIMUM CIRCUIT AMPACITY

The minimum circuit ampacity is used to help select the wire size of the electrical supply. (Minimum circuit ampacity is not the beverage/ice machine’s running amp load.) The wire size (or gauge) is also dependent upon location, materials used, length of run, etc., so it must be determined by a qualified electrician.

ELECTRICAL REQUIREMENTS

Refer to Ice Machine Model/Serial Plate for voltage/ amperage specifications.

VOLTAGE

The standard voltage for S/SV/SVI/NGF Series dispensers is 120VAC-60Hz. A power cord is provided with 120VAC-60Hz models only. S/SV/SVI/NGF Series dispensers use a 1/7 hp gearmotor.

⚠ Warning

Improper connection of the equipment-grounding conductor can result in a risk of electric shock. The conductor with insulation having an outer surface that is green with or without yellow stripes is the equipment grounding conductor. If repair or replacement of the cord or plug is necessary, do not connect the equipment-grounding conductor to a live terminal. Check with a qualified electrician or serviceman if the grounding instructions are not completely understood, or if in doubt as to whether the appliance is properly grounded. Do not modify the plug provided with the appliance — if it will not fit the outlet, have a proper outlet installed by a qualified electrician.

MINIMUM CIRCUIT AMPERAGE CHART

Important

Due to continuous improvements, this information is for reference only. Please refer to the dispenser serial number tag to verify electrical data. Serial tag information overrides information listed on this page.

Dispenser	Voltage/Cycle	Minimum Circuit Amps
S-150, S-200, S-250, SV-150, SV-175, SV-200, SV-250, SV-150i, SV-175i, SV-200i, SV-250i, SV-250QD, NGF-250, NGF-250QD	115/60	2.8
	220/50, 220/60, 240/50, 240/60	1.5
	220-240/50	5 (with carb deck)

GROUNDING INSTRUCTIONS

⚠ Warning

The beverage/ice machine must be grounded in accordance with national and local electrical codes.

⚠ Warning

When using electric appliances, basic precautions must always be followed, including the following:

- a. Read all the instructions before using the appliance.
- b. To reduce the risk of injury, close supervision is necessary when an appliance is used near children.
- c. Do not contact moving parts.
- d. Only use attachments recommended or sold by the manufacturer.
- e. Do not use outdoors.
- f. For a cord-connected appliance, the following shall be included:
 - Do not unplug by pulling on cord. To unplug, grasp the plug, not the cord.
 - Unplug from outlet when not in use and before servicing or cleaning.
 - Do not operate any appliance with a damaged cord or plug, or after the appliance malfunctions or is dropped or damaged in any manner. Contact the nearest authorized service facility for examination, repair, or electrical or mechanical adjustment.
- g. For a permanently connected appliance — Turn the power switch to the off position when the appliance is not in use and before servicing or cleaning.
- h. For an appliance with a replaceable lamp — Always unplug before replacing the lamp. Replace the bulb with the same type.
- i. For a grounded appliance — Connect to a properly grounded outlet only. See Grounding Instructions.

PUMP DECK WIRING

The supply cord is equipped with a three-prong 5-15P. When a Ground Fault Circuit Interrupter (GFCI) is required by code, a breaker type protector must be used. We do not recommend GFCI outlets as they are known for more intermittent nuisance trips than panel breakers. To ensure both the safety and proper operation of this equipment, be certain that the electrical receptacle is a proper design so as to accept this plug, ensuring that the carbonator assembly is properly grounded.

If the pump deck is to be installed in an area or community whose local codes require permanent wiring, the following procedure must be followed.

1. The three wires (white, black and green) must be fed through the cable connector and brought into the wiring compartment. The cable must be secured into the connector.
2. The green wire from the cable must be connected to the green screw that attaches to the inside panel of the wiring compartment. Be sure to use a ring torque terminal for connecting the wire to the screw.
3. The white wire from the cable must be joined to the N terminal of the liquid level control board by a suitable U.L. listed insulated cable connector.
4. The black wire from the cable must be joined to the L1 terminal of the liquid level control board by a suitable U.L. listed insulated cable connector.

Water Supply

RECOMMENDED PLUMBING

All plumbing must conform to local, state, and national codes. Manitowoc recommends that a double non-return valve is fitted before the unit on installation. The unit is not connected to the water mains by a factory supplied hose set and it is up to the installer to fit an appropriate food grade hose, rated to a minimum operating pressure of 145 psi (10 bar, 1000000 Pa). All connections should be made using a permanent retaining method e.g. Oetiker clip.

The plumbing diagram is printed on a white vinyl label, located above the inlet tubes for syrup and water. The plumbing diagram label can be accessed by removing the splash panel of the dispenser. The plumbing diagram label explains which inlet coldplate fittings supply which dispenser valves and water manifolds.

The water supply must first be connected to the carbonator pump (not shown) before plumbing to connection "A" shown on plumbing diagram. The carbonator pump deck must be within 6' (1.8 m) of the dispenser for optimum performance. See BIB installation diagram for system pressure settings.

Important

When installing cold carbonated (Intelli carb) equipment, never put a tee for the plain water connection in the line from the pump deck to the cold plate. Putting a tee in the line will create service problems and bad drink quality.

NOTE: Valves are read from right to left.

A check valve must be installed in the water supply line 3' (0.9 m) from the non-carbonated water connection "PW". Contact factory if not installed.

Diagram & Flex Manifold Locations

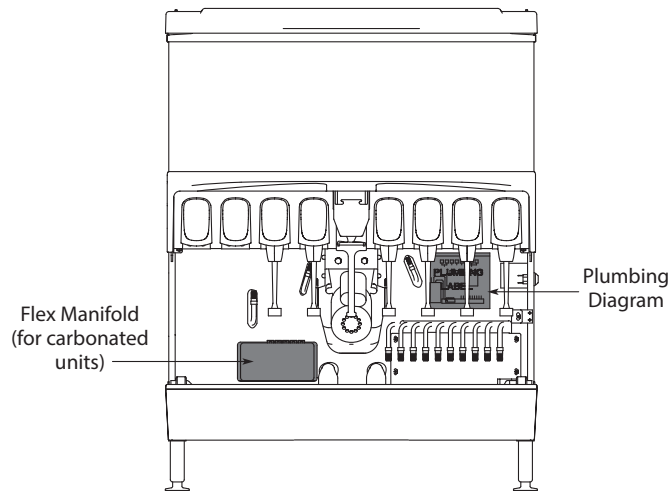

S/SV150 6 Valve Diagram

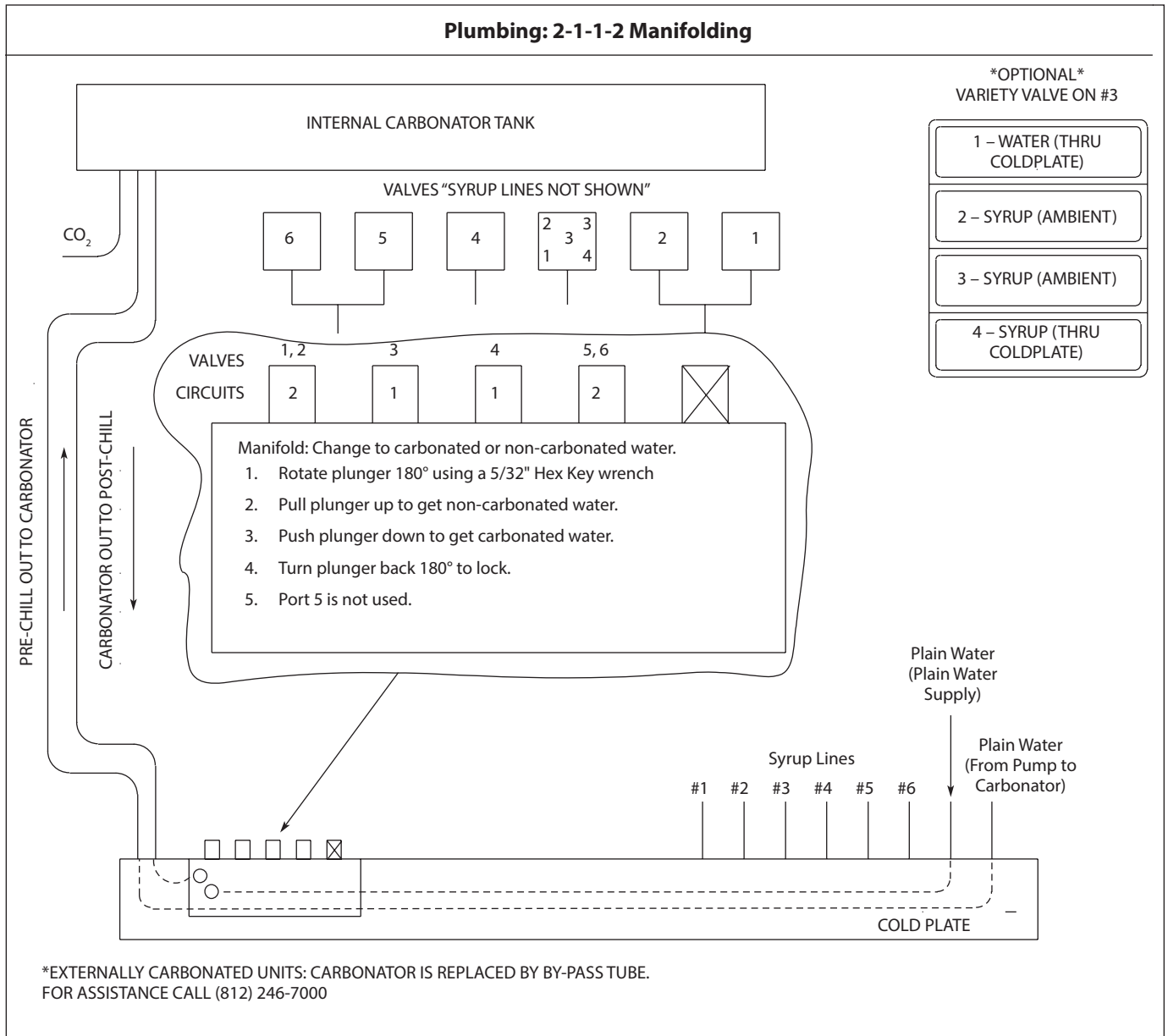

S/SV175 8 Valve Diagram

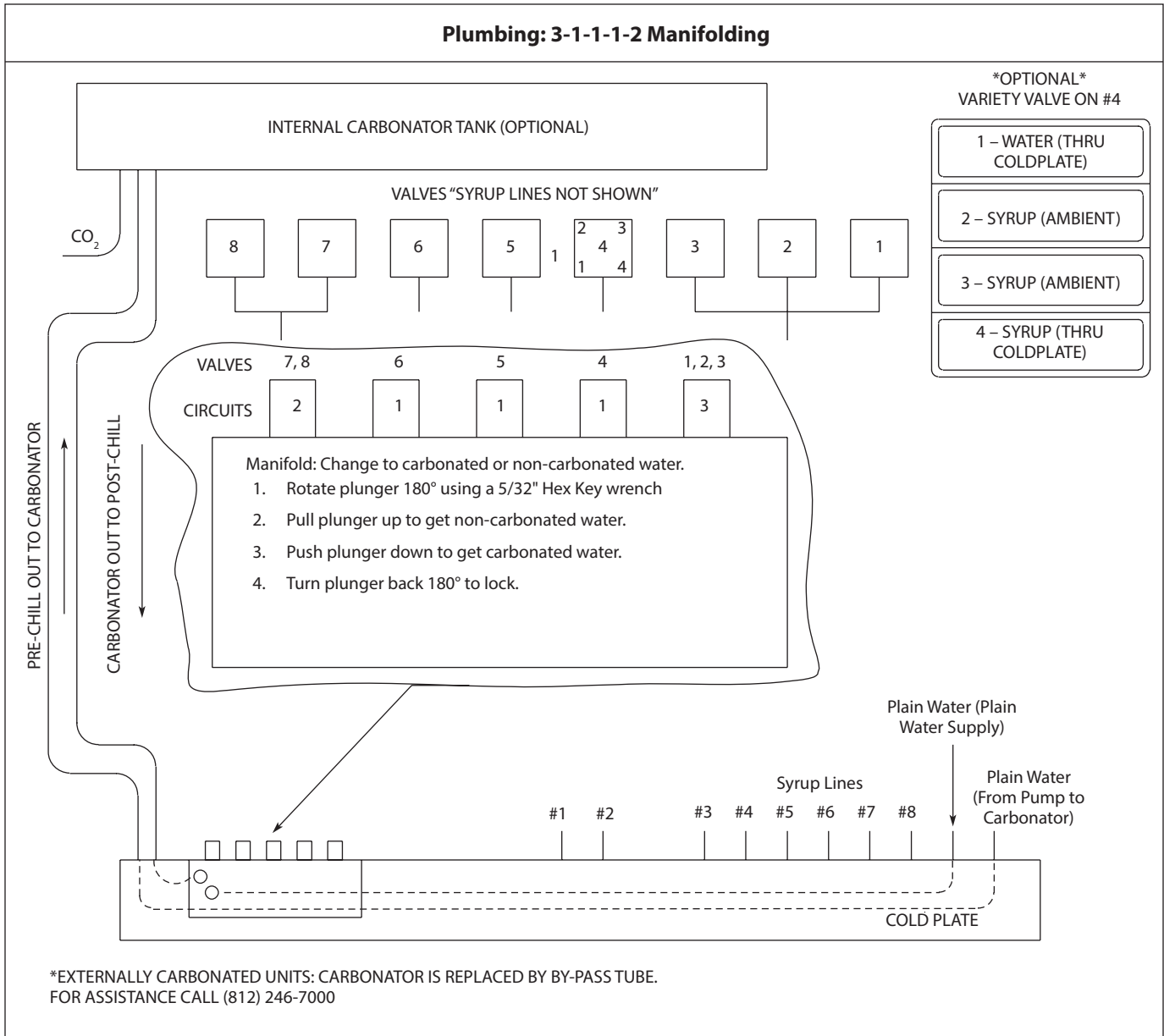

S/SV200/250/SV-250QD 8 Valve Diagram

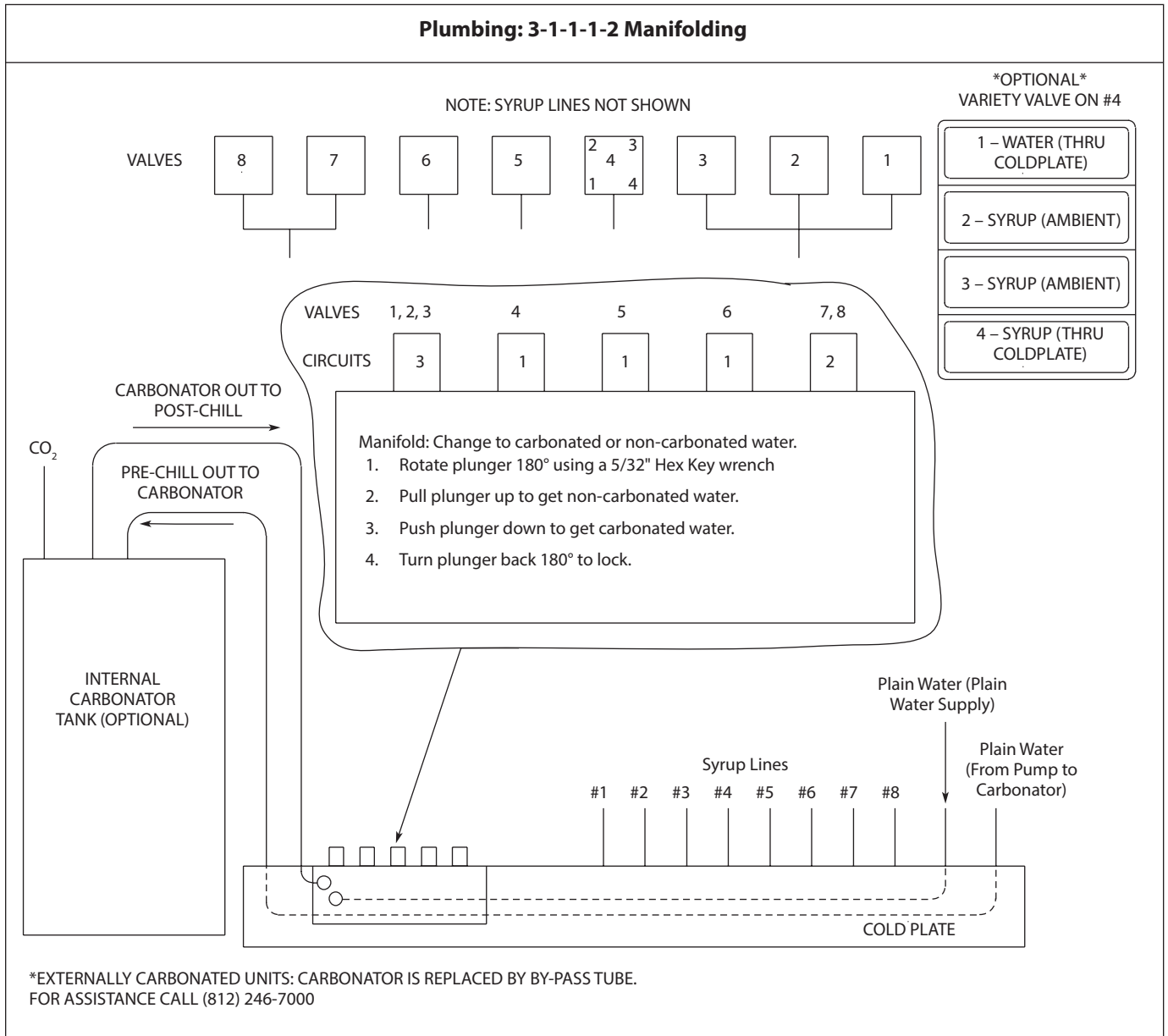

S/SV200/250 10 Valve Diagram

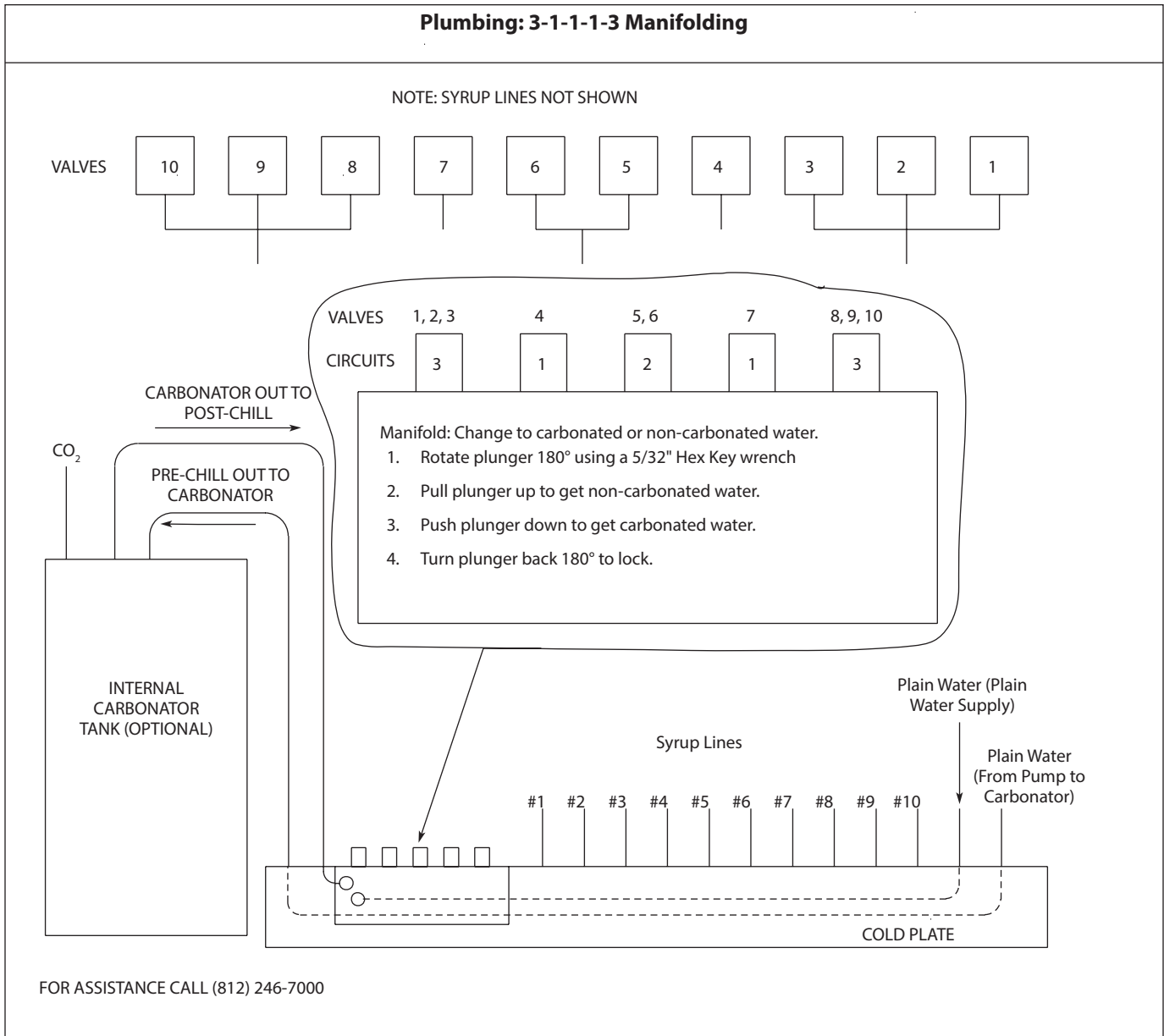

NGF-250 & NGF-250QD 8 Valve Diagram

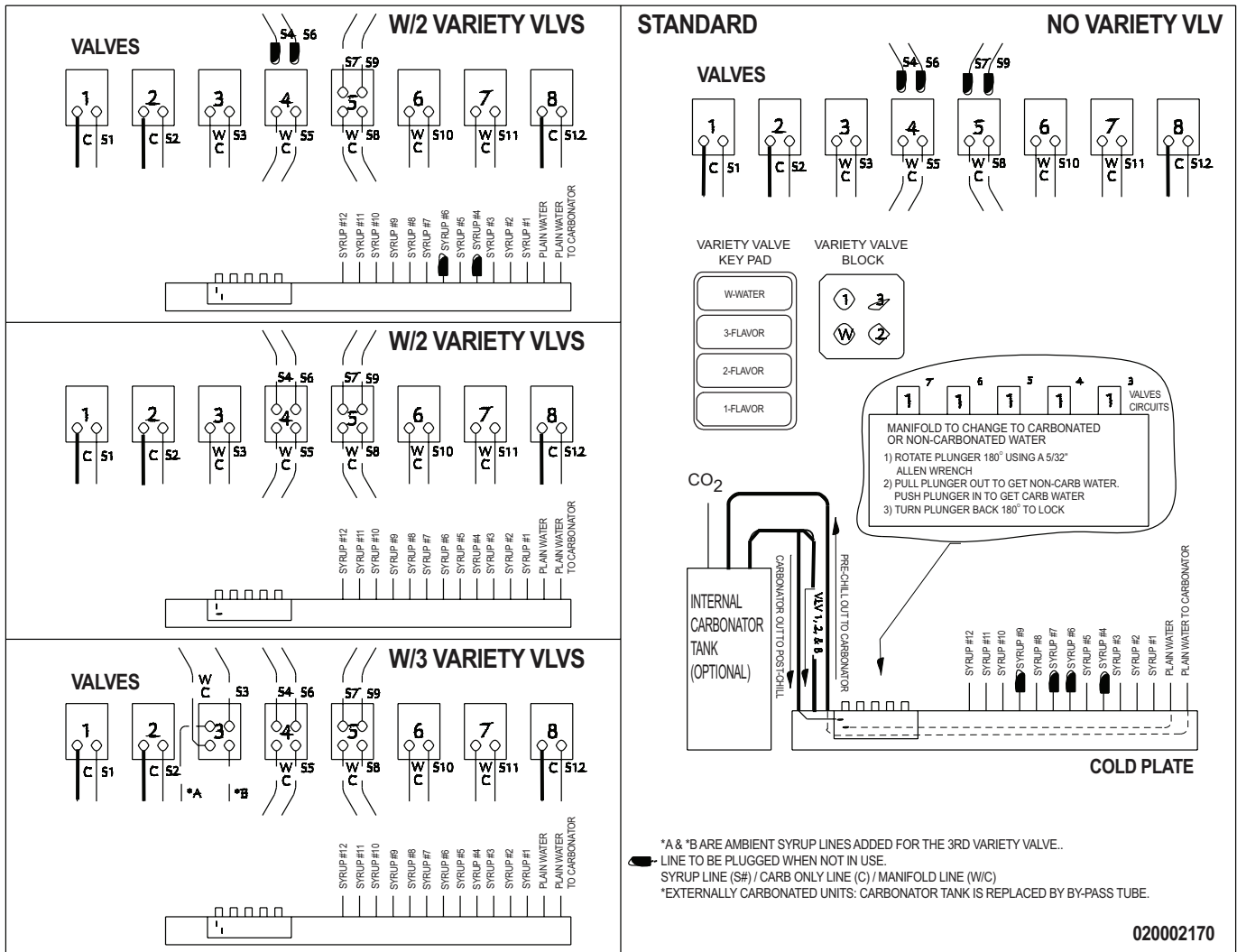

CO₂ Supply

ROUTING INTERNAL CARB TANK PURGE TUBE

Some models are equipped with an internal carbonation tank. These models require that the purge/pressure relief tubing be routed to a drain.

1. Remove the splash panel.
2. Uncoil tubing and route between the front of the dispenser and the drain pan.

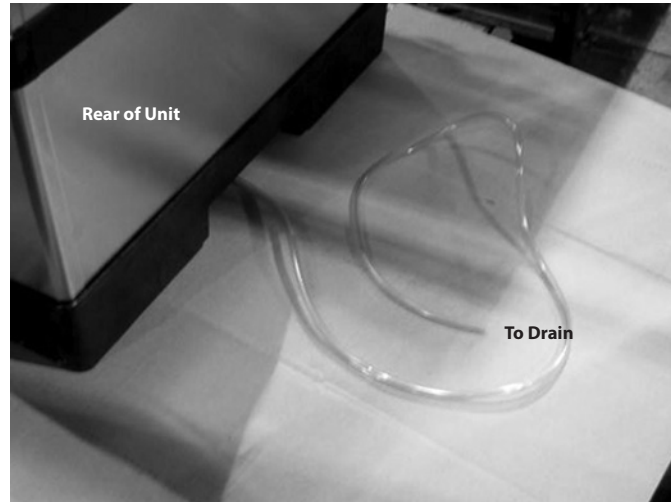
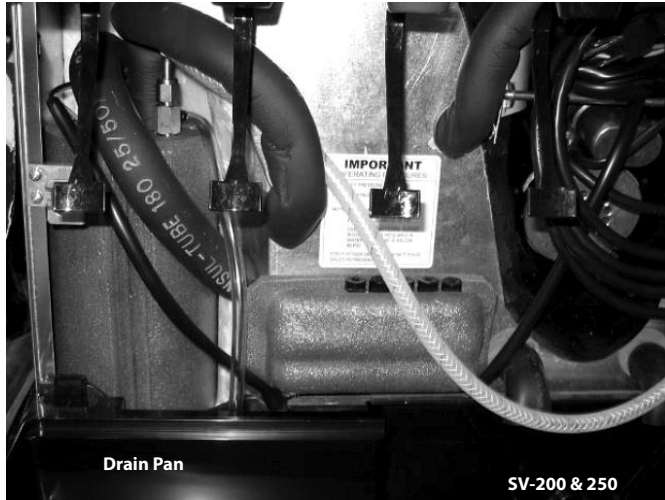

4. Verify the tubing is not kinked and then secure tubing to maintain a minimum 1" (2.5 cm) air gap at the drain. Follow any applicable local or national codes.

3. Depending on drain location, route the tubing through the tubing bundle cutout or out the back of the dispenser.

Drains

S/SV/SVI/NGF Series dispensers drain through a double connection to the drain pan.

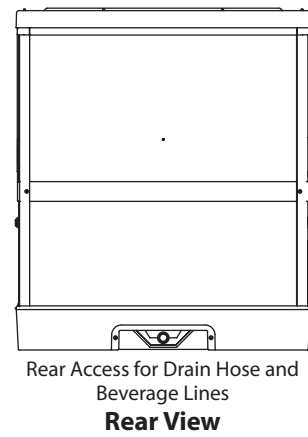
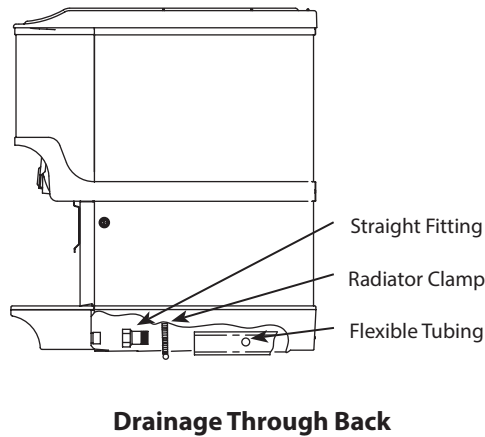
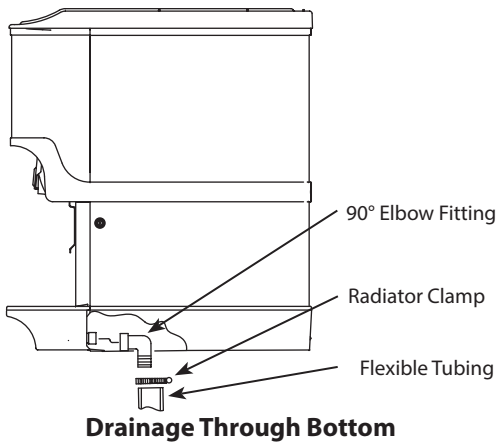

Step by Step Installation

GENERAL

S/SV/SVI/NGF Series dispensers have a stainless steel cabinet and lighted merchandiser standard.

Beverage valves, coldplate connections, drain connections and electrical components are front serviceable.

SPECIFICATIONS CHART

	Min.	Max
Water pressure (Incoming from Water Main)	40 psi (2.76 BAR, 275,790 Pa)	55 psi (3.79 BAR, 379,211 Pa)
Ambient temperature	40°F (4°C)	105°F (41°C)
CO ₂ pressure	40 psi (2.76 BAR, 275,790 Pa)	50 psi (3.44 BAR, 344,738 Pa)
Electrical	115V/60 Hz/1	230V/50-60 Hz/1
Pre-mix pressure		
Normal	60 psi * (4.13 BAR, 413,685 Pa)	
Diet	40 psi * (2.76 BAR, 275,790 Pa)	
B-I-B	60 psi or according to line run (4.13 BAR, 413,685 Pa)	
Carbonation		
Cold	75 psi (5.17 BAR, 517,106 Pa)	
Ambient	90 psi (6.205 BAR, 620,528 Pa)	100 psi (6.89 BAR, 689,475 Pa)
Quickdraw CO ₂ supply	75 psi (5.17 BAR, 517,106 Pa)	
Quickdraw regulator valve	40 psi (2.76 BAR, 275,790 Pa)	50 psi (3.44 BAR, 344,738 Pa)
Quickdraw Carbonation		
Cold	75 psi (5.17 BAR, 517,106 Pa)	
Ambient	90 psi (6.205 BAR, 620,528 Pa)	100 psi (6.89 BAR, 689,475 Pa)

* This is the optimal pressure. When the foam is too high, decrease the pressure; when spitting/popping is an issue, increase the pressure.

UNIT INSTALLATION

- Place the dispenser in the desired location.
- Run the beverage lines and water lines; make sure to install the water connections to the proper inlets. Connection "A" comes from the brass carbonator pump and connection "B" is your plain water supply.

Install Plumbing Drains & Insulate

- Connect Drain Kit to drain pan (see Drains on page 20).
- Extended splash panel units do the following:
 - Remove the extended splash panel from the unit by removing the two (2) Phillips head screws holding it in place.
 - Determine drain setup and screw either the 90° or straight line drain fittings into the collector box included with the drain kit (see Drains on page 20).

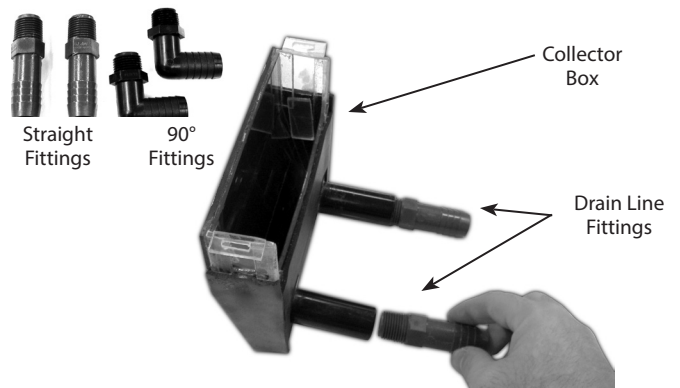

NOTE: Depending on the drain setup, connect the straight fittings to the collector box if the drain lines are to run straight back underneath the unit or the 90° fittings if the drain lines run down through the countertop.

- Using the provided radiator clamps connect and secure the drain lines to the collector box fittings with a standard screwdriver or 5/16 nut driver.

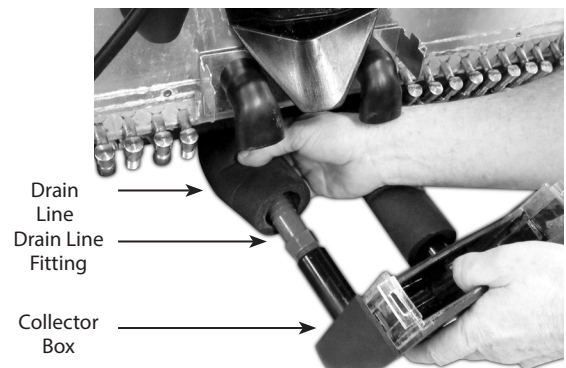

- D. Mount the collector box to the bracket by sliding the right and left bracket tabs into the slots on the collector box.

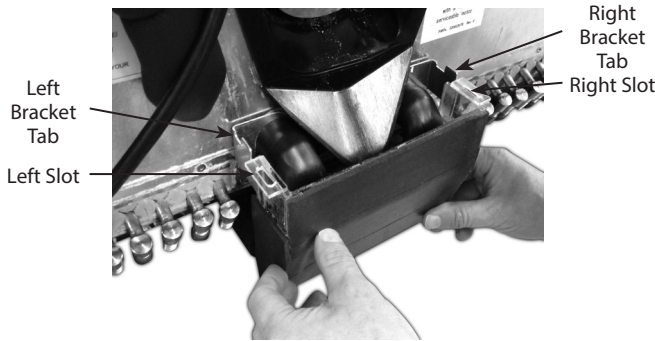

- E. Be sure the 90° rubber ice bin drain elbows are routed into the collector box.

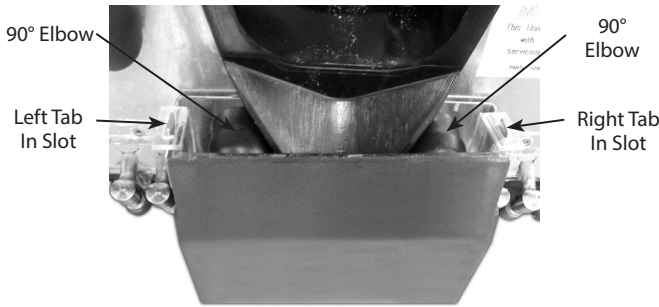

- F. Reinstall the extended splash panel.

5. Fill bin with ice.
6. Set flexible manifold Carb/Non-Carb drinks for correct drink settings (see Recommended Plumbing on page 14).
7. Turn water supply on to the dispenser.
8. Purge air from the carbonator tank. Lift the pressure relief valve tab on the carbonator tank until water comes out of the relief valve.
9. Connect the pump deck control lead to the pump motor.
10. Connect power supply cords. (There are two (2) cords that need to be connected to a 115V power supply.)
11. Brix beverage valves (see Brix Check on page 32) and fill bin with ice.

Important

When installing cold carbonated (Intelli carb) equipment, never put a tee for the plain water connection in the line from the pump deck to the cold plate. Putting a tee in the line will create service problems and bad drink quality.

QUICKDRAW INSTALLATIONS

Warning

Personal Injury - Hazardous Moving Parts

Do not adjust regulator valve above 50 psi (3.44 BAR 344,738 Pa). Recommended operating parameters are 40-50 psig.

The Quickdraw unit requires a supply of CO₂. The pressure requirement for the CO₂ supply is 75 psi (5.17 BAR, 517,106 Pa). The adjustable Ice Dispense CO₂ regulator in the electric box must be set at 40 (2.76 BAR, 275,790 Pa) to 45 psi (3.10 BAR, 310,264 Pa). The Ice Dispense CO₂ Regulator must never be set above 50 psi (3.44 BAR, 344,738 Pa).

Turn CO₂ supply on to the dispenser. Each cold carb pump deck is furnished with a fixed regulator set at 75 psi (5.17 BAR, 517,106 Pa). Ambient units need to be set between 90 psi (6.205 BAR, 620,528 Pa) and 100 psi (6.89 BAR 689,475 Pa).

Important

The ice portion sizes must be adjusted to customer requirements at the time of installation. (See the Quickdraw Ice Portion Adjustments section for more information.)

SETTING PRESSURES

Pre-mix Pressures

Normal pre-mix pressure regulators must be set at 60 psi (4.13 BAR, 413,685 Pa). Diet pre-mix pressure regulators must be set at 40 psi (2.76 BAR, 275,790 Pa). If you are experiencing high foaming, decreasing the pressures may correct the problem. Spitting and popping usually requires slightly increasing the pressures. Pre-mix beverage valve pressures vary by type and manufacturer. Please consult the manufacturer of the valves you are using for specific instructions regarding operation of the valve.

Cold Carb and Ambient System Pressures

1. Incoming tap water - must be at a minimum dynamic pressure of 40 psi (2.76 BAR, 275,790 Pa) and maximum static pressure of 55 psi (3.79 BAR 379, 211 Pa) (measured at inlet to pump).
2. BIB pressure gauge must be set for 60 psi (4.13 BAR, 413,685 Pa) or according to your line run.
3. Carbonator Pressure gauge (Use Preset Regulator):
 - Cold Carbonation set for 75 psi (5.17 BAR, 517,106 Pa).
 - Ambient systems must be set at 90 psi (6.205 BAR, 620,528 Pa) to 105 psi (6.89 BAR, 689,475 Pa).

Important

If incoming water pressure is under 40 psi (2.76 BAR, 275,790 Pa), a water booster is recommended. If incoming water pressure is over 55 psi (3.79 BAR 379, 211 Pa), a water regulating valve is required.

ADA KEY PADS

These instructions are for installations with this option.

1. Remove power from the unit.

Merchandiser Removal

2. Loosen the two knurled fasteners located in the top of the merchandiser that hold the merchandiser in place.
3. Remove the merchandiser by lifting up and tilting forward.

Splash Panel Removal

4. Remove the splash panel from the unit by removing the two (2) phillips head screws holding it in place.

ADA Wiring

5. Route the ADA ribbon cable under the drain pan.



6. Continue routing the ADA cable behind the valve mount cap on the left hand side of the unit.

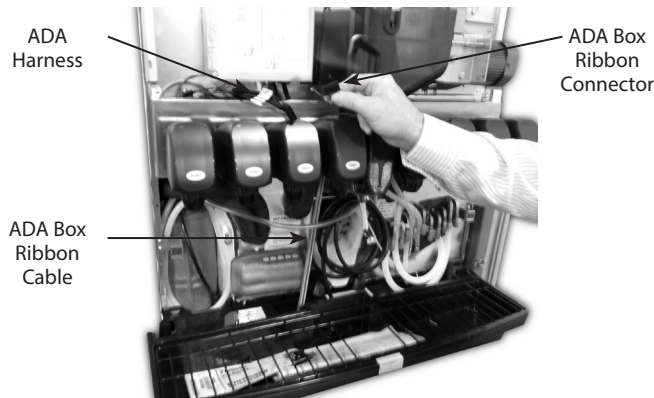

7. Connect the ADA ribbon cable to the ADA wire harness located to the left of the ice chute and held to the foam front by a wire clip.



8. Neatly tuck in and take up any slack remaining in the ADA ribbon cable so it will not be in the way of any moving parts or panels when they are placed back on the unit.

Drain Pan & ADA Touch Pad Box

9. Attach the drain pan to the unit.
10. Center the ADA Key Pad Box with the unit in front of the drain pan and secure into place.

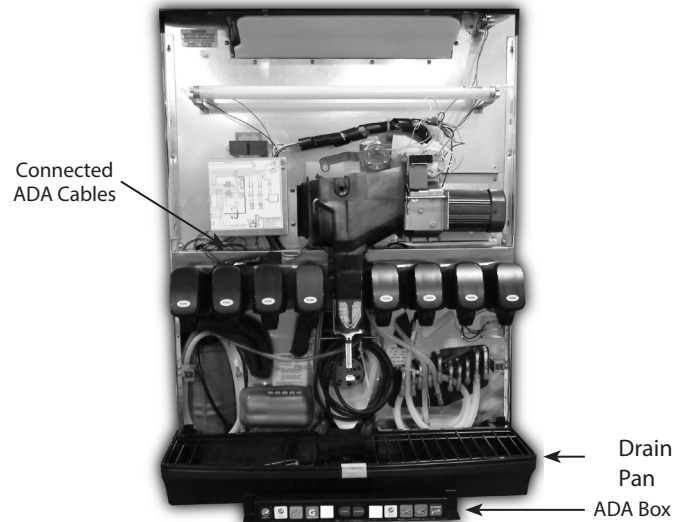

Important

If mounting the ADA Box directly in front of the drain pan on the countertop, leave a minimum of 1" (2.5 cm) space between the bottom edge of the drain pan and the ADA Box to allow space for drain pan removal.

11. Apply corresponding drink labels to the ADA key pads.

NOTE: Drinks correspond from left to right on the left side of the unit, and right to left on the right side of the unit. If buttons are not used they will be blanked out. The Cubed/ Crushed buttons are only utilized on units configured with the Selectable Ice feature. (See ADA Key Pad Matrix.)

ADA Key Pad Matrix

6 Valve Dispensers

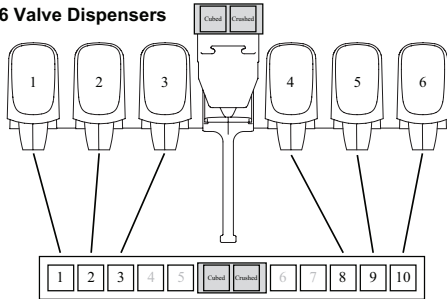

8 Valve Dispensers

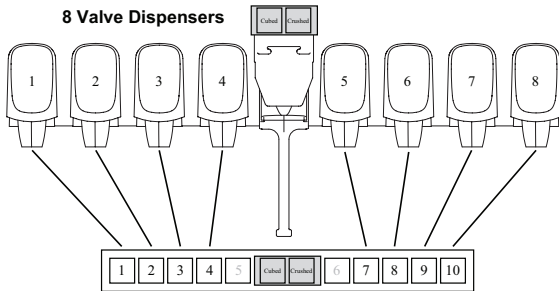

10 Valve Dispensers

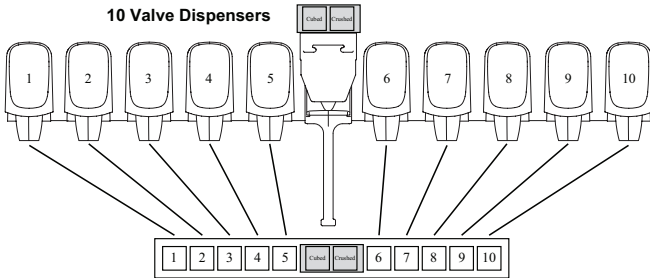

Finish Installation

12. Put the splash panel and merchandiser back onto the unit and reinstall the screws that hold them in place.



13. Restore power to the unit.

STARTING YOUR BEVERAGE SYSTEM & DISPENSER

Upon completion of the beverage dispenser and/or system installation, all tubing, dispenser, and system components must be cleaned and sanitized prior to use.

NOTE: At installation, equipment, dispensers, and tubing get moved through many environments, dirt, dust, chases, insulation, drywall, etc. It is an important procedure and best practice to address cleaning to deliver the best quality drink to your customer.

Important

Clean and sanitize the water and syrup circuits according to instructions provided in this manual. Clean and sanitize the dispenser components according to instructions provided in this manual. Seal to countertop when no legs are used with the unit. Consult and use local health codes if a discrepancy occurs between this manual and your local health codes.

Section 3 Operation

General System Overview

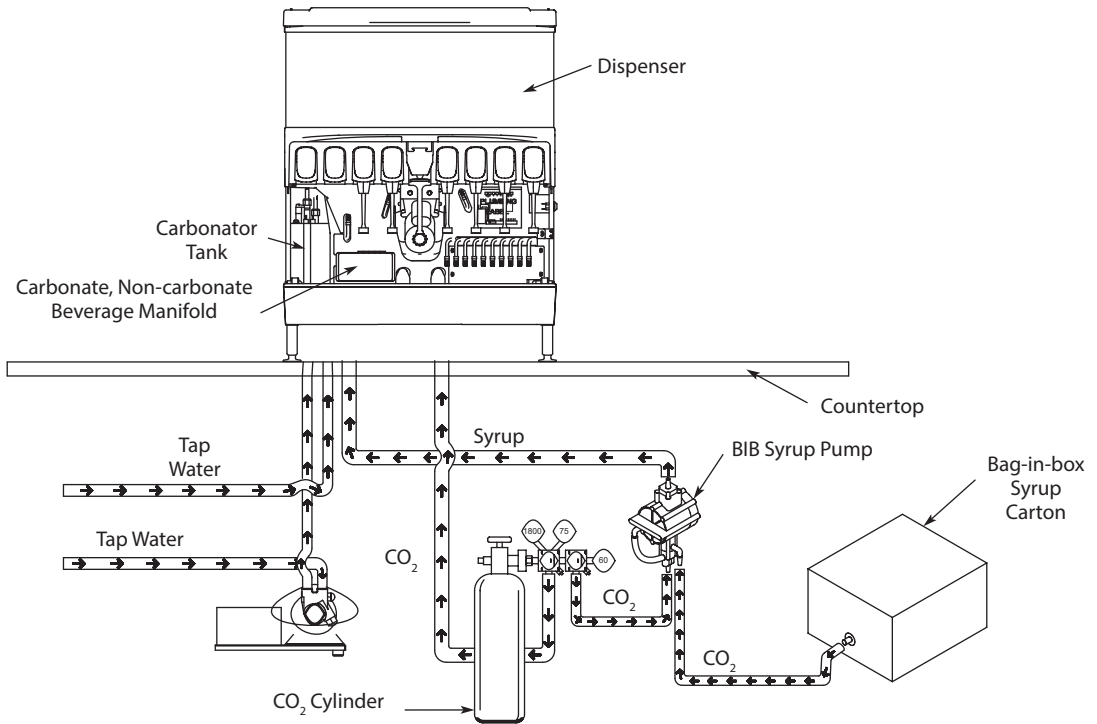

Typical Internal Carbonation Beverage Dispensing System

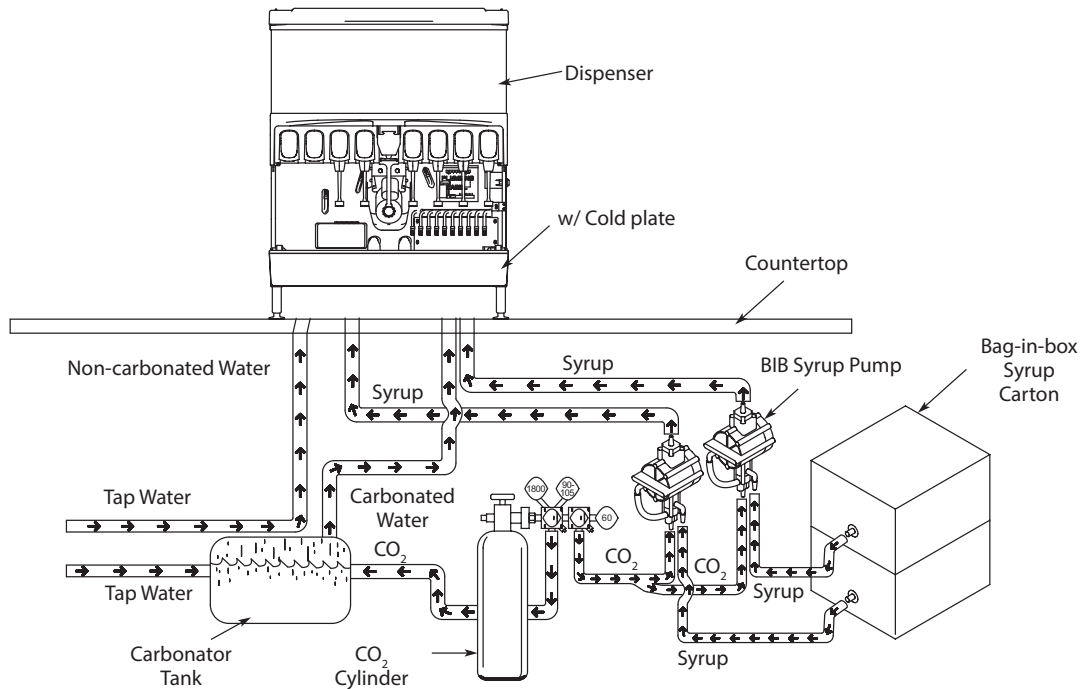

Typical External Carbonation (Ambient) Beverage Dispensing System

Component Identification

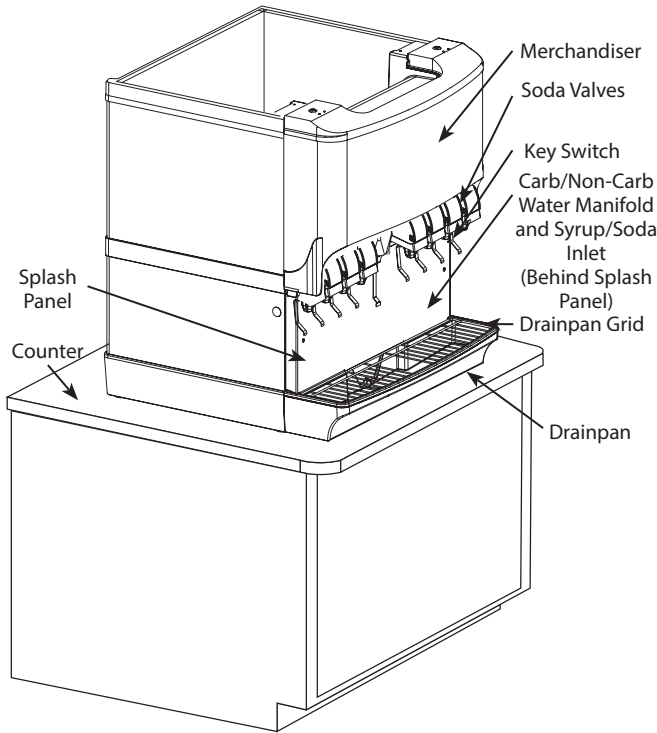

ICE STORAGE AND DISPENSING

As the customer presses the rocking chute, the arm at the top left rear of the chute pushes upward on the door lock. The door opens until it contacts the stops in the mounting brackets. The plastic arm on the ice chute also activates the lever of the ice dispensing switch. When activated, the micro switch starts the gear motor. The gear motor turns the paddle wheel and agitator arm.

The paddlewheel carries ice. Periodic agitation is standard on the 30" and larger dispensers. During periodic agitation, the paddle wheel and agitator turn for approximately three seconds every three and one half-hours. The door lock prevents ice from being dispensed during the agitation cycle.

BEVERAGE VALVES

Post-mix beverage valves are designed to precisely meter the flow of both water and syrup to obtain the proper mixing ratio. The syrup and soda water components of the post-mix beverage are mixed as they leave the beverage valve.

ROCKING CHUTE ICE DISPENSING

As the customer presses the rocking chute, the arm at the top left rear of the chute pushes upward on the door lock. The door opens until it contacts the stops in the mounting brackets. The plastic arm on the ice chute also activates the lever of the ice dispensing switch. When activated, the micro switch starts the gear motor. The gear motor turns the paddle wheel and agitator bar.

Sequence of Operation

ICE RECOMMENDED FOR DISPENSING

Dispensers are designed to dispense hard, cube ice up to one-inch square. The ice shapes and sizes listed below are recommended for dispensing.

Warm "Super Cooled" Ice Before Dispensing: "Super Cooled" ice is not recommended for dispensing. "Super cooled" ice is ice that has been stored in freezers below 32°F. If it is necessary to temporarily use "super cooled" ice, allow the ice to warm at room temperature for 25 to 30 minutes before placing the ice in the dispenser.

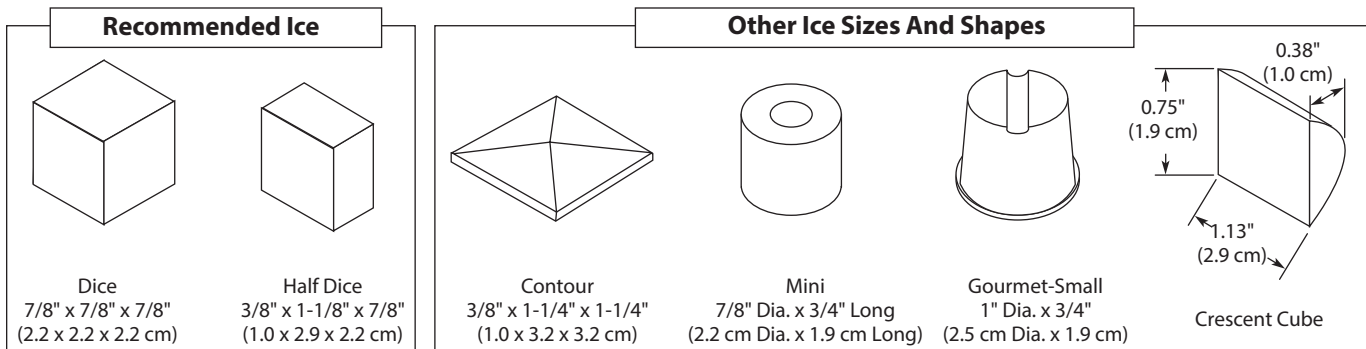

CARBONATION

The purpose of the carbonator is to take regular tap water at street water pressure (minimum 20 psi, maximum 80 psi, dynamic or flowing pressure) 1/2" water line and increase the water to beverage system pressure (usually 100 psi). This water is then combined with the CO₂ gas. Because the water and gas are at the same pressure, the CO₂ will dissolve into the water. Chilling the mixture before dispensing will assist in locking the carbon dioxide into the water. After dispensing, the CO₂ may be unlocked from the liquid. The CO₂ will gradually leave the liquid due to pressure and temperature changes.

Components

The components of the carbonator are: water pump, an electric motor to operate the pump, carbonator tank where the water and CO₂ mix, and a water level control.

Operation

Carbon Dioxide (CO₂) leaves the storage tank and arrives at the carbonator tank through the gas inlet. Water supply enters the carbonator pump inlet at regular street water line pressure (minimum 20 psi, maximum 80 psi, dynamic or flowing pressure). The water pump increases the pressure of the water, which allows the water to flow into the carbonator tank. The CO₂ and the water mix together in the carbonator to produce the carbonated water that is then sent to the soda dispenser.

The agitation of the water and CO₂ together in the tank under high pressure creates the soda water. The quality of carbonation (percent of CO₂ mixed in the water) increases as the water temperature decreases and exposure time increases.

The water level in the carbonator tank is controlled by a water level control in the tank. This control turns the pump motor off and on to maintain a preset level of liquid in the tank. The water level control may be electronic probes or a mechanical float.

SYRUP DELIVERY SYSTEM

Your syrup location can vary depending on the volume of beverages served and ease of accessibility. Your beverage system may sit in a back storage room or under the counter of the dispenser. Configurations are almost limitless. Check the temperatures expected for the storage location. Adverse temperatures can affect the storage and quality of beverage products. It is recommended the temperature of storage location must not fall below 40°F (4°C) or rise above 90°F (32°C).

BACK ROOM PACKAGE

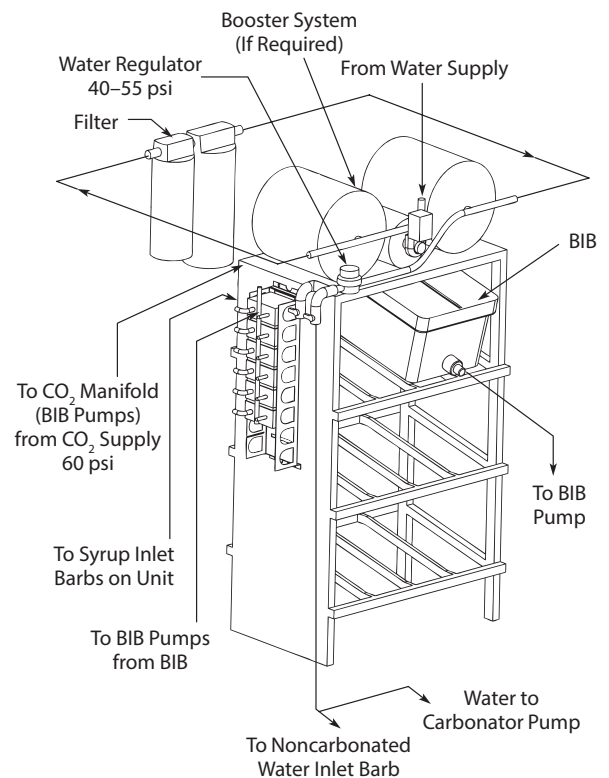

1. Incoming tap water – must be at a minimum dynamic pressure of 40 psi and maximum static pressure of 55 psi.
2. Carbonator Water pump motor – Powers the water pump. The water pump motor is part of the carbonator pump deck.
3. Carbonator Water pump – Pumps tap water into the carbonator tank. The water pump is part of the carbonator. The incoming water for the carbonator must be first run through the pump before connecting to the proper cold plate inlet.
4. Internal/External Carbonator tank – Combines CO₂ gas and tap water to form carbonated water. The “carbonator” is the carbonator tank, water pump and water pump motor.
5. CO₂ cylinder – Holds highly pressurized carbon dioxide (CO₂). The CO₂ cylinder is a steel or aluminum cylinder tank. CO₂ gas flows through the primary pressure regulator.
6. BIB pressure gauge – Set for a minimum of 60 psi. Indicates CO₂ pressure going to B-I-B pumps.
7. Primary pressure regulator – Lowers the CO₂ gas pressure to 100 psi, so the CO₂ gas will be at the proper pressure to enter the carbonator regulator.

8. Lowered outgoing pressure – Set for 75 psi. Gauge indicates lowered outgoing pressure from the CO₂ cylinder after being routed through the primary pressure regulator at 100 psi.
9. Secondary pressure regulator – Lowers the CO₂ gas pressure before the CO₂ gas flows to the syrup pump. CO₂ pressure activates the syrup pump.
10. Syrup pump – Draws syrup out of the bag-in-box syrup package. Syrup flows through the syrup lines to the dispenser for chilling, then dispensing. There is a syrup pump for each bag-in-box syrup system.
11. Bag-In-Box syrup cartons – Box which contains a plastic bag, filled with syrup.

RACKING

Regardless if you are working on a B-I-B or Figal system, a rack will be designated for placement of the product. A rack (or shelf) system affords systematic placement and complete usage of the beverage paid for. The B-I-B rack allows the boxes to lay properly for syrup dispersal. Please check with your B-I-B syrup supplier. Some boxes must be slightly tilted down, while others may be in virtually any position. The Figal tank rack keeps the newer and full tanks organized at one end of the beverage line with the partial tanks at the other.

B-I-B

The Bag-In-Box system refers to a plastic disposable bag. The B-I-B normally contains 5 gallons of syrup, however some locations offer 2-1/2 gallon B-I-B units. This plastic bag is then held inside a cardboard or other container. B-I-B systems are for post-mix applications only.

PUMPS

The syrup in a B-I-B system is delivered to the beverage system through gas operated pumps. These pumps extract the syrup out of the bags, forcing the syrup throughout the system.

AUTO BAG SELECTORS

These are used on higher volume B-I-B systems where two or more bags of the same product are connected to one pump and one system. An auto bag selector is essentially a valve that automatically changes from one bag (or series of bags) to another bag (or series of bags) of syrup as the bags empty, allowing a constant flow of product.

FIGAL SYSTEM

Figal refers to the stainless steel tanks of pre-mix beverage or post-mix syrup. A small CO₂ tank pushes the beverage out of the Figal tank.

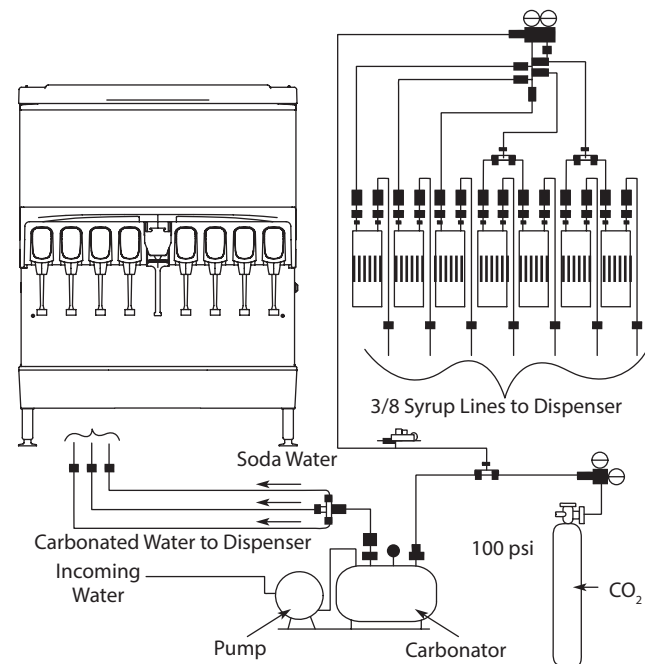

FIGAL TANKS

The stainless steel Figal beverage tanks are easy to store and connect. When using the Figal tanks:

- Use a gas connector for the inlet fitting of the tank.
- Use a syrup connector for the outlet fitting of the tank.
- If more than one Figal tank is connected in series, when changing tanks, remove the tank closest to the original gas inlet while adding the new tank to the connector closest to the syrup outlet.

Most Figal tanks have a self-closing valve on the tank as well as the gas and syrup connectors. This allows the operator of the system to change tanks without having to shut down the entire system. With this type of connector, push down on the connector while pulling up on the snap ring around the opening of the connector. Then simply pull the connector off the tank.

AGITATION TIMER

The timer is non-adjustable and is set to agitate the ice for 3 seconds every 3.5 hours. Activating the dispenser will reset the timer. After 3.5 hours of non-use, the timer will energize the dispenser motor.

The LED tells the technician in which mode the timer is operating. Rather than a jumper pin, this timer has a female spade connector that must be connected to terminal number 6.

When this jumper is in place, the LED will blink at one-second intervals. This is the run mode.

When the jumper is open, the LED will flash every 0.4 second. This is the test mode and the timer will cycle every 55 seconds in test mode. If the timer is left in test mode, it will automatically reset to run mode.

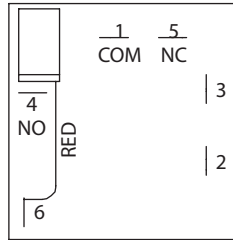

Agitation Timer

Important

Quickdraw ice & beverage dispensers do not have an agitation timer and need to be left in Auto Mode at night so periodic ice agitation takes place.

Operation Checks and Adjustments

ROCKING CHUTE ICE DELIVERY SWITCH ADJUSTMENT

To properly adjust the switch, first unplug the power cord to the unit, then remove the merchandiser. This will give you access to the ice delivery switch located on the left side of the rocking chute.



Begin by observing the chute by slowly pushing against the rocking chute. When the ice delivery switch clicks, measure the distance from the door stops on the rocking chute bracket to the door. The distance between the two must be no more than 1/4" (0.64 cm), but no less than 1/16" (0.16 cm).

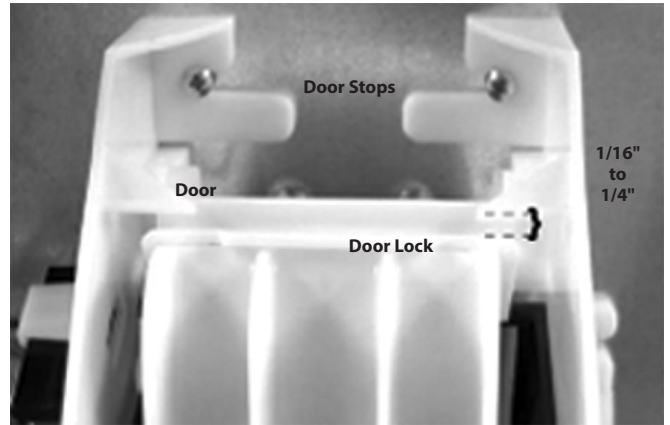

The left side of the rocking chute has a tab that pushes up on the ice delivery switch. To adjust it, use needle nose pliers and bend the arm of the switch up or down in order to change the point where the tab makes contact with the switch arm.

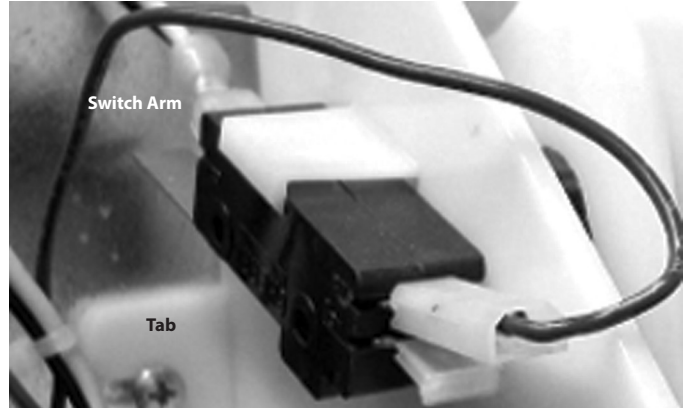

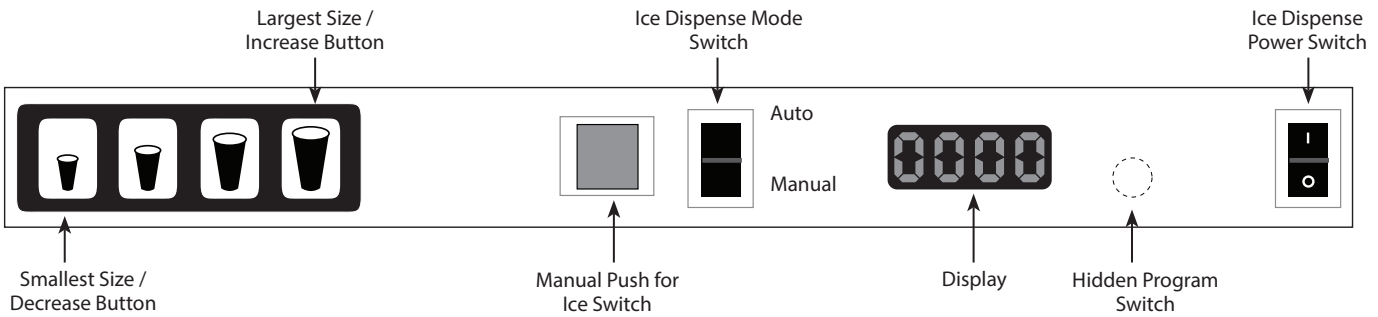

QUICKDRAW ICE PORTION ADJUSTMENTS

The Quickdraw ice dispensing system has adjustable ice portion sizes. Follow the directions below to set the ice portion size. Each portion size must be checked according to customer specification at the time of installation.

1. To set the ice portion sizes, press the program switch 1 time in 3 seconds. The display will read "0001".
2. Press the ice portion size that is to be adjusted. Once the portion size that is to be adjusted is pressed, the display will show the present pulse setting for that size.
3. To increase the portion size, press the largest size button. To decrease the portion size, press the smallest size button.

NOTE: The pulse count will increase, or decrease, by 1 with each press of the smallest or largest size buttons.

4. Press the program button 1 time to exit program mode and save settings.
5. Repeat steps 1 through 4 for each cup size as necessary.

NOTE: For Data Display Mode and Test Mode instructions, please refer to the Quickdraw Ice Portion Control Program flow chart in this manual.

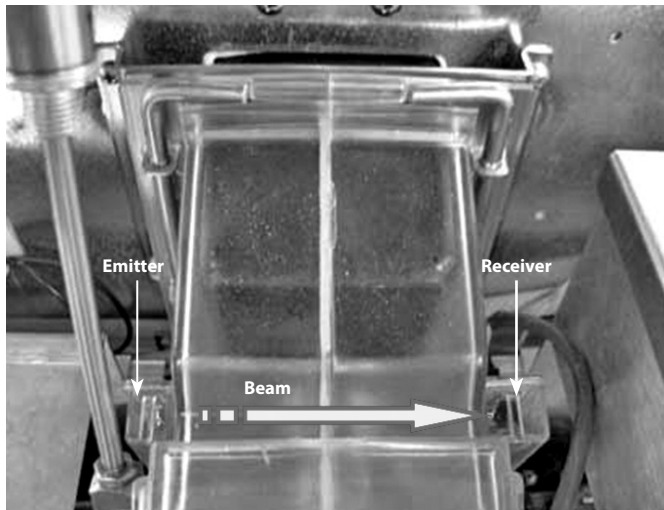
SENSOR BEAM**Sensor Beam Sequence of Operation**

1. Ice fills the ice chute until it interrupts the beam.
2. Paddlewheel stops.
3. Ready for the next portioned dispense.

Adjustment

1. Loosen screws on left & right side of assembly.

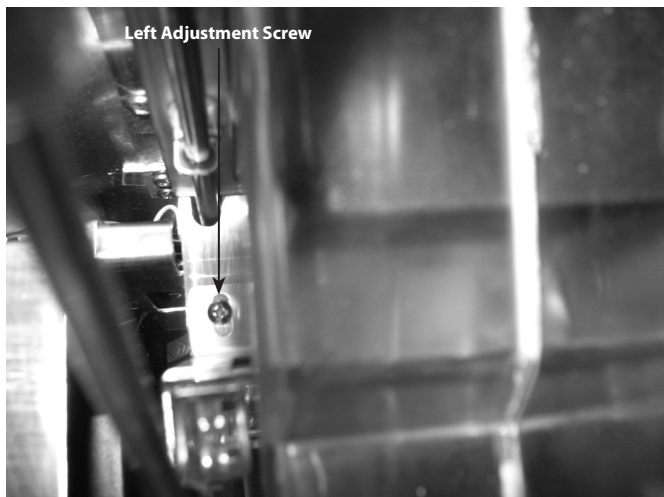

2. Adjust sensor board sensor eyes to the center of the rectangular window on ice chamber.



3. Tighten screws on left and right side of assembly.
4. Test the Quickdraw.

BRIX CHECK

Step 1 - Gather Tools

Tools you will need; brix cup and S tube.

NOTE: Follow instructions on 2a or 2b depending on Valve Type that is being checked.

Step 2a - Attaching S Tube To Multi-flavor Valve



- Remove nozzle and syrup diffuser from valve.
- Slide white end of S Tube over tip of diffuser snugly.
- Re-attach nozzle and diffuser with S Tube in place.
- Select flavor to brix.

Step 2b - Attaching S Tube To Single Flavor Valve



- Remove nozzle and syrup diffuser from valve.
- Slide white end of S Tube over tip of diffuser snugly.
- Re-attach nozzle and diffuser with S Tube in place.

Step 3 - Prime S Tube



After nozzle has been re-attached, dispense a small amount of product to fill up the S Tube.

- This is necessary to ensure an accurate reading.

Step 4 - Fill Brix Cup

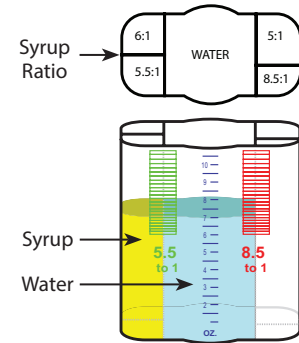

High-Yield Brix Cup

- Position the large end of the brix cup under the valve. At the same time, insert the free end of the S tube into the proper syrup chamber. See diagram above for reference.
- Dispense product until product reaches the grid on the Brix cup.

NOTE: The water should be clear. If the water is not clear, the S-tube has not been attached correctly to the syrup diffuser. Repeat step 2.

Step 5 - Read The Brix

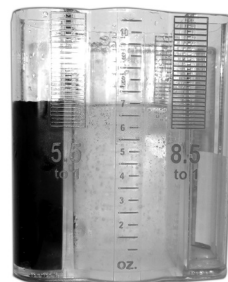

Pepsi-Cola Company	
Syrups and Ratios	
6:1	Pepsi and Sierra Mist (High Yield)
5.5:1	Mountain Dew (High Yield)
8.5:1	Diet Pepsi (High Yield)
5:1	All Other Products

Beverage ratio is in spec. if water and syrup levels are ± 2 bandwidths.

Target	Acceptable

- Remove filled brix cup from dispenser and tap on counter 3 times. Place on flat surface.
- Look at the grid lines. The water and syrup levels should be +/- 2 bars of each other.
- Repeat steps 1-5 for each different product that will be brixed.

NOTE: If Brix ratio is not correct, contact service company.

Section 4 Maintenance

Cleaning & Sanitizing

GENERAL

You are responsible for maintaining the dispenser in accordance with the instructions in this manual. Maintenance procedures are not covered by the warranty.

Clean and sanitize the dispenser every six months for efficient operation. An extremely dirty dispenser may require more frequent cleaning and sanitizing due to operating environment and/or water quality. If the dispenser requires more frequent cleaning and sanitizing, consult a qualified service company to test the water quality and recommend appropriate water treatment.

⚠ Warning

Never use a high-pressure water jet for cleaning or hose down or flood interior or exterior of units with water. Do not use power cleaning equipment, steel wool, scrapers or wire brushes on stainless steel or painted surfaces.

DAILY CLEANING

All cleaning must meet your local health department regulations. The following cleaning instructions are provided as a guide.

⚠ Caution

Use only warm soapy water to clean the exterior of the tower. Do not use solvents or other cleaning agents. Do not pour hot coffee into the drain pan. Pouring hot coffee down the drain pan can eventually crack the drain pan, especially if the drain pan is cold or still contains ice.

⚠ Warning

This Electric Shock Hazard

Unplug unit before servicing or cleaning.

⚠ Warning

When using cleaning fluids or chemicals, rubber gloves and eye protection must be worn.

Clean the exterior and drain pan:

1. Turn off the key switch located on either right or left side of the unit.
2. Lift the grid and remove it from the drain pan.
3. Using mild soap, warm water and a clean cloth, wipe the drain pan and splash panel. Then, rinse with clean, warm water. Allow plenty of warm (not hot) water to run down the drain of the drain pan, to remove syrup residue that can clog the drain opening.
4. Wash the grid, then rinse with clean water. Place the grid back in the drain pan.
5. Wash all exterior surfaces of the unit with warm water and a clean cloth. Wipe again with a clean, dry cloth.
6. Clean the dispensing valves:
 - Remove nozzles and diffusers from beverage valves.

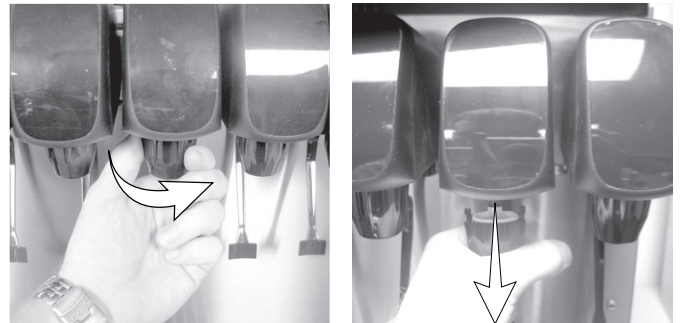

Nozzle Removal

- Rinse nozzle and diffuser with warm, clean water.
 - Clean nozzles and diffusers with soapy water and a soft bristle brush.
7. Clean the underside of the beverage valves with warm, soapy water. Rinse with clean damp towel.
 8. Replace nozzles and diffusers on valves.
 9. Turn on the key switch.

Cleaning/Sanitizing Procedure

This procedure must be performed a minimum of once every six months.

- The dispenser and bin must be disassembled, cleaned and sanitized (See Disassembly in this section).
- All ice produced during the cleaning and sanitizing procedures must be discarded.
- Removes mineral deposits from areas or surfaces that are in direct contact with water.

⚠ Warning

Unplug unit before servicing or cleaning ice bin.

Ice bin contains parts that can move at any time and will cause injury if hands are in the way.

⚠ Warning

When using cleaning fluids or chemicals, rubber gloves and eye protection must be worn.

Clean and sanitize the ice bin:

1. Unplug unit and remove all ice from the ice bin.
2. Mix a solution of mild detergent to clean the dispenser bin and components.
3. Wash the ice bin using a sponge and the mild detergent solution.
4. Using the mild detergent solution and a soft bristle brush or clean cloth, clean the following dispenser parts:
 - Entire bin
 - Paddle wheel
 - Paddle wheel area
 - Agitator
 - Paddle wheel pin
 - Ice chute
 - Rear bushing
 - Motor shaft
 - Strip lids (where applicable)
5. Rinse all the parts in clean, running water.

6. Prepare approximately 2 gallons (7.6 liters) of sanitizing solution by mixing 1/2 ounce (15 ml) of household bleach (that contains 5.25% sodium hypochlorite) with 2 gallons (7.6 liters) of 120°F water. The mixture must not exceed 100 PPM of chlorine. Or mix a solution of any approved sanitizer, following the directions for mixing and applying the sanitizer.
7. Sanitize the ice bin and cold plate with the sanitizing solution for at least 10 seconds.
8. Allow to air dry. Do not rinse.

Re-assembling the dispenser parts:

9. Re-assemble parts in the following order:
 - Bin liner
 - Paddle wheel
 - Agitator
 - Paddle wheel pin
 - Ice chute
 - Merchandiser
10. Hand tighten all knurled fasteners.
11. Pour in fresh, sanitary ice and replace the plastic lid on the top of the dispenser.
12. Plug in the unit's electrical cord.
13. Check for proper ice dispensing.

CLEANING CHECKLIST

- Check CO₂ supply. If CO₂ supply is low, an arrow on the primary regulator gauge will point to a shaded area that reads "Low CO₂" or "Change CO₂ Cylinder."
- Check syrup supply.
- Clean drain pan, grid, and splash panel.
- Clean the valve nozzles and diffusers.

Preventative Maintenance

Preventative maintenance is a vital part of keeping your dispenser in top condition. Following the guidelines below will assist you in continued trouble-free operation of your unit.

1. Conduct daily maintenance of the machine.
2. Perform monthly maintenance of the machine.
3. Perform periodic maintenance and sanitizing of beverage system.
4. Do not overfill the dispenser bin with ice.
5. Do not allow the dispenser to sit for prolonged periods of non-use with ice in the bin.
6. Most ice dispenser service problems are caused by low usage of the ice dispenser.
7. Do not allow ice to remain in the bin more than a day in order to prevent ice from freezing together and/or stagnant ice.

Possible excess ice storage reasons:

- Storage capacity exceeds daily requirements.
- Low demand during the off-season.
- Dispenser oversized with future growth in mind.

Lower ice storage to meet one day's needs. If you manually fill ice, fill only with the appropriate amount of ice. Fill the dispenser with fresh ice each morning. Do not fill the dispenser at night just before shut down. Ice cubes can freeze together if not dispensed.

Disassembly

DISASSEMBLY FOR CLEANING & MAINTENANCE

NOTE: Sanitize the ice dispenser at Initial Start-up in addition to monthly sanitizing. You will need a slotted screwdriver in order to disassemble.

Disassemble parts in the following order:

- A. Merchandiser
- B. Ice chute
- C. Paddle wheel or agitator pins
- D. Agitator
- E. Paddle wheel
- F. Bin liner
- G. Paddle wheel area

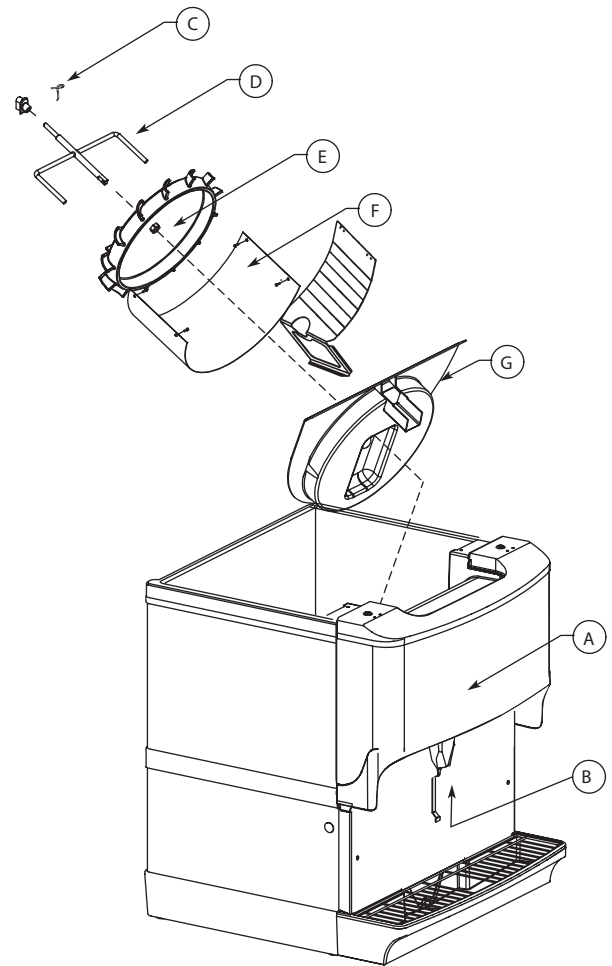

Beverage/Ice Dispenser

Accessing a Dispenser Bin Top Mounted with a Manitowoc Ice Machine:

1. Remove the front panel of the ice machine.
2. Remove the ice deflection baffle. This will give you access to the dispenser bin.
3. If the Manitowoc ice machine is operating, wait for the sheet of ice to fall into the dispenser bin, then place toggle switch of the ice machine to the OFF position. If the Manitowoc ice machine is NOT operating, place the toggle switch of the ice machine to the OFF position right away.
4. On models without a top mounted ice machine, remove the plastic lid from the top of the dispenser.
5. Remove all ice from the dispenser.
6. Disconnect electrical power to the dispenser.

7. Remove agitator arm and paddlewheel pin.

Non-front Serviceable Motor

- a. Rotate the agitator arm so the paddle wheel pin handle is pointing up, toward the ceiling.
- b. Prepare agitator pin for removal by removing the stainless steel split ring.
- c. Then remove the paddle wheel pin from the hole in the agitator.
- d. Push the agitator bar toward the back of the unit until the agitator is free of the paddle wheel hub.

Front Serviceable Motor

- a. With agitator arm in any position remove hitch clip pin from the mushroom bushing on the rear of the ice bin.
- b. Push the agitator bar toward the bushing to remove it from the paddle wheel hub.

NOTE: If a top mount ice machine is installed, sliding the ice machine to one side will make bin component removal easier. If the ice machine is hard plumbed it will need to be disconnected.

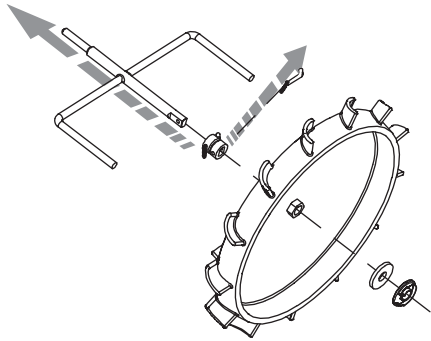

Non-front Serviceable

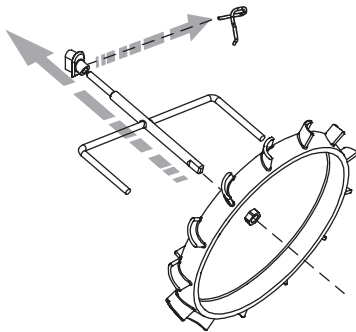

Front Serviceable

8. Remove paddle wheel, bin liner and paddle wheel area.
9. Move the front of the agitator to one side and slide the agitator forward until the rear of the agitator shaft is clear of the bushing.
10. Remove the agitator from the bin area.
11. Slide the paddle wheel from its shaft.
12. Loosen the four knurled fasteners that hold the bin liner in place.
13. Remove the bin liner.
14. Remove the paddle wheel area from the bin.
15. Discard the remaining ice in the bin.

DISASSEMBLE THE ROCKING CHUTE

NOTE: For all Quickdraw units, refer to Quickdraw Components in this section for ice chute information.

1. Loosen the two knurled fasteners that hold the merchandiser in place.
2. Remove the merchandiser.
3. Remove outer bracket.
4. Remove door lock.
5. Remove door.
6. Remove ice chute.

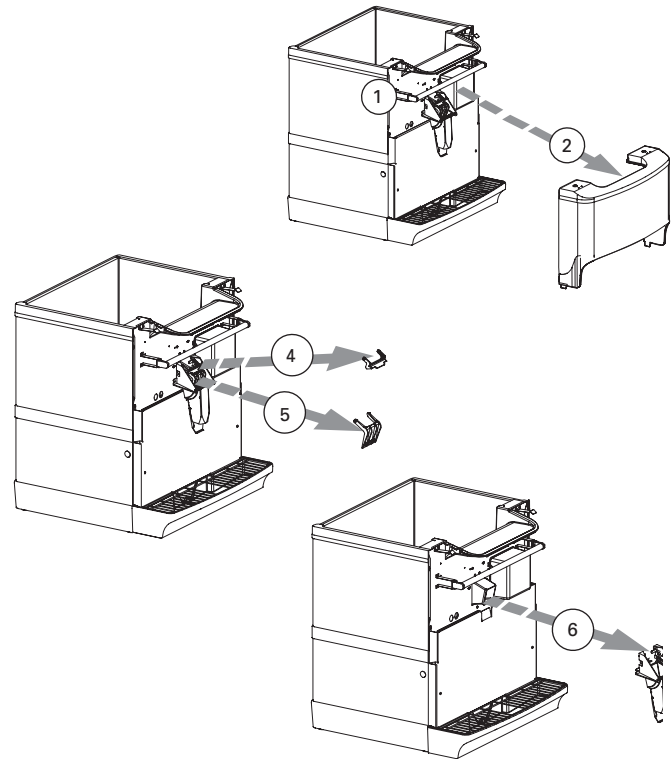

Ice Chute Removal

QUICKDRAW COMPONENTS

1. Turn the beverage valve switch on the front left side to the off position.



2. Place a receptacle (bucket or large cup) under the ice dispense chute.
3. Place the ice dispense switch to MANUAL mode. The door will open and ice will fall into the bucket or cup.
4. Remove the ice chute cover:
 - A. Grab the tabs on the back of chute and spread, pulling tabs off of pins.

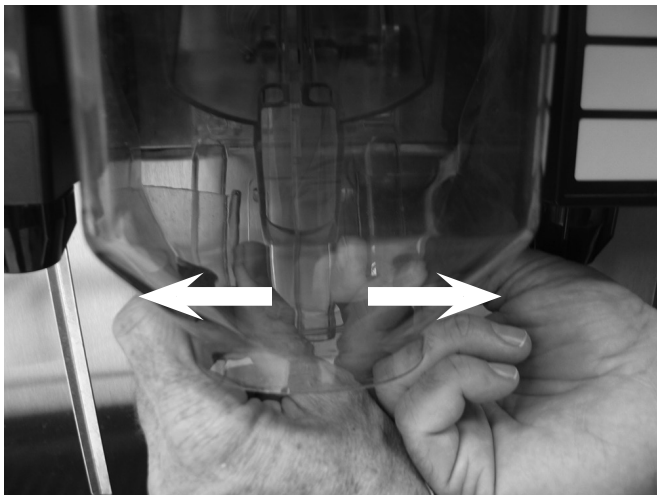

- B. Push the bottom of chute to rear until it stops.



- C. Rock the top of the chute forward until top of chute clears unit.

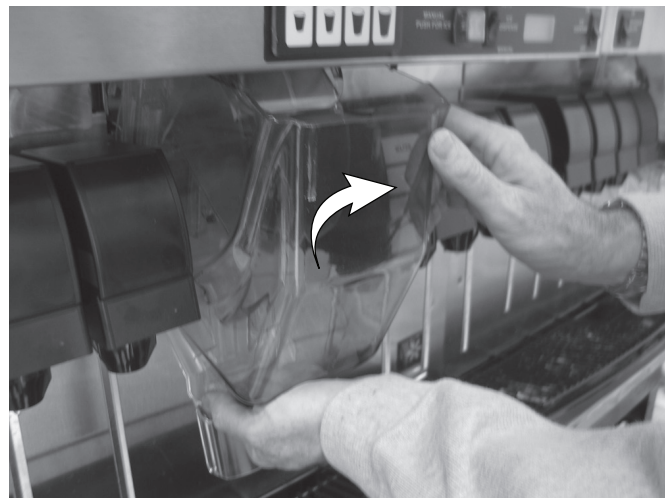

5. Mix a solution of mild detergent to clean the Quickdraw components. Using the detergent solution and a soft bristle brush or clean cloth, clean the following components:
 - Cup locator
 - Quickdraw chamber
 - Door
 - Ice chute cover
6. Rinse all parts in clean running water.
7. Mix a sanitizing solution of 1/4 ounce (7.5 mil) liquid, unscented bleach (5.25% CL NaO concentration) for each gallon (7.6 liters) of water. The mixture must provide 100-PPM available chlorine.

8. Using the sanitizing solution, a soft bristle brush, or a clean cloth, sanitize the components listed in Step 5. The ice chamber must be sanitized with a soft bristle brush to adequately clean the drainage area.
9. Reverse the procedure to reassemble the Quickdraw mechanism.
10. Place the ice dispense switch to the AUTO position, and place the beverage valve switch to the ON position.
11. Check for proper operation.

NON-FRONT SERVICEABLE GEAR MOTOR REMOVAL

These instructions are provided as a guide for the removal of the gear motor. Depending on the model number of your dispenser, these instructions may vary slightly.

1. Disconnect power from the electric receptacle.
2. Remove all ice from the ice storage bin of the dispenser.
3. Remove the paddle wheel pin from the paddle wheel agitator assembly inside the dispenser bin.

4. Remove the agitator assembly from the dispenser bin by pushing the agitator to the back of the bin. Angle the front of the agitator to the side. Pull the agitator forward then out of the dispenser.
5. Remove the paddle wheel from the dispenser by pulling the hub of the paddle wheel to the back of the bin and off the gear motor shaft.
6. Remove the splash panel from the dispenser and expose the gear motor.
7. Disconnect the electric connector from the gear motor wire leads.
8. Remove the pin in front of the gear motor.
9. You must be able to remove the gear motor from the dispenser.
10. To install a replacement gear motor, reverse this procedure.

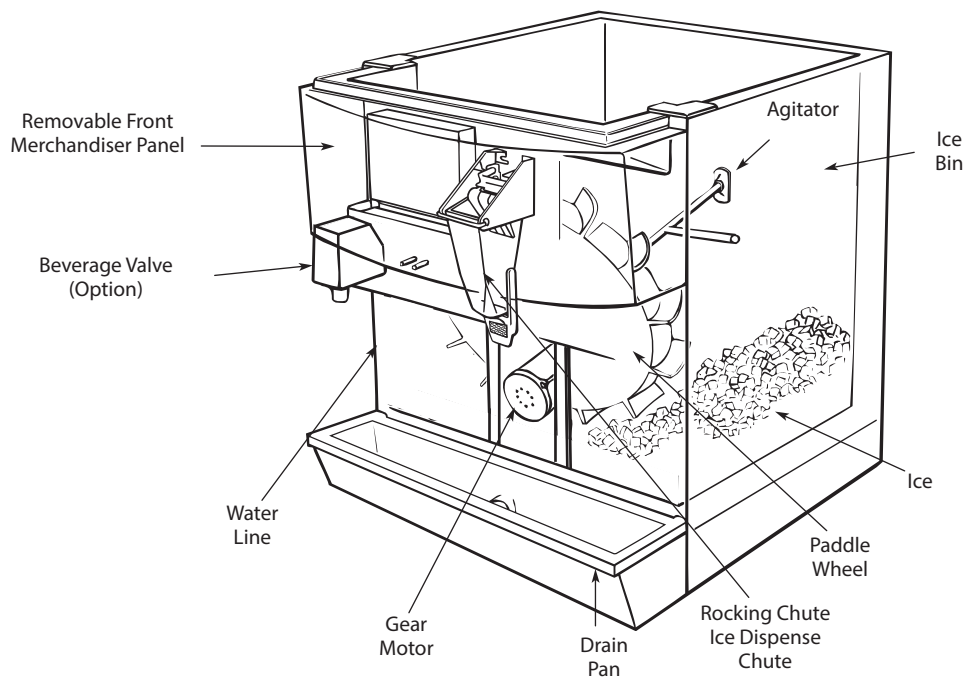

FRONT SERVICEABLE GEAR MOTOR REMOVAL

These instructions are provided as a guide for the removal of the gear motor. Depending on the model number of your dispenser, these instructions may vary slightly.

1. Unplug the dispenser.
2. Unplug the motor.
3. Remove motor mount pins.



4. Slide motor towards you.
5. Notice alignment of the chamfered edge of drive shaft.



6. New motor must have the same alignment (within 15 degrees).
7. To get correct alignment you can do one of two things:
 - a. Turn drive shaft with an adjustable wrench, being careful not to damage the drive shaft.
 - b. Plug in the unit, plug in the motor and use the ice dispense switch to move the drive shaft into correct alignment.
8. If you plugged in the unit to help with alignment of drive shaft now unplug the unit.
9. Slide motor up into housing, making sure that the tabs fit on the bracket.



10. Install motor mount pins.
11. Plug in motor.
12. Test unit.

Sanitizing

BEVERAGE SYSTEM CLEANING

⚠ Warning

Flush sanitizing solution from syrup system.

Residual sanitizing solution left in system could create a health hazard.

⚠ Warning

When using cleaning fluids or chemicals, rubber gloves and eye protection must be worn.

Sanitize the beverage system at initial start-up as well as regularly scheduled cleaning. The drain pan must be in place under soda valves, to carry away detergent and sanitizing agents that will be flushed through valves.

BAG-IN-BOX SYSTEM SANITATION

The procedure below is for the sanitation of one syrup circuit at a time. Repeat to sanitize additional circuits.

You will need the following items to clean and sanitize the Bag-in-Box (BIB) beverage system:

- Three (3) clean buckets
- Plastic brush or soft cloth
- Mild detergent
- Unscented bleach (5% Na CL O) or commercial sanitizer
- Bag-In-Box bag connector

1. Prepare the following in the buckets:
 - Bucket 1 — warm to hot tap water for rinsing.
 - Bucket 2 — mild detergent and warm to hot water.
 - Bucket 3 — mix a solution of unscented bleach (5% Na CL O) or commercial sanitizer and warm to hot water. Mixture must supply 100 PPM available chlorine (1/4 oz. [7.5 ml] bleach to 1 gallon [7.6 liters] water).

2. Disconnect the “syrup-line side” of the BIB connector.

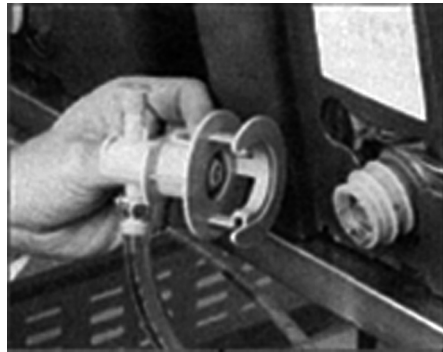

3. Rinse connector with warm tap water.
4. Connect syrup connector to BIB connector and immerse both into Bucket 1. A “bag-side” connector can be created by cutting the connector from an empty disposable syrup bag.

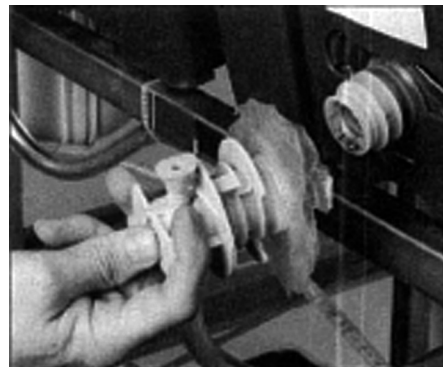
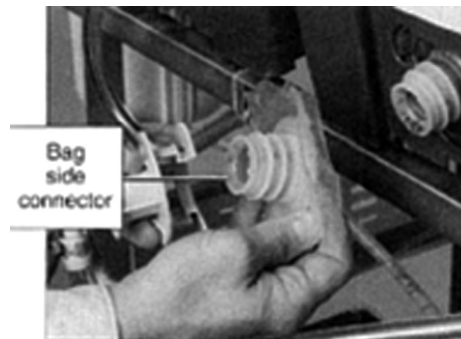

5. Draw rinse water through system until clean water is dispensed. Most beverage valves allow the syrup side to be manually activated by depressing the syrup pallet.
 6. Connect Bucket 2 to system.
 7. Draw detergent solution through system until solution is dispensed.
 8. Repeat steps 2-7 until all syrup circuits contain detergent solution.
 9. Allow detergent solution to remain in the system for 5 minutes.
 10. Connect Bucket 3 to system.
 11. Draw sanitizing solution through system until solution is dispensed.
 12. Repeat step 11 until all syrup circuits contain sanitizer solution.
 13. Allow sanitizer solution to remain in system for 15 minutes.
 14. Remove nozzles and diffusers from beverage valves.
 15. Scrub nozzles, diffusers and all removable valve parts (except electrical parts) with a plastic brush or a soft cloth and the detergent solution.
 16. Soak nozzles, diffusers and removable valve parts (except electrical parts) in sanitizer for 15 minutes.
 17. Replace nozzles, diffusers and valve parts.
 18. Connect Bucket 1 to system.
 19. Draw rinse water through system until no presence of sanitizer is detected.
 20. Attach syrup connectors to BIBs.
 21. Draw syrup through system until only syrup is dispensed.
 22. Discard first 2 drinks.
2. Disconnect all product and water lines from product tanks and remove carbonator.
 3. Locate the Figal syrup tank for the circuit to be sanitized. Remove both quick disconnects from the Figal syrup tank. Rinse quick disconnects in tap water.
 4. Connect rinse tank to the syrup line. Draw clean rinse water through the valve until syrup is flushed from the system.
 5. Connect detergent tank to the syrup line and draw detergent through the valve for two minutes. Then, allow remaining detergent to stay in the system for five minutes.
 6. Connect rinse tank to the syrup line. Draw clean rinse water through the valve until detergent is flushed from the system.
 7. Remove valve nozzle and diffuser as shown in Daily Cleaning instructions. Using a plastic brush or a soft cloth and warm water, scrub the nozzle, diffuser, bottom of the dispensing valve and cup lever, if applicable.
 8. Place removable valve parts (EXCEPT solenoids) in sanitizing solution for 15 minutes.
 9. Replace valve diffuser and nozzle on the beverage valve.
 10. Connect sanitizer tank to the syrup line and draw sanitizer through the valve for two minutes. Allow sanitizer to remain in the system for a minimum of 15 minutes.
 11. Reconnect syrup and carbonated water lines.
 12. Draw syrup through the lines to rinse the system. Discard drinks until at least two cups of satisfactory tasting beverage are dispensed through the valve.

FIGAL BEVERAGE SYSTEM

1. Prepare the following in three clean Figal tanks:
 - Rinse tank - fill with room temperature tap water.
 - Detergent tank - mix approved beverage system cleaner with warm water as directed.
 - Sanitizing tank - mix a solution of unscented bleach (5% Na CL O) or commercial sanitizer and warm to hot water. Mixture must supply 100 PPM available chlorine (1/4 oz. [7.5 ml] bleach to 1 gallon [7.6 liters] water).

Shipping, Storage and Relocation

Caution

Before shipping, storing, or relocating this unit, syrup systems must be sanitized. After sanitizing, all liquids (sanitizing solution and water) must be purged from the unit. A freezing environment causes residual sanitizing solution or water remaining inside the unit to freeze, resulting in damage to internal components.

THIS PAGE INTENTIONALLY LEFT BLANK

Section 5 Troubleshooting

Checklist

If a problem arises during operation of your dispenser, follow the checklist below before calling service. Routine adjustments and maintenance procedures are not covered by the warranty.

Problem	Possible Cause	To Correct
Dispenser will not dispense ice (and NO SOUNDS are heard when machine is activated).	No power.	Check electrical connection.
	Loose wire in electrical system.	Thoroughly check all wire connections.
	Dispenser overloaded with ice.	Remove ice from dispenser until unit will operate.
	Motor not working.	Check thermally protected motor. Replace motor or capacitor if necessary.
Dispenser will not dispense ice (motor runs but no ice movement is heard in bin).	No ice in bin.	Fill dispenser with ice.
	Door not opening.	Check rocking chute mechanism or electric solenoid operation.
	Paddle wheel pin slipped from the paddle wheel.	Replace paddle wheel pin.
Excessive clustering or bridging of ice.	Loaded ice not broken up. (Caution: Super cooled ice is not covered by the Servend warranty.)	Break ice clusters before manually filling the dispenser. (See ice recommendations.)
	Excessive water spilling from the ice machine.	Adjust ice machine to eliminate water spillage.
	Poorly adjusted ice machine.	Adjust ice machine to eliminate large waffle shapes.
	Extremely low usage of the dispenser.	Lower the ice level in the bin.
Ice dispenses continuously.	Misaligned microswitch.	Adjust microswitch.
	Agitation timer set incorrectly.	Test agitation timer.
Thumping noise or irregular sound at a particular area of the dispenser.	Shaved ice clusters in the bin.	Remove clusters, discover why ice is shaving, and then repair.
Dispensing crushed ice or reduced dispensing speed.	Water spillage from ice machine into dispenser bin.	Adjust ice machine.
	Agitation timer.	Test agitation timer.
	Bridge of ice sheet is too thick.	Adjust ice machine.
	Paddle wheel area broken or cracked.	Replace paddle wheel area.
	Ice clusters in bin.	Break up or remove clusters.
	Door not fully open.	Adjust door.
Door will not close.	Ice jammed in chute.	Adjust bridge in ice machine or, when manually filling, break up clusters.
	Door and/or door lock has come out of place.	Replace door and lock into proper position.
Mounting brackets for rocking chute have spread too far apart.		Bend parts into shape.

Drink Troubleshooting

Condition	Investigation	Check	Correction
Water only dispensing	No pressure	Regulator(s) out of adjustment	Check/adjust regulator(s).
		Out of CO ₂	Install fresh tank.
		Defective regulator(s)	Check/repair/replace regulator(s).
		CO ₂ line pinched, kinked or obstructed	Check/repair/replace CO ₂ line.
Syrup and CO ₂ only dispensing	Carbonator	No power	Check power supply. Plug in carbonator or reset breaker.
		Water supply	Make sure water is turned "on".
			Replace water filter.
			Check/clean/replace pump strainer.
			Check/clean/repair water check valve.
		Check for frozen water line. Internal carbonator unit only.	
Defective carbonator	Check/repair/replace carbonator pump, motor, electrode or liquid level control.		
Syrup and plain water only dispensing	No pressure	Out of CO ₂	Install fresh tank.
		HP regulator out of adjustment	Adjust HP regulator to the proper setting.
		Defective HP regulator	Check/repair/replace HP regulator.
		CO ₂ line pinched, kinked or obstructed	Check/repair/replace CO ₂ line.
One valve will not dispense anything	Is there power to the valve?	Broken wire or loose connection	Replace/repair wire or connector.
		Bad microswitch	Replace microswitch.
Beverage dispensed is too sweet	Is the ratio (brix) of the drink correct?	Flow control out of adjustment	Adjust the flow control.
		Insufficient soda flow due to low carbonator pressure	Adjust CO ₂ pressure or change the tank.
		Low CO ₂ pressure due to leaks	Repair CO ₂ leaks.
		Obstruction in the water or soda line	Clean out the lines.
Beverage is not sweet enough	Is the ratio (brix) of the drink correct?	Flow control out of adjustment	Adjust the flow control.
		Soda flow too high	Reset CO ₂ pressure or replace regulator if necessary.
		Obstruction in syrup line	Clean out the syrup line.
Drinks are foaming	Are system pressures correct?	Over carbonation	Check CO ₂ supply. Reset pressure or replace regulator if necessary.
		Dirty lines/valves	Clean/sanitize entire system.

Condition	Investigation	Check	Correction
No water, syrup or gas dispensing	Is there power to the unit?	No power	Plug in unit or reset breaker.
		Power to control box	Replace fuse or control box.
	Is power coming through the key switch?	Key switch "off"	Turn switch "on".
		Key switch defective	Replace key switch.
	Is there power to the key switch?	No power through the transformer	Reset/replace transformer.

Pump Troubleshooting

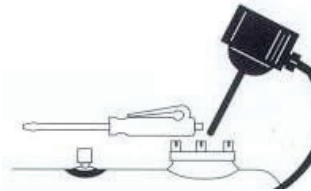
Problem	Possible Cause	To Correct
Pump motor does not shut off	Problem with probe or probe harness	<ol style="list-style-type: none"> 1. Remove probe electronics. 2. Pass magnetic tip of screwdriver by lower end of tube extending from electronics package. 3. Reed switch will close 4. Carbonator operates. 
Pump motor intermittent	Problem with probe or probe harness	
Pump motor does not pump	Water pressure from water source is not high enough	

Quickdraw Mechanism Troubleshooting

Problem	Possible Cause	To Correct
Ice dispense door is not closing	CO ₂ supply is low.	Replenish CO ₂ supply.
	CO ₂ regulator set too low.	Check regulator setting and adjust to 40 - 45 psig.
	Toggle switch is in the OFF or MANUAL position.	Move toggle switch to the AUTO position.
	Power is disconnected from unit.	Plug unit in.
Ice portion size is increasing	CO ₂ supply is low.	Replenish CO ₂ supply.
	CO ₂ regulator set too low.	Check regulator setting and adjust to 40 - 45 psig.
	Sensor board and main board are not communicating properly.	Check main board/sensor board communication process.
Ice portion size is erratic	Sensor board and main board are not communicating properly.	Check main board/sensor board communication process.

Quickdraw Ice Portion Control Program

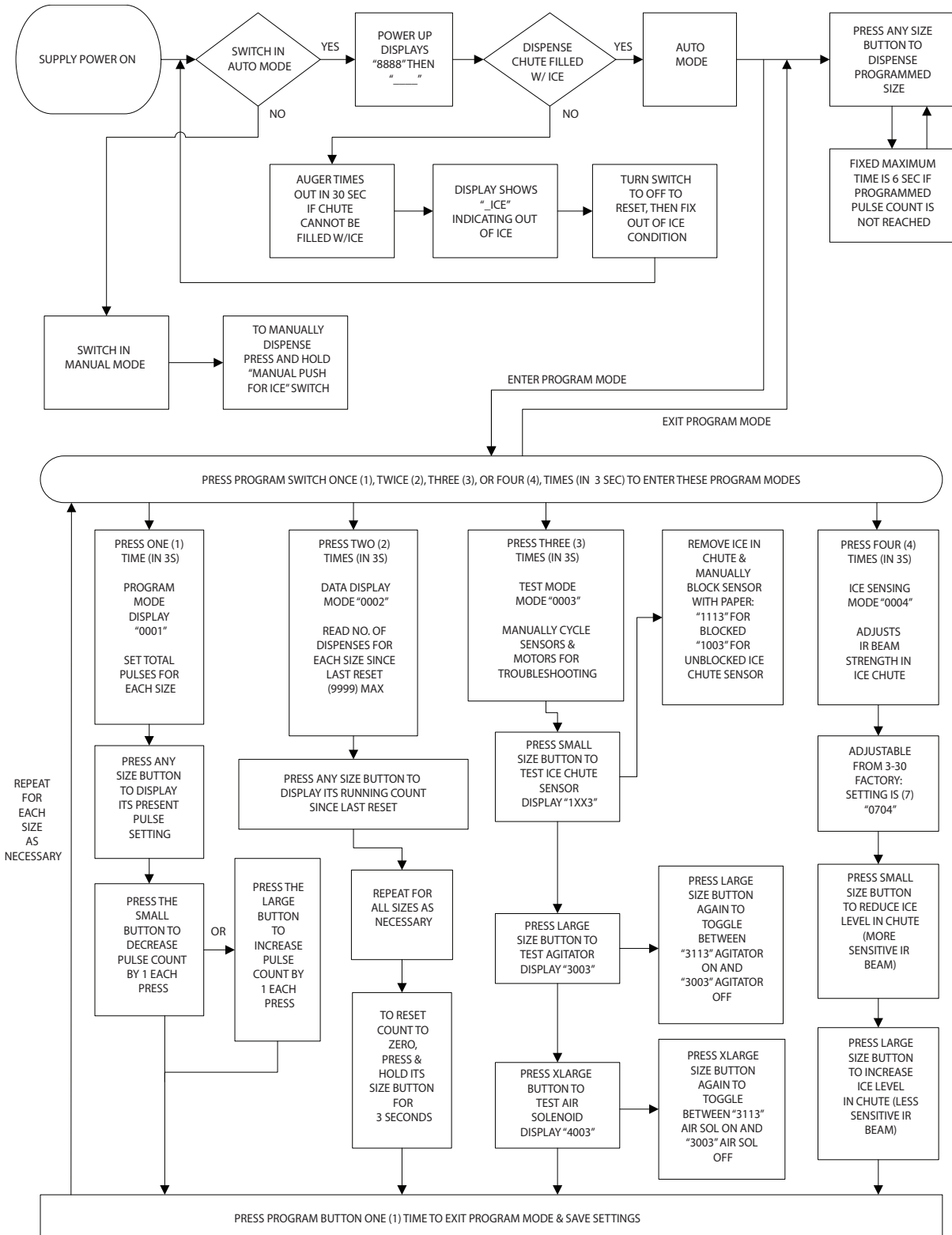



SERVEND
2100 FUTURE, SELLERSBURG, IN 47172

800-367-4233
WWW.MANITOWOCBEVERAGE.COM/US

Every new piece of Manitowoc Foodservice equipment comes with KitchenCare™ and you choose the level of service that meets your operational needs from one restaurant to multiple locations.

StarCare – Warranty & lifetime service, certified OEM parts, global parts inventory, performance audited

ExtraCare – CareCode, 24/7 Support, online/mobile product information

LifeCare – Install & equipment orientation, planned maintenance, KitchenConnect™, MenuConnect

Talk with KitchenCare™ • 1-844-724-CARE • www.mtwkitchencare.com



To learn how Manitowoc Foodservice and its leading brands can equip you, visit our global web site at www.manitowocfoodservice.com, then discover the regional or local resources available to you.

