

# **SERVICE MANUAL**



## **Model C712 & C713 Soft Serve Freezers**

**Original Service Instructions**

**062179-S**

**6/15/05 (Original Publication)  
(Updated 7/31/2018)**

**CAUTION:** Information in this manual is intended to be used by authorized Taylor service technicians only.

**Note:** *Continuing research results in steady improvements; therefore, information in this manual is subject to change without notice.*

**Note:** *Only instructions originating from the factory or its authorized translation representative(s) are considered to be the original set of instructions.*

© June, 2005 Taylor Company  
(Updated 7/31/2018)  
062179-S

Any unauthorized reproduction, disclosure, or distribution of copies by any person of any portion of this work may be a violation of Copyright Law of the United States of America and other countries, could result in the awarding of Statutory Damages of up to \$250,000 (17 USC 504) for infringement, and may result in further civil and criminal penalties.

All rights reserved.



Taylor Company  
750 N. Blackhawk Blvd.  
Rockton, IL 61072

---

## Section 1: Introduction

Safety . . . . .	1-2
Model C712 Specifications . . . . .	1-4
Model C713 Specifications . . . . .	1-6
Running Specifications . . . . .	1-8
General Installation Instructions . . . . .	1-9
Environmental Notices . . . . .	1-13
User Interface . . . . .	1-15

## Section 2: Controls

Universal Control Programming . . . . .	2-2
Power Interrupt . . . . .	2-13
Pump Operation . . . . .	2-14
Timers . . . . .	2-15
Beater Stir Cycles . . . . .	2-16
Setting Viscosity . . . . .	2-17
Jumper Pin Charts . . . . .	2-18
Control Overview - UVC4 . . . . .	2-20
Universal Control Board - UVC4 . . . . .	2-21
C712/C713 UVC4 Update Instructions . . . . .	2-25
Refrigeration Schematic . . . . .	2-26
Refrigeration System Components . . . . .	2-27

## Section 3: Troubleshooting

General Troubleshooting Guide . . . . .	3-2
Electrical Troubleshooting Guide . . . . .	3-5
C712/C713 Electrical Troubleshooting Guide . . . . .	3-6
Pump Style Freezer Troubleshooting . . . . .	3-7
Bacteria Troubleshooting . . . . .	3-8

## Section 4: Parts

Parts Warranty Explanation . . . . .	4-2
Model C712 Exploded View . . . . .	4-3
Operator Parts (Model C712) . . . . .	4-6
Model C713 Exploded View . . . . .	4-8
Operator Parts (Model C713) . . . . .	4-11
Control A. - X67560-27 (Model C712). . . . .	4-13
Control A. - X67561-27-(Model C713) . . . . .	4-15
Box A.-Cap & Relay - X6540227SP - (Model C712 & C713/Bristol). . . . .	4-17
Box A.-Cap & Relay - X81081-27 (Model C713/Copeland) . . . . .	4-18
Pump A.-Mix Simplified - X57029- (Model C712) . . . . .	4-19
Door and Beater Assembly (Model C712) . . . . .	4-20

# Table of Contents

---

Door and Beater Assembly (Model C713) . . . . .	4-21
Plate A.-Dec (Model C712). . . . .	4-22
Plate A.-Dec (Model C713). . . . .	4-23
Rail-Syrup - X63883-27 (Optional) . . . . .	4-24
Switch A.-Dual Lever - X69838 (Model C712 & C713). . . . .	4-25
Actuator A.-Draw Switch - X69835 (Model C712 & C713) . . . . .	4-26
Blower A. X53725-27 (Model C712 & C713) . . . . .	4-27
Condenser A. - X68077-27G (Model C712 & C713) . . . . .	4-28
Accessories . . . . .	4-29
Brushes (Model C712 & C713). . . . .	4-30

## Section 5: Parts List

## Section 6: Wiring Diagrams

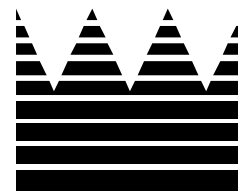

## **Section 1: Introduction**

- **Safety**
- **Model C712 Specifications**
- **Model C713 Specifications**
- **Running Specifications**
- **General Installation Instructions**
- **User Interface**
- **User Interface**

## Safety

We at Taylor Company are committed to manufacturing safe operating and serviceable machines. The many built-in safety features that are part of all Taylor machines are aimed at protecting operators and trained service technicians alike.

**1** This manual is intended exclusively for Taylor authorized service personnel.

Per IEC 60335-1 and its part 2 standards, "This appliance is to be used only by trained personnel. It is not intended for use by children or people with reduced physical, sensory, or mental capabilities, or lack of experience and knowledge, unless given supervision or instruction concerning the use of the appliance by a person responsible for their safety."



**NOTICE!** This manual is intended exclusively for authorized Taylor service personnel.



**CAUTION! DO NOT** attempt to run the machine unless you have been properly trained to do so. Failure to do so can result in personal injury or machine damage.



**WARNING!** This machine must be properly grounded! **DO NOT** operate this machine unless it is properly grounded and all service panels and access doors are restrained with screws. Failure to do so can result in severe personal injury from electrical shock!



**WARNING!** Avoid injury.

- **DO NOT** attempt any repairs unless the main power supply to the machine has been disconnected.
- **DO NOT** operate the machine with larger fuses than specified on the data label.
- Stationary machines which are not equipped with a power cord and plug or other device to disconnect the machine from the power source must have an all-pole disconnecting device with a contact gap of at least 0.125 in. (3 mm) installed in the external installation.
- Machines that are permanently connected to fixed wiring and for which leakage currents may exceed 10 mA, particularly when disconnected, not used for long periods, or during initial installation, shall have protective devices to protect against the leakage of current, such as a GFI, and be installed by authorized personnel to the local codes.
- Supply cords used with this machine shall be oil-resistant, sheathed flexible cable, not lighter than ordinary polychloroprene or other equivalent synthetic elastomer-sheathed cord (code designation 60245 IEC 57) installed with the proper cord anchorage to relieve conductors from strain, including twisting, at the terminals and protect the insulation of the conductors from abrasion.
- **For Cord-Connected Machines:** Only authorized Taylor service technicians may install a plug on this machine.

Failure to follow these instructions may result in electrocution or damage to the machine.



**IMPORTANT!** This machine is provided with an equipotential grounding lug that is to be properly attached to the rear of the frame by the authorized installer. The installation location is marked by the equipotential bonding symbol (5021 of IEC 60417-1) on the removable panel and the frame.



**CAUTION! DO NOT** remove the machine door or any internal operating parts (examples: beater, scraper blades, etc.) unless all control switches are in the OFF position. Failure to follow these instructions may result in severe personal injury from hazardous moving parts.



**WARNING!** This machine has many sharp edges that can cause severe injuries.

**Examples:**

- Scraper blades
- Condenser fins
- Cup/cone dispenser (if applicable)



**CAUTION!** This machine must be installed on a level surface to avoid the hazard of tipping. Extreme care should be taken in moving this machine for any reason. Two or more persons are required to safely move this machine. Failure to comply may result in personal injury or machine damage.



**WARNING!** Only install this machine in a location where its use and maintenance is restricted to trained personnel. Failure to comply may result in personal injury.



**WARNING!** This machine must **NOT** be installed in an area where a water jet or hose can be used. **NEVER** use a water jet or hose to rinse or clean the machine. Failure to follow this instruction may result in electrocution.



**NOTICE!** Cleaning and sanitizing schedules are governed by your federal, state, or local regulatory agencies and must be followed accordingly. Please see the cleaning section of this manual for the proper procedure to clean this machine.

**Important!** Authorized service personnel must ensure that the proper personal protective equipment (PPE) is available and worn when required during installation and service.



**IMPORTANT!** Access to the service area of the machine is restricted to persons having knowledge and practical experience with the machine, in particular as far as safety and hygiene are concerned.

# Model C712 Specifications

## Freezing Cylinder

Two, 3.4 qt. (3.2 L)

## Mix Hopper

Two, 20 qt. (18.9 L)

## Beater Motor

Two, 1.5 hp

## Refrigeration Machine

Two, approximately 9,500 BTU/hr compressors  
Refrigerant R404A.

## Electrical

Table 1-1

Electrical	Maximum Fuse Size		Minimum Circuit Ampacity	
	Left	Right	Left	Right
208-230/60/1 Air	35	35	27	25
208-230/60/1 Air, Syrup	40	35	28	25
208-230/60/1 Water	35	35	26	25
208-230/60/3 Air	25	20	19	17
208-230/60/3 Water	25	20	18	17
220-240/50/1 Water	30	25	22	20
380-415/50/3N~Air	12	10	11	9

This machine may be manufactured in other electrical characteristics. Refer to the local Taylor distributor for availability. (For exact electrical information, always see the data label of the machine.)

## Air-Cooled

Clearance: A minimum of 3 in. (76 mm) is required around all sides. Install the deflector provided to prevent recirculation of warm air.

## Water-Cooled

Water inlet and drain connections under the side of the base, 1/2 in. FPT.

## Dimensions

Width: 25-7/16 in. (646 mm)  
Height: 60 in. (1524 mm)  
Depth: 36-3/16 in. (919 mm)  
Floor Clearance\*: 4-3/4 in. (121 mm)  
*\*Mounted on standard casters*

## Approximate Weights

Net: 777 lbs. (352 kgs)  
Crated: 855 lbs. (388 kgs)  
Volume: 68.4 cu. ft. (1.94 cu m)



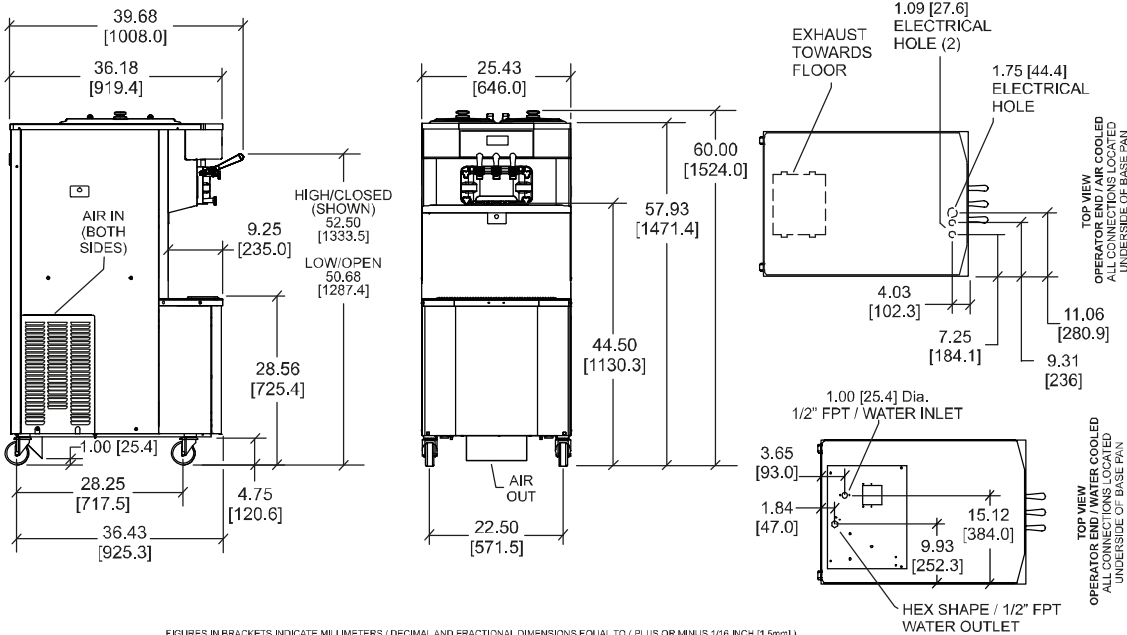

FIGURES IN BRACKETS INDICATE MILLIMETERS / DECIMAL AND FRACTIONAL DIMENSIONS EQUAL TO ( PLUS OR MINUS 1/16 INCH [1.5mm] ).

Figure 1-1

1

# Model C713 Specifications

## Freezing Cylinder

Two, 3.4 qt. (3.2 L)

## Mix Hopper

Two, 20 qt. (18.9 L)

## Beater Motor

Two, 1.5 hp

## Refrigeration Machine

Two, approximately 9,500 BTU/hr compressors  
Refrigerant R404A.

## Electrical

Table 1-2

Electrical	Maximum Fuse Size		Minimum Circuit Ampacity	
	Left	Right	Left	Right
208-230/60/1 Air	35	35	25	23
208-230/60/1 Air, Syrup	35	35	26	23
208-230/60/1 Water	35	35	25	23
208-230/60/3 Air	25	25	19	17
208-230/60/3 Water	20	20	17	15
220-240/50/1 Water	25	25	21	19
380-415/50/3N~Air	12	10	9	8

This machine may be manufactured in other electrical characteristics. Refer to the local Taylor distributor for availability. (For exact electrical information, always see the data label of the machine.)

## Air-Cooled

Clearance: A minimum of 3 in. (76 mm) is required around all sides. Install the deflector provided to prevent recirculation of warm air.

## Water-Cooled

Water inlet and drain connections under the side of the base, 1/2 in. FPT.

## Dimensions

Width: 25-7/16 in. (646 mm)  
Height: 60 in. (1524 mm)  
Depth: 36-3/16 in. (919 mm)  
Floor Clearance\*: 4-3/4 in. (121 mm)  
*\*Mounted on standard casters*

## Approximate Weights

Net: 733 lbs. (333 kgs)  
Crated: 810 lbs. (367 kgs)  
Volume: 67.5 cu. ft. (1.91 cu m)

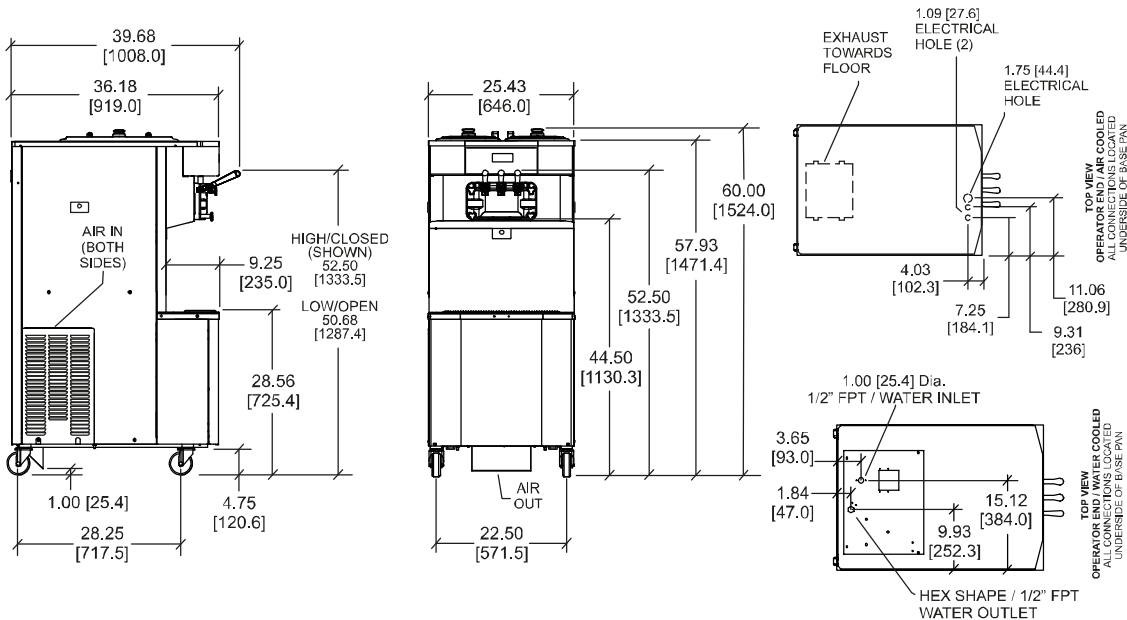

Figure 1-2

# Running Specifications

## Pressures/Temperatures

The following are the Taylor recommended settings for various components within these models. The freezers in this manual use refrigerant R404A.

1

### Expansion Valve (AXV)

Air-Cooled - 21 psi (145 kPa)

Water-Cooled - 21 psi (145 kPa)

for a normal product of 16°F to 18°F (-8.8°C to -7.7°C)

### Expansion Valve Adjustment (AXV)

Place your gauge on the access valve on the suction line (located at the compressor).

Adjust the pressure higher or lower by turning the adjustment screw. Clockwise turns raise the pressure and counterclockwise turns lower the pressure.

**Note:** Make expansion valve adjustments with mix in the cylinder and the freezer in the Auto mode. Be sure to allow adequate time for the pressure to stabilize.

### Low Side (Suction)

Suction pressure equals expansion valve setting.

### High Side (Discharge)

High side pressure varies for air-cooled machines, depending on the ambient temperature.

Table 1-3

Ambient Temperature		Normal Operating Head Pressures
F	C	PSI
70°	21.1°	240–270 (1,655 kPa–1,862 kPa.)
80°	26.7°	270–300 (1,862 kPa–2,069 kPa.)
90°	32.2°	300–340 (2,069 kPa–2,344 kPa.)
100°	37.8°	340–380 (2,344 kPa–2,620 kPa.)

### Water Valve

On a water-cooled machine, the water valve should be set to maintain a compressor head pressure of 255 psi (1,758 kPa).

### Water Valve Adjustment

Place your gauge on the high side access port of the compressor. Turning the adjustment stem on the water valve clockwise will lower the pressure.

**Note:** Make this adjustment with mix in the cylinder and the freezer in the Auto mode. Make sure to allow adequate time for the pressure to stabilize.

## General Installation Instructions

**NOTICE!** Only trained, authorized service technicians should install this machine. Failure to comply will void the factory warranty.

The following are general installation instructions. For complete installation details, please see the checkout card.



**IMPORTANT!** All wiring and plumbing must conform to national and local codes.

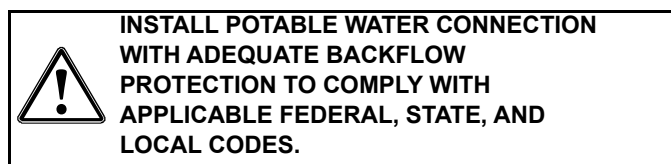

### Site Preparation

Review the area where the machine is to be installed before uncrating the machine. Make sure that all possible hazards to the user and the equipment have been addressed.

### Clearance: Air-Cooled Machines

This machine requires a minimum of 3 in. (76 mm) air clearance around all sides.

**DO NOT** obstruct air intake and discharge openings. Install the deflector provided to prevent recirculation of warm air.

Failure to allow proper clearance and airflow may cause poor freezer performance and damage to the machine.

**For Indoor Use Only:** This machine is designed to operate indoors, under normal ambient temperatures of 70°F to 75°F (21°C to 24°C). The freezer has successfully performed in high ambient temperatures of 104°F (40°C) at reduced capacities.



**WARNING!** This machine must **NOT** be installed in an area where a water jet or hose can be used. Never use a water jet or hose to rinse or clean this machine. Using a water jet or hose on or around this machine may result in the electrocution of the user or damage to the machine.



**CAUTION!** This machine must be installed on a level surface to avoid the hazard of tipping. Extreme care should be taken in moving this machine for any reason. Two or more persons are required to safely move this machine. Failure to comply may result in personal injury or machine damage.

Uncrate the machine. Inspect the machine for damage. Report any damage to the Taylor factory immediately.

This machine is made in the USA and has USA sizes of hardware. All metric conversions are approximate and vary in size.

### Installer Safety



**IMPORTANT!** In all areas of the world, the machine should be installed in accordance with existing local codes. Please contact your local authorities if you have any questions.

Care should be taken to ensure that all basic safety practices are followed during the installation and servicing activities related to the installation and service of Taylor machines.

- Only authorized Taylor service personnel should perform installation and repairs on the machine.
- Authorized service personnel should consult OSHA Standard 29CFR1910.147 or the applicable code of the local area for the industry standards on lockout/tagout procedures before beginning any installation or repairs.

## INTRODUCTION

- Authorized service personnel must ensure that the proper personal protective equipment (PPE) is available and worn when required during installation and service.
- Authorized service personnel must remove all metal jewelry, rings, and watches before working on electrical equipment.

1



**WARNING!** This machine has many sharp edges that can cause severe injuries.

### Examples:

- Scraper blades
- Condenser fins
- Cup/cone dispenser (if applicable)

## Electrical Connections



**IMPORTANT!** In the United States, this machine is intended to be installed in accordance with the National Electrical Code (NEC), ANSI/NFPA 701987. The purpose of the NEC code is the practical safeguarding of persons and property from hazards arising from the use of electricity. This code contains provisions considered necessary for safety.

In all other areas of the world, the machine should be installed in accordance with the existing local codes. Please contact your local authorities if you have any questions.

Each machine requires one power supply for each data label on the machine. Check the data label(s) on the machine for branch circuit overcurrent protection or fuse, circuit ampacity, and other electrical specifications.

See the wiring diagram provided inside the electrical box for proper power connections.



**FOLLOW YOUR LOCAL ELECTRICAL CODES.**



**WARNING!** This machine must be properly grounded! Failure to do so can result in severe personal injury from electrical shock!



**IMPORTANT!** This machine is provided with an equipotential grounding lug that is to be properly attached to the rear of the frame by the authorized installer. The installation location is marked by the equipotential bonding symbol (5021 of IEC 60417-1) on the removable panel and the frame.



**WARNING!** Avoid injury.

- **DO NOT** attempt any repairs unless the main power supply to the machine has been disconnected.
- **DO NOT** operate the machine with larger fuses than specified on the data label.
- Stationary machines which are not equipped with a power cord and plug or other device to disconnect the machine from the power source must have an all-pole disconnecting device with a contact gap of at least 0.125 in. (3 mm) installed in the external installation.
- Machines that are permanently connected to fixed wiring and for which leakage currents may exceed 10 mA, particularly when disconnected, not used for long periods, or during initial installation, shall have protective devices to protect against the leakage of current, such as a GFI, and be installed by authorized personnel to the local codes.
- Supply cords used with this machine shall be oil-resistant, sheathed flexible cable, not lighter than ordinary polychloroprene or other equivalent synthetic elastomer-sheathed cord (code designation 60245 IEC 57) installed with the proper cord anchorage to relieve conductors from strain, including twisting, at the terminals and protect the insulation of the conductors from abrasion.
- **For Cord-Connected Machines:** Only authorized Taylor service technicians may install a plug on this machine.

Failure to follow these instructions may result in electrocution or equipment damage.

## Disconnect Switch

If the machine has no plug, a separate disconnect switch must be installed, or another alternate means to disconnect power must be implemented.

## Water Connections

### Water-Cooled Machines, Only

An adequate cold water supply must be provided with a hand shut-off valve. The water inlet and drain connections are located on the right side or the underside of the base. These connections are either 3/8 in. or 1/2 in. FTP, depending on the model of the machine. (Refer to "Model Specifications.")

Flexible lines are recommended, if local codes permit. In Europe, hose sets for connection of appliances to the water mains must comply to the International IEC 61770 standard.

The water expansion valve setting should be set at 255 PSIG (1758 kPa).

Depending on local water conditions, it may be advisable to install a water strainer to prevent foreign substances from clogging the automatic water valve. There will be only one water **in** and one water **out** connection.

**DO NOT** install a hand shutoff valve on the water **out** line. Water should always flow in this order: First, through the automatic water valve; second, through the condenser; and third, through the outlet fitting to an **open trap drain**.



**IMPORTANT!** A backflow prevention device is required on the incoming water connection side. Please see the applicable national, state, and local codes for determining the proper configuration.

## Refrigeration



**CAUTION!** In consideration of our environment, Taylor uses only earth-friendly HFC refrigerants. The HFC refrigerant used in this machine is R404A. This refrigerant is generally considered nontoxic and nonflammable, with an ozone-depleting potential (ODP) of zero (0). However, any gas under pressure is potentially hazardous and must be handled with caution.

**NEVER** fill any refrigerant cylinder completely with liquid. Filling the cylinder to approximately 80% will allow for normal expansion.



**CAUTION!** Use only R404A refrigerant that conforms to the AHRI standard 700 specification. The use of any other refrigerant may expose users and operators to unexpected safety hazards.



**WARNING!** Refrigerant liquid sprayed onto the skin may cause serious damage to tissue. Keep eyes and skin protected. If refrigerant burns should occur, flush the area immediately with cold water. If burns are severe, apply ice packs and contact a physician immediately.



**NOTICE!** Taylor reminds technicians to be aware of government laws regarding refrigerant recovery, recycling, and reclaiming systems. If you have any questions regarding these laws, please contact the factory service department.



**IMPORTANT!** R404A refrigerant used in conjunction with polyolester oils is extremely moisture absorbent. When opening a refrigeration system, the maximum time the system is open must not exceed 15 minutes.

Cap all open tubing to prevent humid air or water from being absorbed by the oil.

1

### Main Compressor:

Air-cooled machines: 40 oz. (1,134 g) of R404A.

Water-cooled machines: 38 oz. (1,077 g) of R404A.

### Gear Alignment and Rear Shell Bearing

1. Make sure the drive shaft(s) can easily slide in and out of the female socket on the gear unit(s).
2. If a drive shaft is binding, the gear unit could be out of alignment (loose). Check the bolts on the gear unit to make sure they are tight.
3. Inspect the rear shell bearing for tightness. Make sure the locking tab has been folded over to prevent the nut from loosening.

### Beater Rotation



**NOTICE!** Beater rotation must be clockwise as viewed looking into the freezing cylinder.



**DANGER!** The main power supply(s) to the machine must be disconnected prior to performing any repairs. Failure to follow this instruction may result in personal injury or death from electrical shock or hazardous moving parts, as well as poor performance or damage to the machine.

1. Remove the door assembly, beater, and scraper blades.
2. Place a magnet over the door switch in the front panel. This deactivates the safety feature, which prevents the operation of the machine when the door is not installed.

3. Place the power switch in the ON position.
4. Press the Wash symbol. This activates the beater motor only.
5. Look into the freezing cylinder. The drive shaft should be turning clockwise.
6. Press the Wash symbol again to stop the beater motor.

To correct rotation on a single-phase machine, exchange leads inside the beater motor. (Follow the diagram printed on the motor.)

To correct rotation on a three-phase machine, interchange any two incoming power supply lines at freezer main terminal block only.



**DANGER!** The main power supply(s) to the machine must be disconnected prior to performing any repairs. Failure to follow this instruction may result in personal injury or death from electrical shock or hazardous moving parts, as well as poor performance or damage to the machine.

### Pump Motor Rotation (C712 Only)

1. Remove the air/mix pump assembly.
2. Connect power to the freezer and place the power switch in the ON position.
3. Press the Mix Pump button. This will activate the pump motor only.
4. Observe the pump ball crank. It should be rotating counterclockwise.

If rotation is not correct, see the wiring diagram on the pump motor and re-wire accordingly.



**DANGER!** The main power supply(s) to the machine must be disconnected prior to performing any repairs. Failure to follow this instruction may result in personal injury or death from electrical shock or hazardous moving parts, as well as poor performance or damage to the machine.



## Syrup Rail Operating Instructions

1. Remove the stainless steel syrup jar with topping pump from the syrup rail. Check the water level in the well. Make sure the water is filled to the indicating mark on the inside wall (16 oz. [454 g]). Check the water level daily.
2. Place the heater switch in the ON position. The heating process will take approximately 1-1/4 hours.
3. Prepare a pail with an approved 100 PPM sanitizing solution.

**Important!** Use warm water and follow the manufacturer's specifications.

4. Sanitize the pump by placing the entire assembly in the solution and pump the solution through the pump until sanitized.
5. Fill the heated and room temperature syrup jars with toppings. Place the topping pump in the heated syrup jar. Sanitize the ladle and place it in the room temperature jar.



**IMPORTANT!** If the crossed-out waste container symbol is affixed to this product, it signifies that this product is compliant with the EU Directive as well as other similar legislation in effect after August 13, 2005. Therefore, it must be collected separately after its use is completed, and cannot be disposed as unsorted municipal waste.

The user is responsible for delivering the product to the appropriate collection facility, as specified by your local code.

For additional information regarding applicable local laws, please contact the municipal facility and/or local distributor.

**NOISE LEVEL:** Airborne noise emission does not exceed 78 dB(A) when measured at a distance of 1.0 meter from the surface of the machine at a height of 1.6 meters from the floor.

## Environmental Notices



**CAUTION!** In consideration of our environment, Taylor uses only earth-friendly HFC refrigerants. The HFC refrigerant used in this machine is R404A. This refrigerant is generally considered nontoxic and nonflammable, with an ozone-depleting potential (ODP) of zero (0). However, any gas under pressure is potentially hazardous and must be handled with caution.

**NEVER** fill any refrigerant cylinder completely with liquid. Filling the cylinder to approximately 80% will allow for normal expansion.

### Compressor Warranty Disclaimer

1 The refrigeration compressor(s) on this machine are warranted for the term indicated on the warranty card accompanying this machine. However, due to the Montreal Protocol and the U.S. Clean Air Act Amendments of 1990, many new refrigerants are being tested and developed; thus seeking their way into the service industry. Some of these new refrigerants are being advertised as drop-in replacements for numerous applications. It should be noted that, in the event of ordinary service to this machine's refrigeration system, only the refrigerant specified on the affixed data label should be used. The unauthorized use of alternate refrigerants will void your compressor warranty. It will be the owners' responsibility to make this fact known to any technicians they employ.

It should be noted, that Taylor does not warrant the refrigerant used in its equipment. For example, if the refrigerant is lost during the course of ordinary service to this machine, Taylor has no obligation to either supply or provide its replacement either at billable or unbillable terms. Taylor does have the obligation to recommend a suitable replacement if the original refrigerant is banned, obsolete, or no longer available during the five-year warranty of the compressor.

Taylor will continue to monitor the industry and test new alternates as they are being developed. Should a new alternate prove, through our testing, that it would be accepted as a drop-in replacement, then the above disclaimer would become null and void. To find out the current status of an alternate refrigerant as it relates to your compressor, call the local Taylor distributor or the Taylor factory. Be prepared to provide the model/serial number of the machine in question.

# User Interface

C712/C713

1

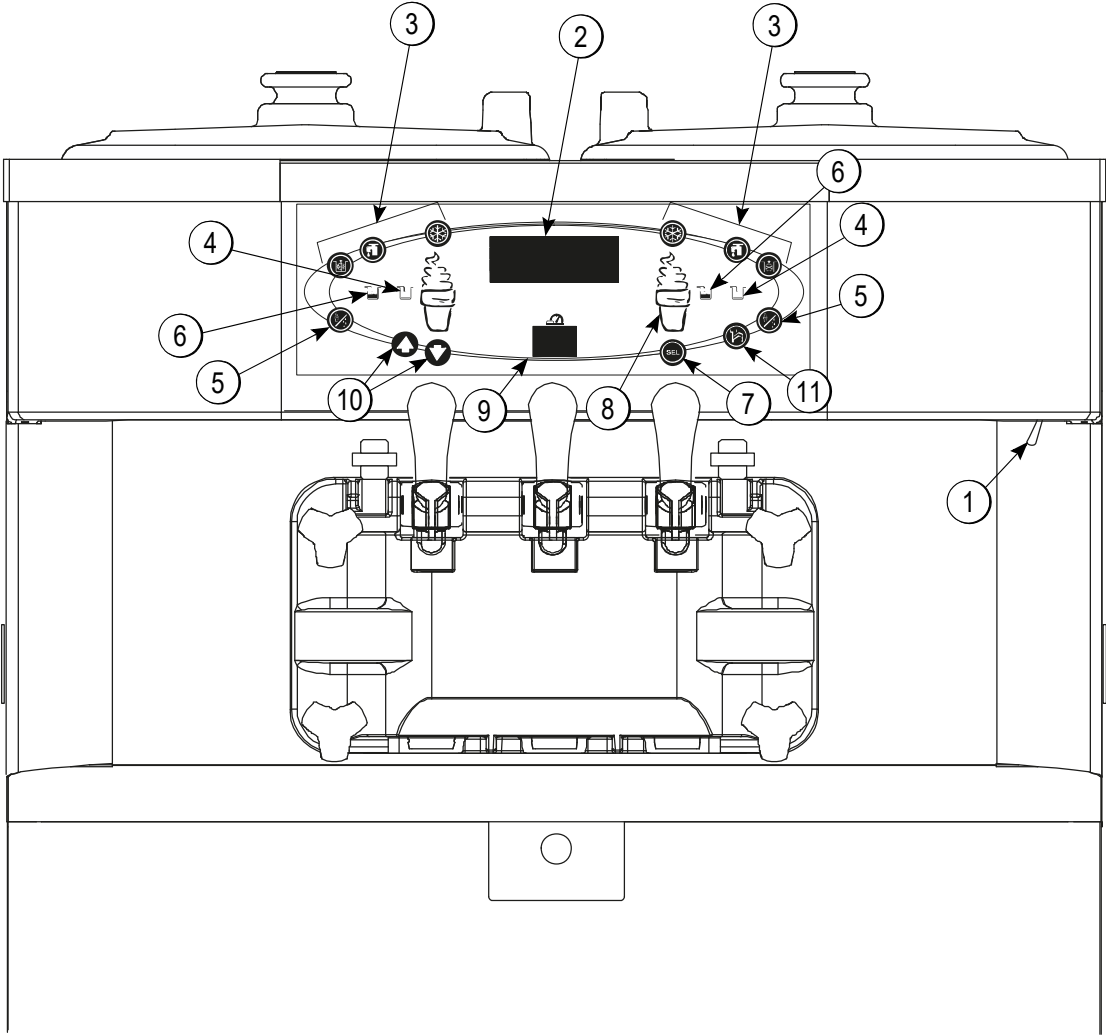

Figure 1-3

Item	Description
1	Power Switch
2	Liquid Crystal Display (LCD)
3	Buttons
4	Mix Out Indicator
5	Standby Button

Item	Description
6	Mix Low Indicator
7	Select Button
8	Service Menu Button
9	Brush Clean Counter
10	Arrow Buttons
11	Wash Button

**Note:** \*C713 does not have the Mix Pump Button.

## Symbol Definitions

To better communicate in the International arena, symbols have replaced words on many of our operator switches, function, and fault indicators. Your Taylor machine is designed with these international symbols.

The following chart identifies the symbol definitions.

1

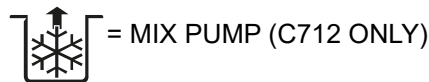
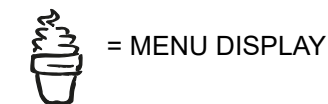
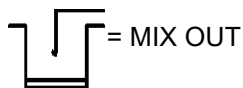
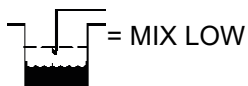
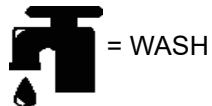
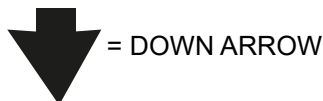

## Power Switch



When placed in the ON position, the power switch allows control panel operation.

## Liquid Crystal Display (LCD)

The liquid crystal display (LCD) is located on the front control panel. During normal operation, the display is blank. The display is used to show menu options and notifies the operator if a fault is detected. On international models, the display will indicate the temperature of the mix in the hopper.

## Indicator Lights

**MIX LOW** - When the Mix Low indicator  is illuminated, the mix hopper has a low supply of mix and should be refilled as soon as possible.

**MIX OUT** - When the Mix Out indicator  is illuminated, the mix hopper has been almost completely exhausted and has an insufficient supply of mix to operate the freezer. At this time, the Auto mode is locked out and the freezer will be placed in the Standby mode. To initiate the refrigeration system, add mix to the mix hopper and touch the Auto button . The freezer will automatically begin operation.

## Adjustable Draw Handle

This machine features an adjustable draw handle to provide the best portion control, giving a better, consistent quality to your product and controlling costs. The draw handle should be adjusted to provide a flow rate of 5 oz. to 7-1/2 oz. (142 g to 213 g) of product by weight per 10 seconds. To **increase** the flow rate, turn the screw **clockwise**, and **counterclockwise** to **decrease** the flow rate. (See Figure 1-4.)

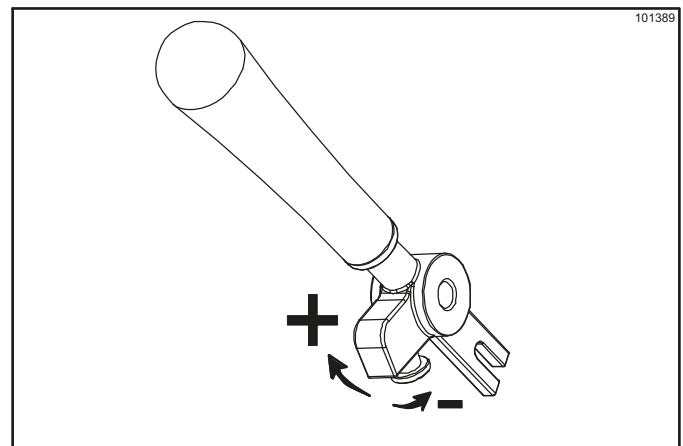



Figure 1-4

## Beater Motor Overload

The beater motor overloads are located in the rear panel. The beater motor overload protects the beater motor from an overload condition. Should an overload occur, the reset mechanism will trip. To properly reset the freezer, place the power switch in the OFF position. Press the reset button firmly. Turn the power switch to the ON position. Touch the Wash button and observe the freezer's performance.



**DANGER! DO NOT** use metal objects to press the RESET button. Failure to comply may result in severe personal injury or death.

If the beater motor is turning properly, touch the Wash button to cancel the cycle. Touch the Auto button  to resume normal operation. If the freezer shuts down again, contact your authorized service technician.

## Air/Mix Pump Reset Mechanism (C712 Only)

The RESET buttons for the pumps are located in the rear panel.

The reset protects the pump from overloading. Should an overload occur, the reset mechanism will trip. To reset the pump, press the RESET button firmly.



**DANGER! DO NOT** use metal objects to press the RESET button. Failure to comply may result in severe personal injury or death.

## Condenser Fan Motor

The condenser fan motor is driven by the software. The L1 to the fan is connected to the interface board at J6-6. The condenser fan is programmed to run any time the compressor is on and to stay running for 30 seconds after the compressor cycles off.



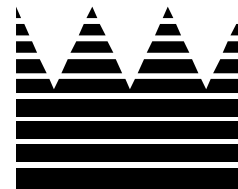

## **Section 2: Controls**

- **Universal Control Programming**
- **Power Interrupt**
- **Pump Operation**
- **Timers**
- **Beater Stir Cycles**
- **Setting Viscosity**
- **Jumper Pin Charts**
- **Control Overview - UVC4**
- **Universal Control Board - UVC4**
- **C712/C713 UVC4 Update Instructions**
- **Refrigeration Schematic**
- **Refrigeration System Components**

# Universal Control Programming

## Operating Screen Descriptions

The liquid crystal display (LCD) located in the center of the control panel is normally blank during the daily operation of the machine. The display is activated when the SEL button or the Manager's Menu is selected. The LCD screen will also alert the operator of specific faults detected by the control.

### 2 Power Up Memory (Initializing)

The seven-segment display should display 00 during the initializing sequence.

When the machine is powered, the control system will initialize to perform a system check. The screen will display Initializing. There will be three types of data the system will check: Language, System Data, and Config Data.

#### Language Initialization

The universal control (UVC) platform supports multiple languages by keeping specific strings in battery backed random-access memory (RAM). After power-up or a central processing unit (CPU) reset, the strings are tested to see if the language strings are present and not corrupted. If the strings are present and not corrupted, initialization continues. Otherwise, the operator is prompted to select a language. While language strings are being checked for integrity, the following screen is displayed.



Figure 2-1

**Note:** *If there is a language initialization fault, the machine will force a language selection prior to the initializing sequence. The standard menu LEDs should light, as if it were in a menu. If a language has been selected, the machine is powered down. The machine should not ask for a language unless there is another language initialization fault. English is the factory default setting.*

#### System Data

System data is protected separately from the rest of the data in memory. System data includes variables that

change frequently, such as the mode the machine is in, lockout status, serving counters, fault codes, and others. While System Data is being checked the following screen is displayed.



Figure 2-2

If the System Data is corrupted, the machine is set to OFF, the serving counters are set to zero, and the faults are cleared. A SYSTEM CRC ERR fault is set and displayed on the LCD. An acknowledgment is required (press SEL button).

#### Configuration Data

Configuration data is separate from the rest of the data in the memory. Configuration data is information entered through operator and service menus. While the Configuration Data is being checked, the following screen is displayed.



Figure 2-3

If the Configuration Data is corrupted, all user and service settings are set to defaults. A CONFIG CRC ERR fault is set and displayed on the LCD. The system will continue to operate in its previous mode, but according to default settings.

After the memory integrity has been tested, the Safety Timeout screen will be displayed.

Once the system has initialized, the number of hours since the last brush cleaning is indicated on the control panel. The SAFETY TIMEOUT screen will be displayed with the alarm on for 60 seconds, or until any control button is selected.





Figure 2-4

### Power Switch OFF

After the safety timeout has been completed and the power switch is OFF, the following screen is displayed.

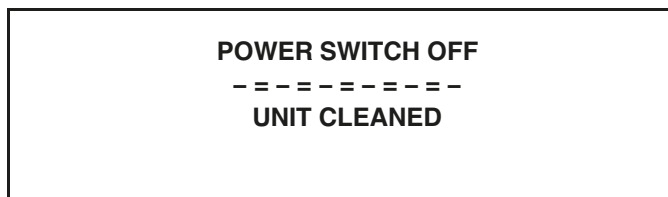

Figure 2-5



### Power Switch ON

When the power switch is placed in the ON position, the control panel buttons become operative. The LCD will be either blank or indicate that the machine has been cleaned.



Figure 2-6

### Manager's Menu

The Manager's Menu is used to enter the operator function displays. To access the Manager's Menu, press the center of the Service Menu button  on the control panel on the right side of the machine. The arrow buttons, the SEL button, and the Service Menu button  will be illuminated when the ACCESS CODE screen is displayed.

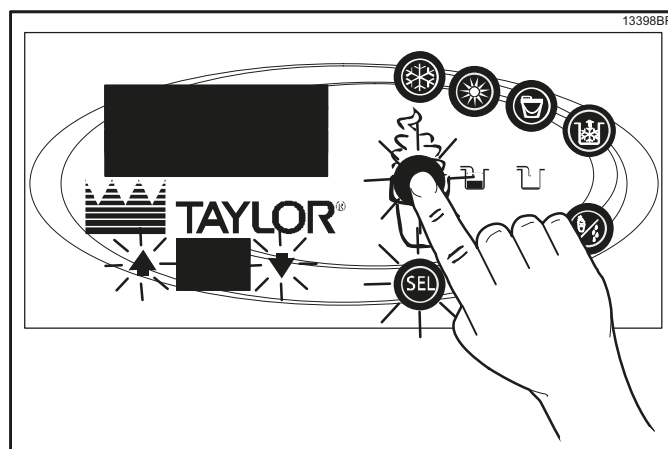

Figure 2-7

In the Menu program, the arrow buttons and the SEL button will function as menu buttons.

- **UP ARROW**—increases the value above the cursor and is used to scroll upward in text displays.
- **DOWN ARROW**—decreases the value above the cursor and is used to scroll downward in text displays.
- **SEL**—advances the cursor position to the right and is used to select menu options.

There is a 2 minute time-out in effect during the Manager's Menu. While in the Manager's Menu, if no activity occurs within a 2-minute period, the display will exit the Manager's Menu.

**Note:** The unit will continue operation in the mode it was in when the Manager's Menu was selected. However, the control buttons will not illuminate and are non-functional when the Manager's Menu is displayed.

### Entering Access Code

With the ACCESS CODE screen on the display, use the SEL button to set the first code number in the cursor position. When the correct number is selected, press the SEL button to move the cursor to the next number position.

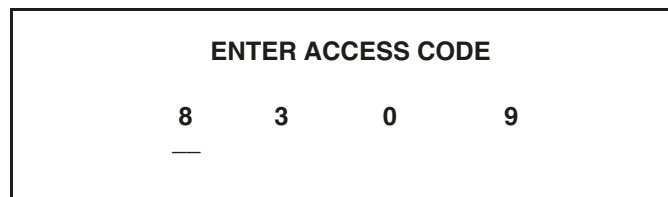

Figure 2-8

## CONTROLS

Continue to enter the proper access code numbers (8309) until all four numbers are displayed and then press the SEL button. The Manager's Menu list will display on the screen, provided the correct access code is entered.

If an incorrect number is entered for the access code, the display will exit the menu program when the SEL button is selected.

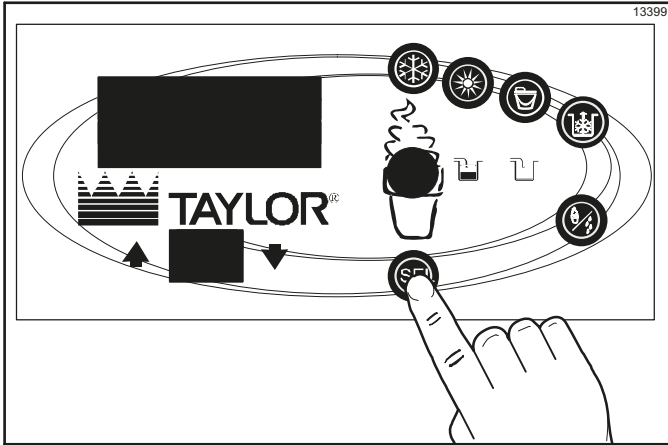



Figure 2-9

### Manager Menu Options

Press the Arrow buttons to move up or down through the Menu. Select a Menu option by pressing the SEL button. Exit the Menu program by selecting EXIT FROM MENU or pressing the Service Menu button .

The following menu options are listed in the Manager's Menu.

- EXIT FROM MENU
- SERVINGS COUNTER
- SET CLOCK
- AUTO START TIME
- STANDBY MODE
- MIX LEVEL AUDIBLE
- FAULT DESCRIPTION
- FAULT HISTORY
- LOCKOUT HISTORY
- SYSTEM INFORMATION
- CURRENT CONDITIONS
- NET SERVICE PIN

### Exit From Menu

Selecting EXIT FROM MENU will exit the Manager's Menu and return the control panel buttons to normal

operation.

### Servings Counter

The SERVINGS COUNTER screen is used to reset the servings counter to zero. The SERVINGS COUNTER automatically resets to zero when the machine is brush cleaned.

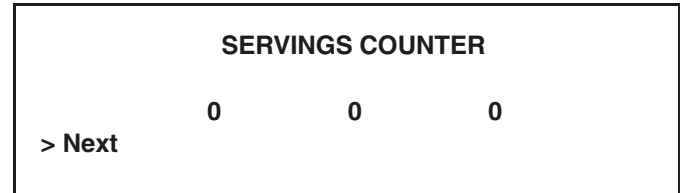

Figure 2-10

Reset the SERVINGS COUNTER by pressing the SEL button to advance to the next screen. Press the Up Arrow button to move the arrow (>) to Yes and then press the SEL button. The servings counter will reset to zero and exit back to the Manager's Menu.

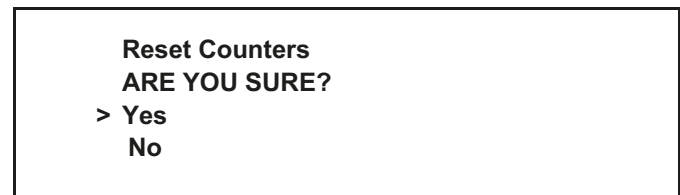

Figure 2-11

### Set Clock

The set clock option allows the manager or service technician to adjust the real-time clock if the machine is in the brush cleaned state. The following message will display if the set clock option is selected when the machine is **not** in a brush clean state.



Figure 2-12

If the machine is in the brush cleaned state, pressing the SEL key would display the following screen.

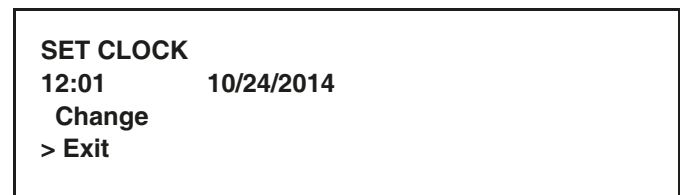

Figure 2-13

To make any changes, press the Up Arrow to move to

Change and press the SEL button. Pressing the SEL button will scroll the cursor to the right one digit for each button press. Pressing the Up or Down Arrow buttons increases or decreases the selected digits.

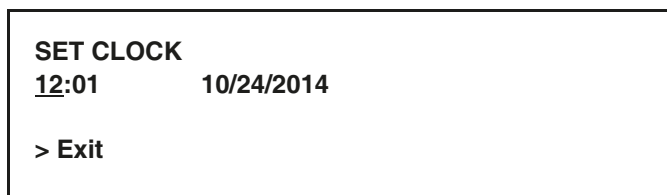

Figure 2-14

After all changes have been made and the year has been set, pressing the SEL button will display the first DAYLIGHT SAVING TIME (DST) screen.



Figure 2-15

Pressing the Up or Down Arrow buttons will move the arrow to Enable or Disable. Pressing the SEL button next to Disable will disable Daylight Saving Time and return to the Manager Menu. Pressing the SEL button next to Enable selects that option and displays the Month and Sunday screen.

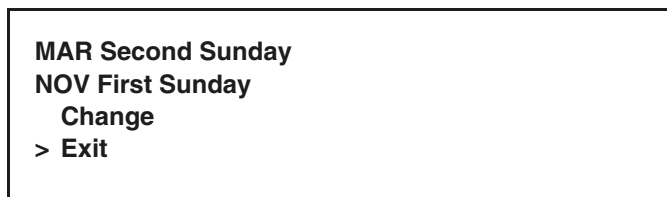

Figure 2-16

If the correct Sunday for the time change is not displayed, then Change should be selected. Pressing the SEL button with the arrow next to Change displays the DST Start Month screen. Press the Up or Down Arrow button to move the arrow to the appropriate month for the start of DST.

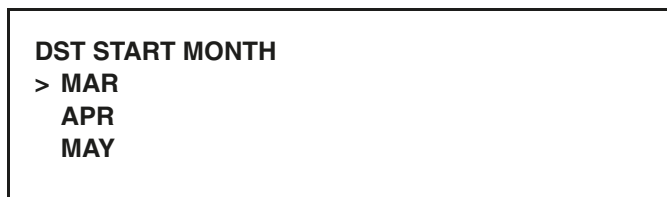

Figure 2-17

Pressing the SEL button with the arrow next to the appropriate month selects the START MONTH and then

displays the DST START WEEK screen. Pressing the Up or Down button will move the arrow to the appropriate week for the start of DST.

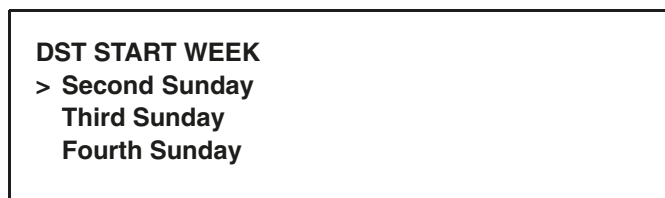

Figure 2-18

Pressing the SEL button next to the appropriate week will display the DST END MONTH screen. Press the Up or Down button to move the arrow to the appropriate month for the end of DST.

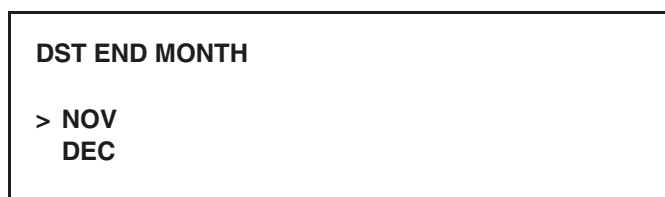

Figure 2-19

Pressing the SEL button next to the appropriate month will display the DST END WEEK screen. Press the UP or DOWN button to move the arrow to the appropriate week for the end of DST.

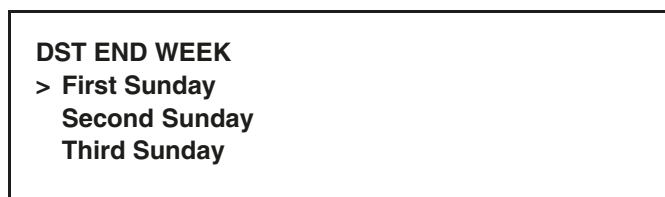

Figure 2-20

Pressing the SEL button with the arrow next to the appropriate week will select that setting and return to the Menu screen.

**Auto Start Time**

The AUTO START TIME option allows the Manager to set the time of day at which the unit automatically enters the Auto mode from the Standby mode. The unit must be in the Standby mode without a freezer lock condition in order to AUTO START at the programmable time. The AUTO START TIME can also be disabled and require starting the Auto mode manually.



Figure 2-21

Enable the AUTO START TIME by selecting the Up Arrow button to move the arrow to Enable. Press the SEL button to advance to the next screen.

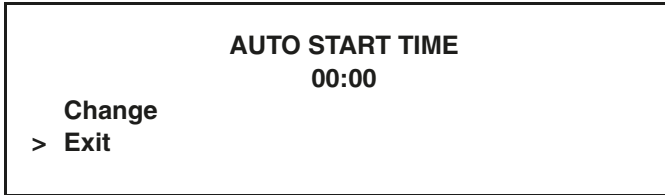

Figure 2-22

Program the AUTO START TIME by selecting the Up Arrow button to move the arrow to Change. Press the SEL button to advance to the next screen.

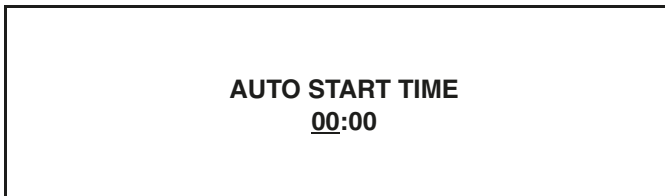

Figure 2-23

Use the arrow buttons to program the AUTO START TIME by increasing or decreasing the hour setting above the cursor. Touch the SEL button to advance the cursor and program the minutes setting. Touch the SEL button to return to the previous screen with the new time setting displayed. Touch the SEL button to exit the screen and return to the Manager's Menu.

**Standby Mode**

The STANDBY MODE option is used to manually place the machine in the Standby mode during long, no-draw periods. Press the Up Arrow button to place the arrow next to the appropriate side. Press the SEL button to place that side of the machine into Standby and return to the main menu screen.



Figure 2-24

**Mix Level Audible**

The MIX LEVEL AUDIBLE option, when enabled, will alert the operator with an audible tone when there is a mix-low or mix-out condition. The following screen is displayed upon selecting this option.



Figure 2-25

Disable the audible tone feature by pressing the Down Arrow button to move the arrow to Disable. Touch the SEL button to save the new setting and return to the Manager's Menu. The control panel icons for Mix Low and Mix Out will illuminate as the mix level drops in the hopper, but the audible tone will be disabled.

**Fault Description**

The LCD is located on the front control panel. During normal operation, the display is blank. The display is used to show menu options and notifies the operator if a fault is detected. On international models, the display will indicate the temperature of the mix in the hopper. If a fault does occur, it will appear on the display.

**NO FAULT FOUND**—There was no fault found in the freezer. Nothing will appear on the screen after this variable message appears.

**BEATER OVERLOAD**—Place the power switch in the OFF position. Press the beater reset button firmly. Place the power switch in the ON position and restart in AUTO.

**HPCO COMPRESSOR**—Place the power switch in the OFF position. Wait 5 minutes for the unit to cool. Place the power switch in the ON position and restart in AUTO.

**PRODUCT DOOR OFF**—The door must be installed on the unit.

**\*HOPPER THERMISTOR FAIL**—Place the power switch in the OFF position. Replace the hopper thermistor probe.

**\*BARREL THERMISTOR FAIL**—Place the power switch in the OFF position. Replace the barrel thermistor probe.

**Note:** Three codes have been set up to assist in diagnosing bad thermistor probes. If a probe has shorted (resistance less than 1 ohm), SHRT will be displayed on the screen for its respective unit location. If the probe is open (resistance above 1 megohm), OPEN will be

displayed. If the actual probe environment exceeds 200 °F (93°C), the respective screen display location will read OVER indicating the temperature is **out of range**.

**Fault History**

The FAULT HISTORY will display up to 100 faults that have occurred. Page numbers are displayed in the upper right corner. Page one contains the most recent fault. Pressing the Up Arrow button cycles through the FAULT HISTORY pages from most recent to oldest. Pressing the Down Arrow button cycles from the oldest to the most recent. The date and time of the event are displayed on the second line. The third line displays the reason for the fault.

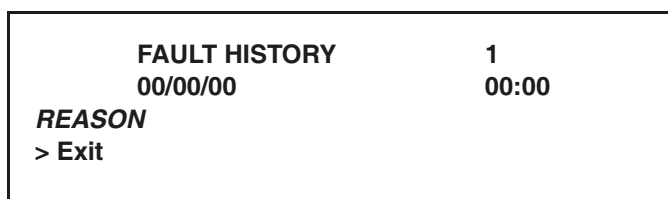

Figure 2-26

**Faults Occurring While in AUTO or STANDBY Mode**

**(L/R) HPR>41F (5C) AFTER 4 HR**—The mix temperature in the hopper was above 41°F (5°C) for more than 4 hours.

**(L/R) BRL>41F (5C) AFTER 4 HR**—The mix temperature in the freezing cylinder was above 41°F (5°C) for more than 4 hours.

**(L/R) HPR>41F (5C) AFTER PF**—The mix temperature in the hopper was above 41°F (5°C) for more than 4 hours following a power failure.

**(L/R) HPR>45F (7C) AFTER 1 HR**—The mix temperature in the left or right hopper was above 45°F (7°C) for more than 1 hour.

**(L/R) BRL>45F (7C) AFTER 1 HR**—The mix temperature in the left or right barrel was above 45°F (7°C) for more than 1 hour.

**(L/R) BRL>41F (5C) AFTER PF**—The mix temperature in the freezing cylinder was above 41°F (5°C) for more than 4 hours following a power failure.

**(L/R) HPR>59F (15C)**—The mix temperature in the hopper exceeded 59°F (15°C).

**(L/R) BRL>59F (15C)**—The mix temperature in the hopper exceeded 59°F (15°C).

**(L/R) COMP ON TOO LONG**—The compressor run time exceeded the 11 minute timer.

**Note:** Refer to your local health codes regarding temperature recommendations for procedures to follow if these fault screens appear.

**Lockout History**

The LOCKOUT HISTORY screen displays a history of the last 100 soft locks, hard locks, brush clean dates, or aborted heat cycles. Page numbers are indicated in the upper right corner. Page 1 always contains the most recent failure.

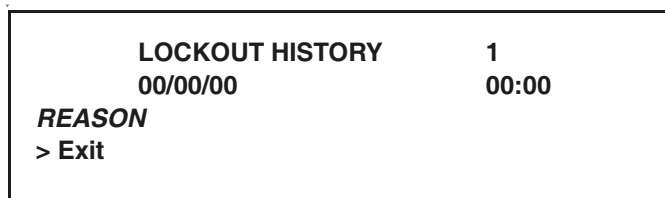

Figure 2-27

The second line of the screen displays the date and time a failure occurs. The third line indicates the reason for a failure, or will indicate if a successful brush cleaning has occurred. Some failures occur with multiple reasons. When this occurs, a record will be generated for each reason.

Use the arrow buttons to move forward or backward to view each screen.

**System Information**

The SYSTEM INFORMATION is displayed on three separate screens. The first screen contains the control and software version installed in the machine.



Figure 2-28

Touch the SEL button to advance to the next system information screen containing the software language version.

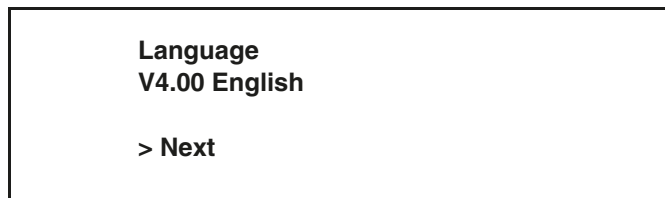

Figure 2-29

Touch the SEL button to advance to the third system information screen containing the model bill of material

and machine serial number.

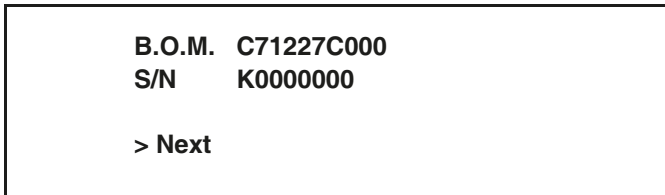

Figure 2-30

Pressing the SEL button again will return to the Menu screen.

## 2

### Current Conditions

This screen provides the viscosity readings for the product when the unit is running, and the hopper and the freezing cylinder temperatures for the unit.

VISC	0.0	0.0
HOPPER	41.0	41.0
BARREL	41.0	41.0

Figure 2-31

Press the SEL or Menu button to return to the Menu screen.

### Net Service Pin

The NET SERVICE PIN screen allows the manager or service technician to initialize a network connection for networking kitchens.

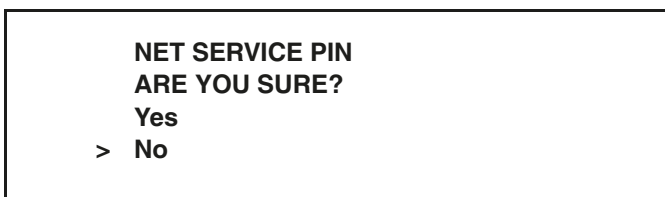

Figure 2-32

Pressing the Up or Down Arrow button will move the arrow to Yes or No. Pressing the SEL button with the arrow next to No will return to the Menu screen. Pressing the SEL button with the arrow next to Yes will connect to the network if a gateway card is connected. If Yes is selected, the unit will appear to hang until the memory is cleared and the defaults are loaded. The display may show the message COMMUNICATIONS FAILURE during this time.

## Service Menu

The Service Menu option allows authorized, service technicians to access and modify critical operating parameters for the machine. The access code for the Service Menu is: **5 2 3 1**.

### Service Menu Options

The Service Menu screen includes the following options which are also displayed in the Manager's Menu. (See page 2-3.)

- EXIT FROM MENU
- SERVINGS COUNTER
- SET CLOCK
- AUTO START TIME
- STANDBY MODE
- MIX LEVEL AUDIBLE
- FAULT DESCRIPTION
- FAULT HISTORY
- LOCKOUT HISTORY
- SYSTEM INFORMATION
- CURRENT CONDITIONS
- NET SERVICE PIN

The Service Menu screen also includes the following options which can only be accessed through the Service Menu:

- TEMPERATURE SCALE
- STANDBY TEMP
- HOPPER TEMP
- VISCOSITY SETTING
- COMPRESSOR CYCLE TIME
- COMPRESSOR ON DELAY
- BEATER OFF DELAY
- MIX PUMP OFF DELAY
- EDIT UNIT ID
- SELECT LANGUAGE
- MANUAL CONTROL
- SOFTWARE UPDATE
- RESET TO DEFAULTS

### Temperature Scale

This option allows the service technician to choose the scale in which the machine will display all temperatures.



Figure 2-33

Use the Up and Down Arrow buttons to move to the appropriate option. Press the SEL button to confirm the selection and return to the Service Menu screen.

**Standby Temp**

This option allows the technician to adjust the freezing cylinder temperature at which the compressor will turn on in Standby mode. Standby temperatures must be set to maintain hopper and freezing cylinder temperatures below 40°F (4.4°C). The left/right choice screen is displayed upon selecting this option.

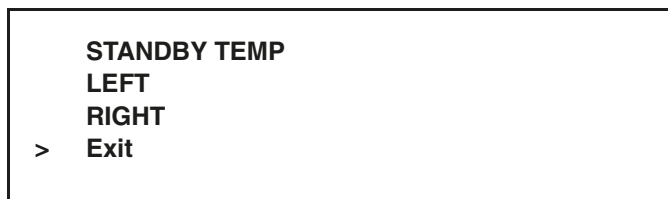

Figure 2-34

Pressing the Up and Down Arrow buttons move the arrow to LEFT, RIGHT, or Exit. Pressing the SEL button with the arrow next to LEFT or RIGHT will display the second screen, which allows the setting of the standby temperature for that side.

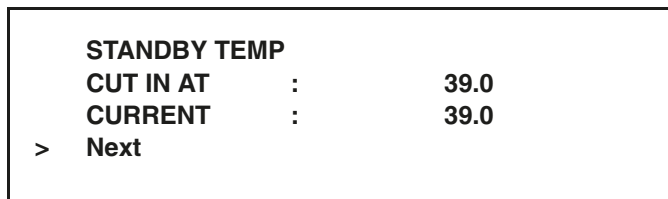

Figure 2-35

Pressing the Up or Down Arrow button increases and decreases the temperature by 1/2° respectively.

Pressing the SEL button accepts the setting and returns to the Menu screen. Pressing the Menu button with either screen showing ignores any changes and returns to the Menu screen.

**Hopper Temp**

This option allows the technician to adjust the hopper temperature in Auto and Standby. The first screen prompts the technician to choose a side (left or right). After that selection is made, the following screen displays.

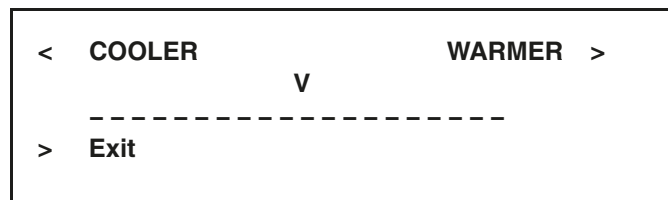

Figure 2-36

The V indicates the current setting. Pressing the Up Arrow button moves the V one position to the right (warmer). Pressing the Down Arrow button moves the V one position to the left (cooler). Pressing the SEL button stores the value of the setting and returns to the Service Menu screen. The temperature differential is 2°F (1°C) for the hopper temperature.

**Viscosity Setting**

This option allows the service technician to adjust the viscosity at which the compressor turns off in Auto mode. The first screen prompts the service technician to choose a side (left or right). After that selection is made, the following screen displays.

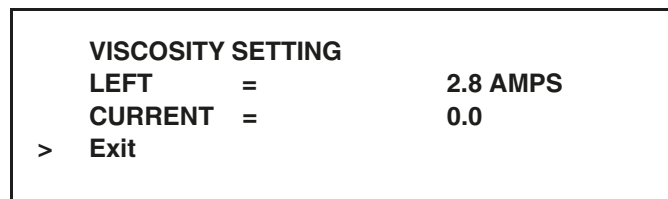

Figure 2-37

Pressing the Up Arrow button moves the arrow to Change. Pressing the Down Arrow button moves the arrow to Exit. Pressing the SEL button with the arrow next to Exit has no effect and returns to the Service Menu screen.

Pressing the Up Arrow button increases the viscosity setting by 0.1 amp. Pressing the Down arrow button decreases the viscosity setting by 0.1 amp. Pressing the SEL button accepts the viscosity setting and returns to the L/R choice screen. Pressing the SEL button again returns to the Service Menu screen.

**Compressor Cycle Time**

This option allows the technician to set the Compressor Cycle Time. The first screen prompts the technician to choose a side (left or right). After that selection is made, the following screen displays:



COMP CYCLE TIME  
L CYCLE TIME : 10 MIN

Figure 2-38

Pressing the Up or Down Arrow button increases or decreases the cycle time by 1 minute respectively. Pressing the SEL button accepts the setting and returns to the L/R choice screen. Pressing the SEL button again returns to the Service Menu screen.

2

### Comp On Delay

This option allows the technician to adjust the main compressor on delay. After selecting the appropriate side of the machine, the following screen is displayed:

COMP ON DELAY  
LEFT : 2 SECONDS

Figure 2-39

Pressing the Up or Down Arrow button increases or decreases the time delay by one second respectively. Pressing the SEL button accepts the setting and returns to the L/R choice screen. Pressing the SEL button again returns to the Service Menu screen.

**Note:** The minimum setting for Comp On Delay is 2 seconds.

### Beater Off Delay

This option allows the technician to set the amount of time the beater motor continues to run after the compressor has cycled off. After selecting the appropriate side of the machine, the following screen is displayed.

BEATER OFF DELAY  
LEFT : 0 SECONDS

Figure 2-40

Pressing the Up or Down Arrow button increases or decreases the time delay by one second respectively. Pressing the SEL button accepts the setting and returns to the L/R choice screen. Pressing the SEL button again returns to the Service Menu screen.

### Mix Pump Off Delay (C712 Only)

This option allows the technician to set the amount of time that the mix pump runs after the draw valve has closed (switch opened). After selecting the appropriate side of the machine, the following screen is displayed.

MIX PUMP OFF DELAY  
LEFT : 10 SEC

Figure 2-41

Pressing the Up or Down Arrow button increases or decreases the time delay by one second respectively. Pressing the SEL button accepts the setting and returns to the L/R choice screen. Pressing the SEL button again returns to the Service Menu screen.

### Edit Unit ID

This option allows the technician to enter the factory Bill of Materials (BOM) code used to assemble the freezer, the freezer serial number, and the store ID number. The FREEZER BOM screen is displayed first.

ENTER FREEZER BOM  
C 7 0 0 0 0 0 0 0  
-

Figure 2-42

Pressing the SEL button scrolls the cursor to the right, one place for each button press. Pressing the Up or Down arrow button increases or decreases respectively, with rollover, the selected digits. Once the correct freezer BOM has been entered, pressing the SEL button displays the serial number screen.

ENTER FREEZER SN  
K 0 0 0 0 0 0  
-

Figure 2-43

Repeat the operation as described previously. Once the correct freezer serial number has been entered, pressing the SEL button displays the store ID screen.



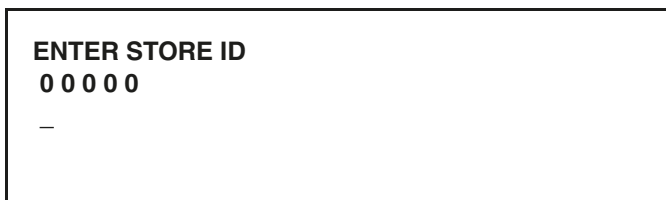

Figure 2-44

Repeat the operation as described previously. Once the correct store ID has been entered, pressing the SEL button returns to the Service Menu screen.

**Select Language**

This option allows the technician to select one of eleven languages available. The following screen will be displayed upon selecting this option:

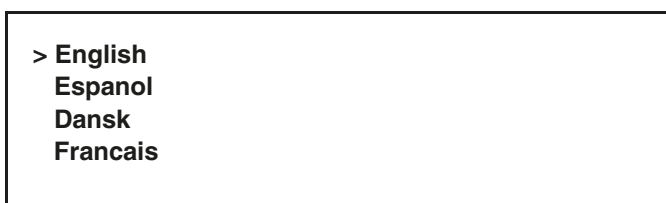

Figure 2-45

Pressing the Up or Down Arrow button moves the arrow to the selection. Pressing the SEL button with the arrow next to one of the choices selects that choice and returns to the Service Menu screen. If no language is selected, the factory default is English.

**Note:** A graphics display is required for the Russian language. If the Russian language is selected on a machine that does not have a graphics display, the following error message will display:

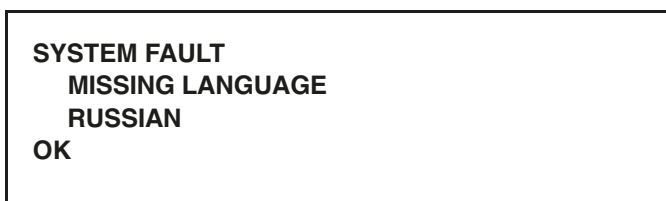

Figure 2-46

The available languages are English, Espanol (Spanish), Dansk (Danish) Francais (French), Svenska (Swedish), Deutsch (Dutch), Nederlands (Netherlands), Italiano (Italian), Portuguese, Polski (Polish), and Russian.

**Manual Control**

This option allows the technician to start and stop button components to test their performance. When selected manually, power will be supplied to each component until the technician selects OFF or exits the screen. The technician must manually select OFF or exit the menu.

- > EXIT
- L BEATER MOTOR
- L COMPRESSOR
- L MIX PUMP (C712 Only)
- L AGITATOR
- R BEATER MOTOR
- R COMPRESSOR
- R MIX PUMP (C712 Only)
- R AGITATOR
- HOPPER COOLING
- FAN

The freezer must be in the OFF mode to use this feature.

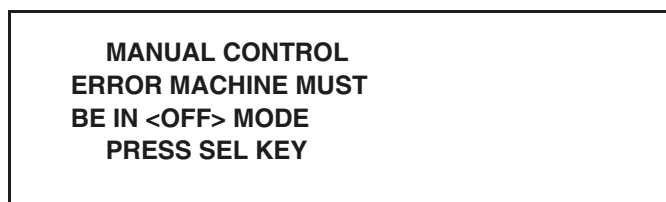

Figure 2-47

Press the SEL button to enter the manual control option.



Figure 2-48

Pressing the SEL button with the arrow on START will send voltage to the component selected.



Figure 2-49

Pressing the SEL button with the arrow on OFF will turn the component off. Moving the arrow to EXIT will turn the component off and exit this menu option.

## Software Update

This option allows the machine's firmware to be updated. Selecting this option will display a screen asking ARE YOU SURE?

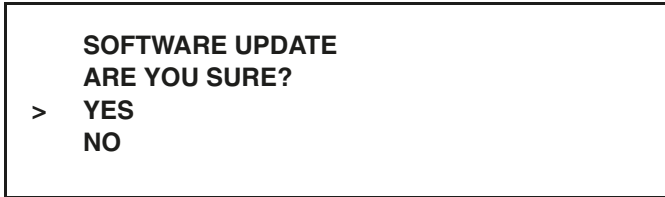

Figure 2-50

**2** Pressing the Up Arrow button moves the arrow to Yes. Pressing the SEL button will start the update process.

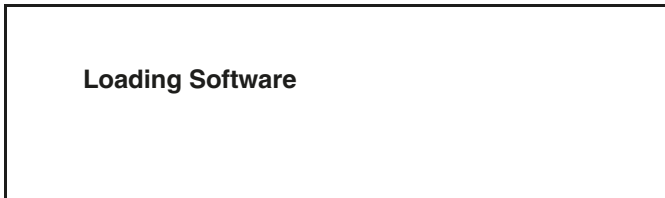

Figure 2-51

## Reset to Default

The Reset to Default option will allow the service technician to clear all RAM memory. This screen was added because it will not be possible to remove the RAM chip on future iterations of the UVC3 control. The machine must be in a **Unit Cleaned** status in order to restore the default settings. Selecting this option in the menu will display a screen asking ARE YOU SURE? (See Figure 2-52.)

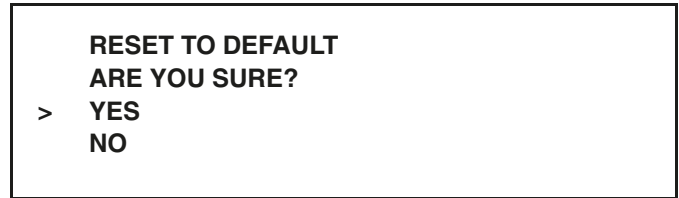

Figure 2-52

Moving the cursor to YES and selecting the Calibration button will restore all factory default values.

## Power Interrupt

All operating modes and setpoints are stored in the battery backed memory. Having been in Auto or Standby, recovery from a power failure will return the machine to its previous mode of operation after a Memory Initialization function has occurred. If a power failure has occurred, the Safety Time Out screen will display a Power Failure message on the first line and the audio alarm will be ON. This message must be cleared.

If the freezing cylinder or hopper temperature rises above 45°F (7°C) more than 1 hour or rise above 41°F (5°C) for 4 hours, the machine will soft lock when power is restored. If the temperature rises above 59°F (15°C) the machine will lock immediately.

### Daily Brush Clean

Every day the machine must be brush cleaned and the following criteria must be met.

1. The freezing cylinder and hopper temperatures must be above 60°F (16°C).
2. The MIX-OUT and MIX-LOW probes must not be satisfied.
3. The door must be removed.

**Note:** The power switch must be OFF to view the 5 minute countdown timer.

**Note:** The criteria in Steps 1–3 must be met simultaneously for 5 minutes. These criteria will be met when the machine is properly brush cleaned according to the Taylor Operator's Manual.

Completion of a successful brush clean resets the Brush Clean Cycle timer and removes the locked condition.

A screen showing the status of the elements required for a brush clean is displayed when the power switch is in the OFF position and the unit is not in a brush clean state.

**Line 1:** Indicates the power switch is OFF.

**Line 2:** Shows the time (in minutes and seconds) remaining for the system to enter a Brush Clean state.

**Line 3:** Shows the hopper temperature.

**Line 4:** Shows the barrel temperature.

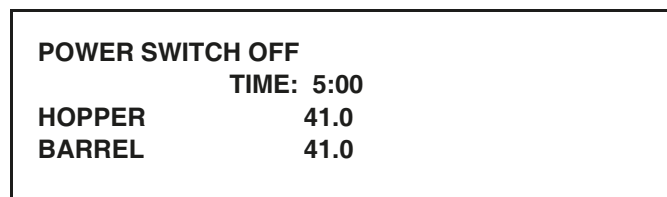

Figure 2-53

If any of the requirements for a brush clean have not been met, the time displayed will remain at 5:00 minutes. When all the requirements for a brush cleaning are met, and the 5 minutes expire, the screen will change to the second screen, which is the standard power switch OFF screen.

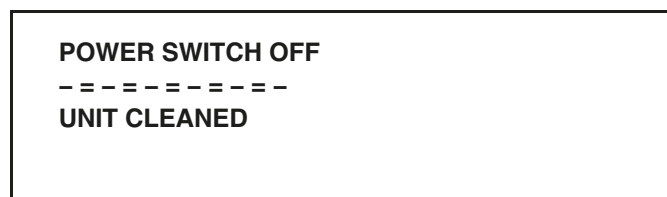

Figure 2-54

When the power switch is placed in the ON position, the third line of the screen will display **Unit Cleaned**.

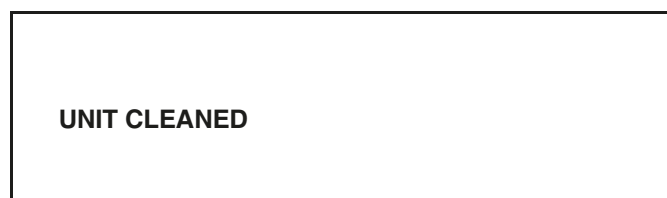

Figure 2-55

# Pump Operation

The pump operates under the following conditions:

## Pump Button

When the Pump button is touched, the pump is active by itself or with the Wash mode of operation.

## Mix Pump

**2** The mix pump will be active for 30 seconds whenever the

Auto mode is entered. If a mix out condition forces the machine into the Standby mode of operation, the mix pump will not be active.

## Mix Pump Draw Timer

During the Auto mode, the mix pump will operate for 5 to 30 seconds after every draw of product. The factory setting is 10 seconds.

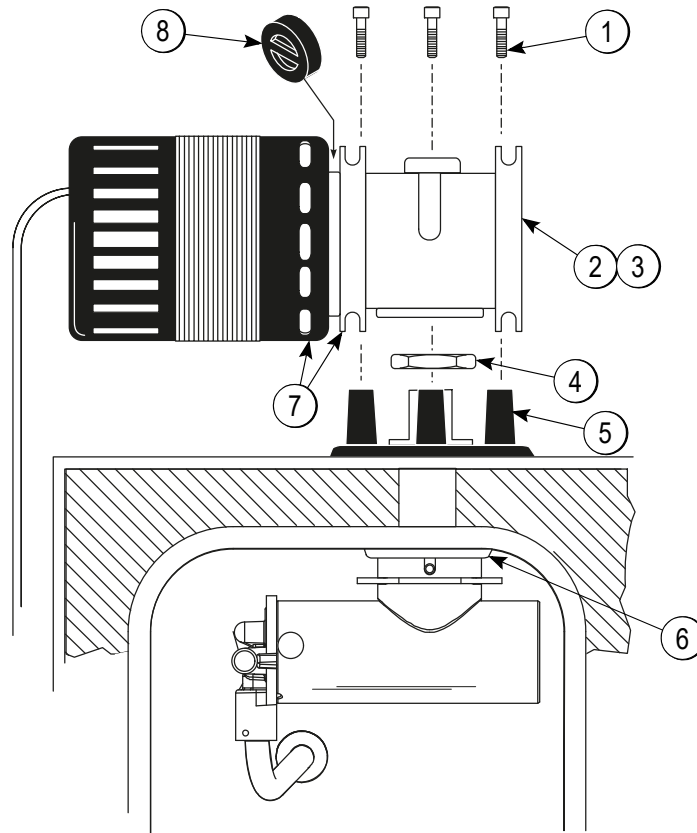

Figure 2-56

Item	Description	Part No.
1	Screw-1/4-20x-3/4 Socket	020128-2
2	Seal-Motor Reducer Input Shaft	048836
3	Seal-Motor Reducer- Output Shft	048837
4	Nut-Pump Sleeve	036933

Item	Description	Part No.
5	Mount-Motor	036934
6	Sleeve A.-Mix Pump	X44761
7	Motor-Reducer 32 RPM	036955-34
8	Coupling-Motor-Flexible	047936

## Timers

### Two Minute Stir Cycle

If the machine is in the Standby mode, the beater motor will turn on for 6 seconds every 2 minutes when the Standby Temp setpoint 26.5°F (-4°C) is satisfied.

### Mix Pump Timer

The mix pump will run for 30 seconds anytime the machine is placed in the Auto mode, but not from Standby.

### Mix Draw Timer

During the Auto mode, the mix pump will run for 5 to 30 sec. every time product is drawn from the machine. The factory setting is 10 sec.

### Safety Timeout

Once power is applied to the machine, a 60 second timer places the machine in an Idle state. The tone is turned on in 0.5 second intervals, and a Safety Timeout message appears on the LCD. This timer can be aborted by touching any button.

### Brush Clean Timer

This timer times out 5 minutes when all conditions for a successful brush cleaning are met.

# Beater Stir Cycles

### Standby

When the machine is in the Standby mode, the stir cycle will be activated. The beater stir cycle timer counts down 2 minutes (in seconds) and then activates the beater motor for 6 seconds. After the stir cycle, the process will repeat itself; the timer will count down 2 minutes, and the beater will run for 6 seconds.

### Hopper Temperature

The hopper temperature setpoint range is 29.5°F to 39°F (-1.4°C to 3.9°C). In the Auto or Standby mode, the compressor starts when the hopper temperature is above the setpoint and stops when the hopper temperature reaches the setpoint -2°.

# Setting Viscosity

## Viscosity

Viscosity is the term used when referring to product appearance, temperature, thickness and firmness.

Soft serve viscosity is measured by monitoring the amperage load of the beater motor. The amperage load of the beater motor is low when the product in the freezing cylinder is liquid. As the product freezes (thickens), the amperage load increases. When the amperage load reaches the setpoint, the refrigeration cycle discontinues.

The factory setting (setpoint) for soft serve viscosity is 2.8 amps. The amperage measurement is determined by monitoring the L1 leg of power being delivered to the beater motor. To adjust the serving viscosity, it may be necessary to raise or lower the amperage setpoint. Adjust in increases of 0.1 amps.

The serving temperature of soft serve product may vary throughout the day. The serving temperature may range from 16°F to 19°F (-8.8°C to -7.2°C).

<b>VISCOSITY SETTING</b>			
<b>VISC</b>	<b>=</b>	<b>2.8</b>	<b>AMPS</b>
<b>CURRENT</b>	<b>=</b>	<b>0.0</b>	

Figure 2-57

# Jumper Pin Charts

## Jumper Chart - UVC3

2

Feature	C712/C713 Left Interface X59485-SER	C712/C713 Left Interface X59485-SER
Force Brush Clean Status	W2	
Syrup Heater Enable	W3	
Open All Left Solenoids	W4	
Open All Right Solenoids		W4
Clock/Calendar Override	W5	
Force Glycol Pump On		
59F Fault Detection Enable		W2**
Standby Stir Cycle Disable		W5
Reduced Mix Low Sensitivity	W6	W6
Reduced Mix Out Sensitivity	W7	W7
7C/45F 90 Min. Cool Phase		
Unused	W1	W1
Unused		W3
Disable Control Panel (Self Serve)	J10 - 7 & 8	

\*\* Jumper initially installed at factory.

Table 2-1

UVC4 Control Feature	Jumper
>41F for 4 hours & >45 for 1 hr	JP1 - 1 & 2**
Reserved (do not install)	JP1 - 3 & 4
Domestic/International ( <b>Note 3</b> )	JP2 - 1 & 2 **
Reserved (do not install)	JP3 - 3 & 4
Audible enable (do not install)	JP3 - 1 & 2
Unused	JP3 - 3 & 4

\*\* Jumper initially installed at factory.

Table 2-2

Personality Board	
0 - 6 Beater Motor Amperage (do not use)	A
0 - 12 Beater Motor Amperage	B**

\*\* Jumper initially installed at factory.

Table 2-3

**Notes:**

1. Left and right are determined while facing the front of machine.
2. Specified feature is established when the jumper is installed.
3. International mode (jumper removed) enables direct use of Heat and Standby buttons and hopper temperature display.



Jumper Pin Chart - UVC4

Feature	C712/C713 Left Interface X59485-SER	C712/C713 Right Interface X59485-SER
Force Brush Clean Status	W2	
Syrup Heater Enable	W3	
Open All Left Solenoids	W4	
Open All Right Solenoids		W4
Clock/Calendar Override	W5	
Force Glycol Pump On		
59F Fault Detection Enable		W2**
Standby Stir Cycle Disable		W5
Reduced Mix Low Sensitivity	W6	W6
Reduced Mix Out Sensitivity	W7	W7
7C/45F 90 Min. Cool Phase		
Unused	W1	W1
Unused		
Disable Control Panel (Self Serve)	J10 - 7 & 8	

2

\*\* Jumper initially installed at factory.

Table 2-4

UVC4 Control Feature	Jumper
>41F for 4 hours & >45 for 1 hr	JP1 - 1 & 2**
Reserved (do not install)	JP1 - 3 & 4
Domestic/International ( <b>Note 3</b> )	JP2 - 1 & 2 **
Reserved (do not install)	JP3 - 1 & 2
Reserved (do not install)	JP4 - 1 & 2
Proximity Sensor ( <b>Note 4</b> )	JP5 - 1 & 2**
Reserved (do not install)	JP6 - 1 & 2
Reserved (do not install)	JP7 - 1 & 2
Reserved (do not install)	RTCK - 1 & 2
Reserved (do not install)	DBGEN - 1 & 2

\*\* Jumper initially installed at factory.

Table 2-5

Personality Board	
0–6 Beater Motor Amperage (do not use)	A
0–12 Beater Motor Amperage	B**

\*\* Jumper initially installed at factory.

Table 2-6

**Notes:**

1. Left and right are determined while facing the front of machine.
2. Specified feature is established when the jumper is installed.
3. International mode (jumper removed) enables direct use of Heat and Standby buttons and hopper temperature display. **Note:** C712/C713 Standby buttons are always enabled. C712/C713 do not have Heat buttons.
4. Jumper should be installed on shake machines to enable proximity sensor. It is not active on soft serve machines; jumper can remain installed.

# Control Overview - UVC4

Dec Plate - Includes interface board  
C712 - 062121



Dec Plate - Includes interface board  
C713 - 062122



063925-SER  
Control Panel  
Interface Board

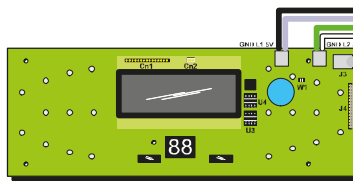

056864

CABLE 069023

2

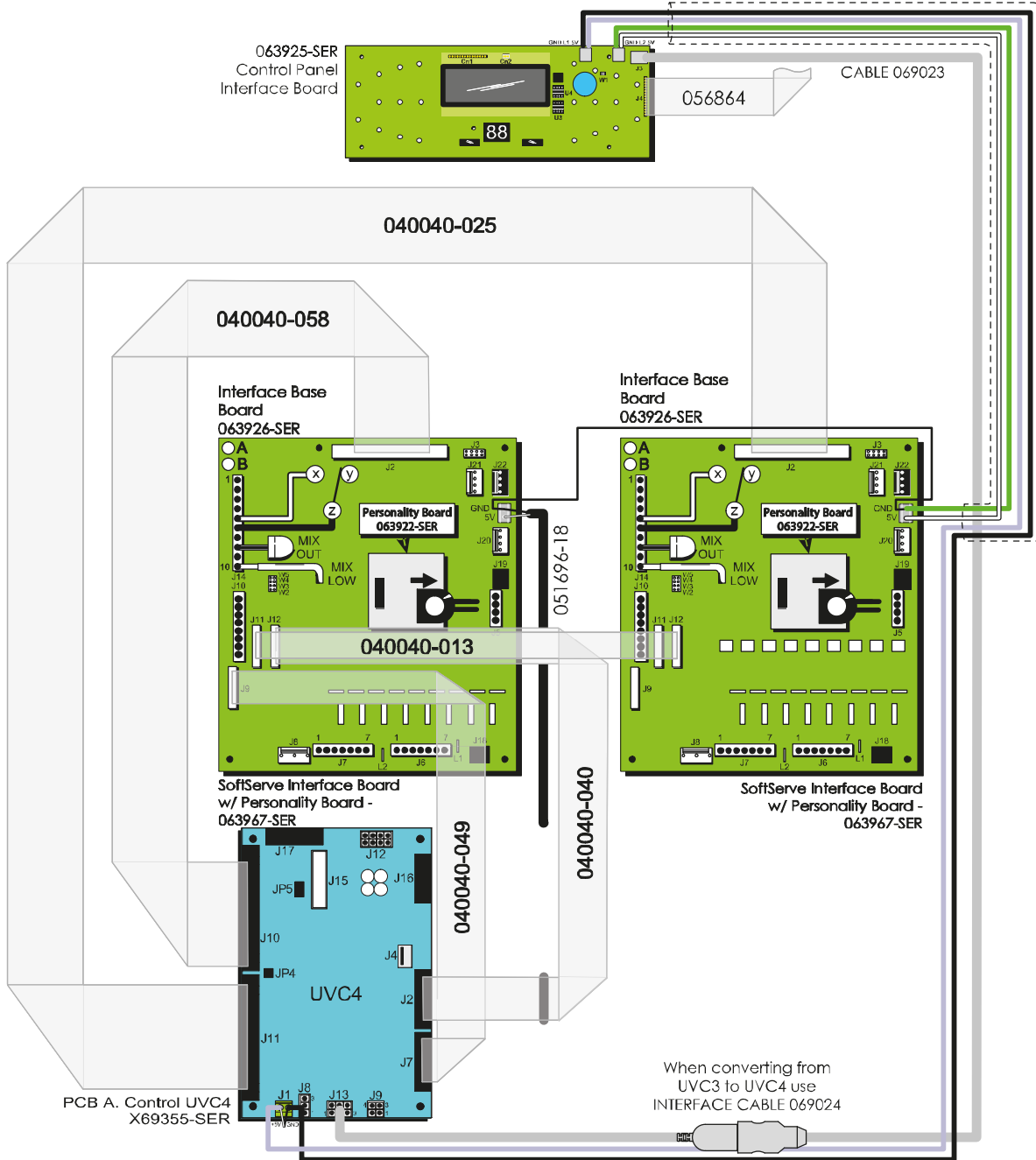

Figure 2-58

# Universal Control Board - UVC4

## Universal Control Board Connections - UVC4 (X69355-SER)

Beginning in January 2011, Taylor transitioned from the UVC3 to the UVC4.

**Note:** UVC4 can only be used to replaced UVC3 boards. UVC4 is not compatible with UVC1 or UVC2.

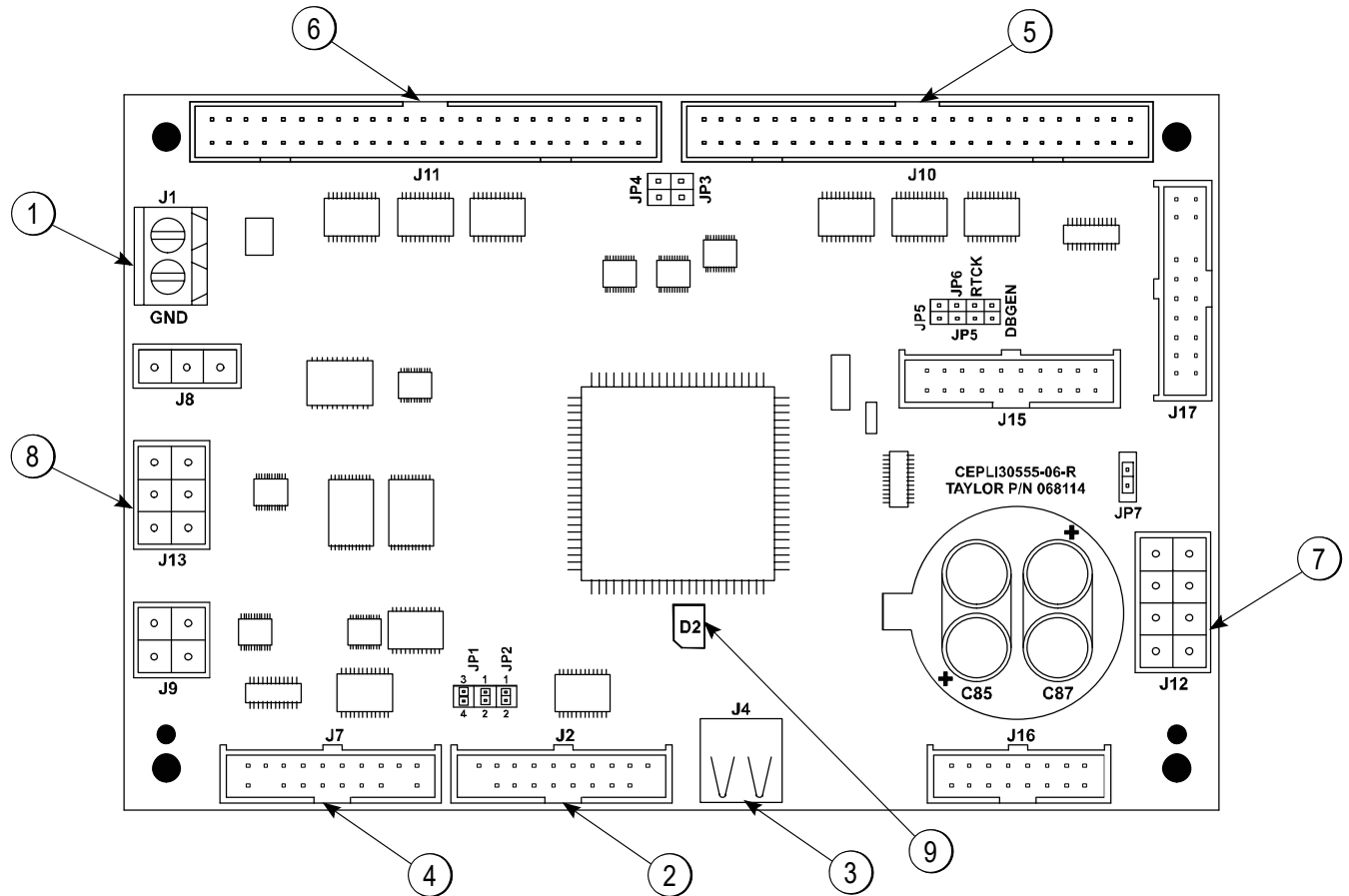

Figure 2-59

The following chart identifies the connections on the board:

Item	Jumper No.	Function
1	J1	5 VDC power input
2	J2	18 pin power loss analog cable
3	J4	USB program port
4	J7	18 pin amp draw and thermistor probe data analog cable
5	J10	50 pin digital cable-leftside

Item	Jumper No.	Function
6	J11	50 pin digital cable-right side
7	J12	Local On-site Network (LON) cable
8	J13	User interface cable
9	D2	Heartbeat LED

**Important!** See "UVC4 Electrostatic Discharge and Proper Handling Procedures" on page 2-22 before handling a UVC4 board.

## Universal Control

The Universal Control is the command center for the machine. The software program for the UVC3 control, including multiple language selections, resides in the erasable programmable read-only memory (EPROM) chip. The EPROM chip is not used on the UVC4 Universal Control.

The settings in the menus are saved in the random access memory (RAM) chip. Removing and reinstalling the software chip will restore the factory default settings in the menus. The RAM chip must be inserted with the notch towards the side of the socket with the notch.

Power is supplied to the 5 VDC terminal on the UVC3/UVC4 board from the interface board. The operating voltage range for the control is 4.75 VDC to 5.25 VDC.

**Note:** *Beginning with software version 1.07, the default settings can be restored in the Service Menu. This can only be done when the unit is in a Unit Cleaned State. The unit must be cleaned or the W-2 on the shake side interface board must be jumped out to enter a Unit Cleaned State. (See "Reset to Defaults" on page 2-12.)*

**Note:** *For installations with low voltage supply (210V or less) it may be necessary to wire the 16 VAC transformer on the low voltage tap. Low voltage supplied to the interface board, in turn reduces the voltage supplied to the UVC3/UVC4 board and may cause intermittent power failure tripping or the control panel keys do not function when the unit is powered.*

The UVC3/UVC4 communicates with the control panel interface board through a USB Cable.

There are three sets of pins on the UVC3 board and four sets of pins on the UVC4 board. Refer to the following chart to identify their function.

**Note:** *Use Part No. 040084-001 Connector-Programming Shunt to jumper pins.*

## Starting Serial Number Built With UVC4

C712/C713      M1060000      X69355-SER

## UVC3 to UVC4 Conversion Kit Part Number

C712/C713      X69355SER1

## UVC4 Electrostatic Discharge and Proper Handling Procedures

The UVC4 board is more susceptible to electrostatic discharge than the UVC3 board. Always use the following procedures to prevent damage when handling the board.

1. Leave boards in their anti-static packaging until they are ready to be installed.
2. Dissipate static electricity before handling the board by touching a grounded metal object, such as the unit's unpainted metal chassis.
3. If possible, use anti-static devices such as wrist straps and floor mats.
4. Always hold the board by its edges. Avoid touching the contacts and components on the board.
5. Take care when connecting or disconnecting cables. A damaged cable can cause a short in the electrical circuit.
6. Prevent damage to the connectors by aligning the connector pins before connecting the cable. Misaligned connector pins can cause damage to components at power-on.
7. When disconnecting a cable, always pull on the cable connector or strain-relief loop, not on the cable itself.

## UVC4 Cables - Factory Installed

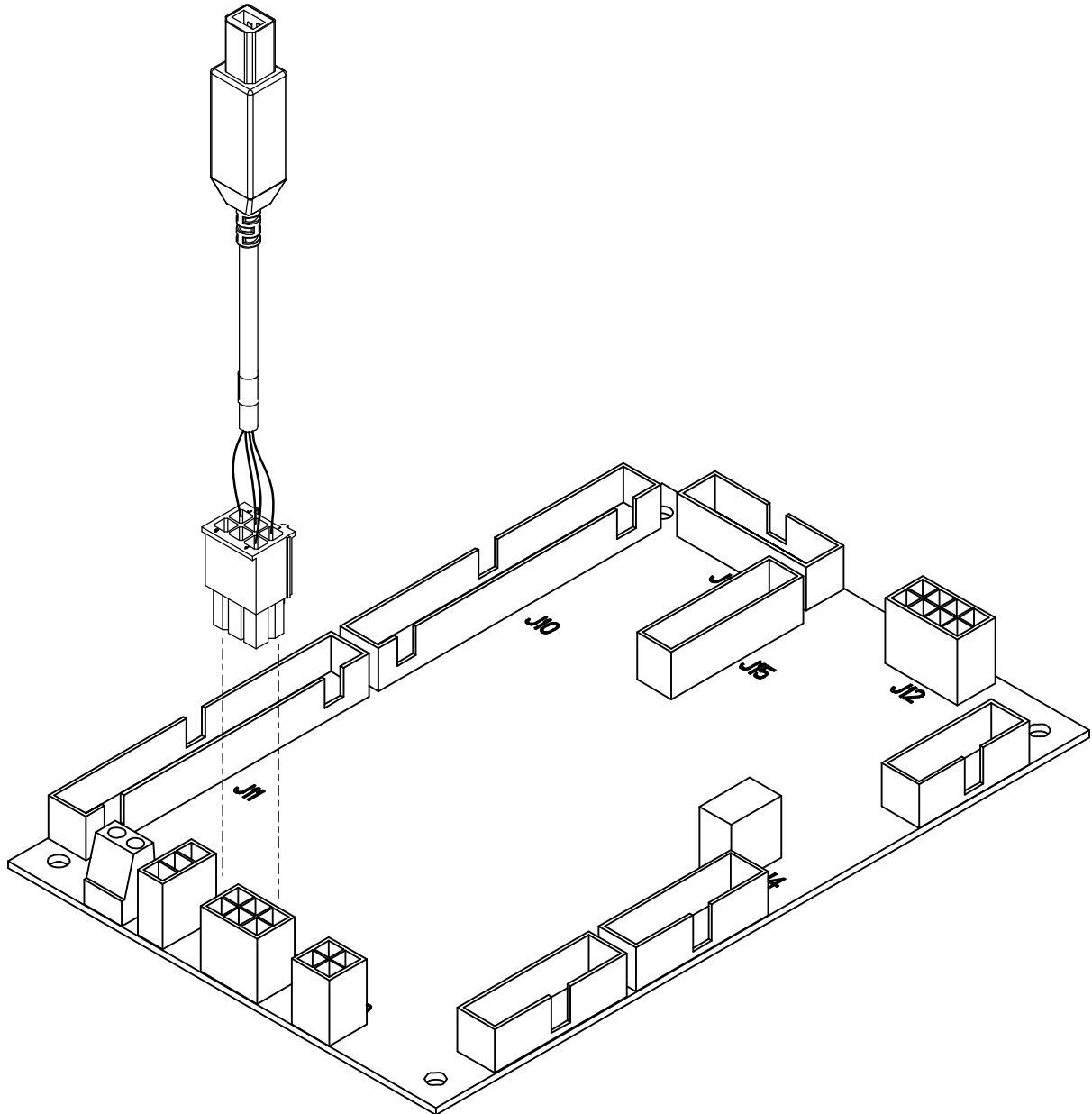

Figure 2-60

Boards installed at the factory have two cables connected to the UVC4 board. Connected at J13 is the USB cable part number 069023.

**Important!** See “UVC4 Electrostatic Discharge and Proper Handling Procedures” on page 2-22 before handling a UVC4 board.

UVC4 Cables - Conversion Kit For Field Replacements

2

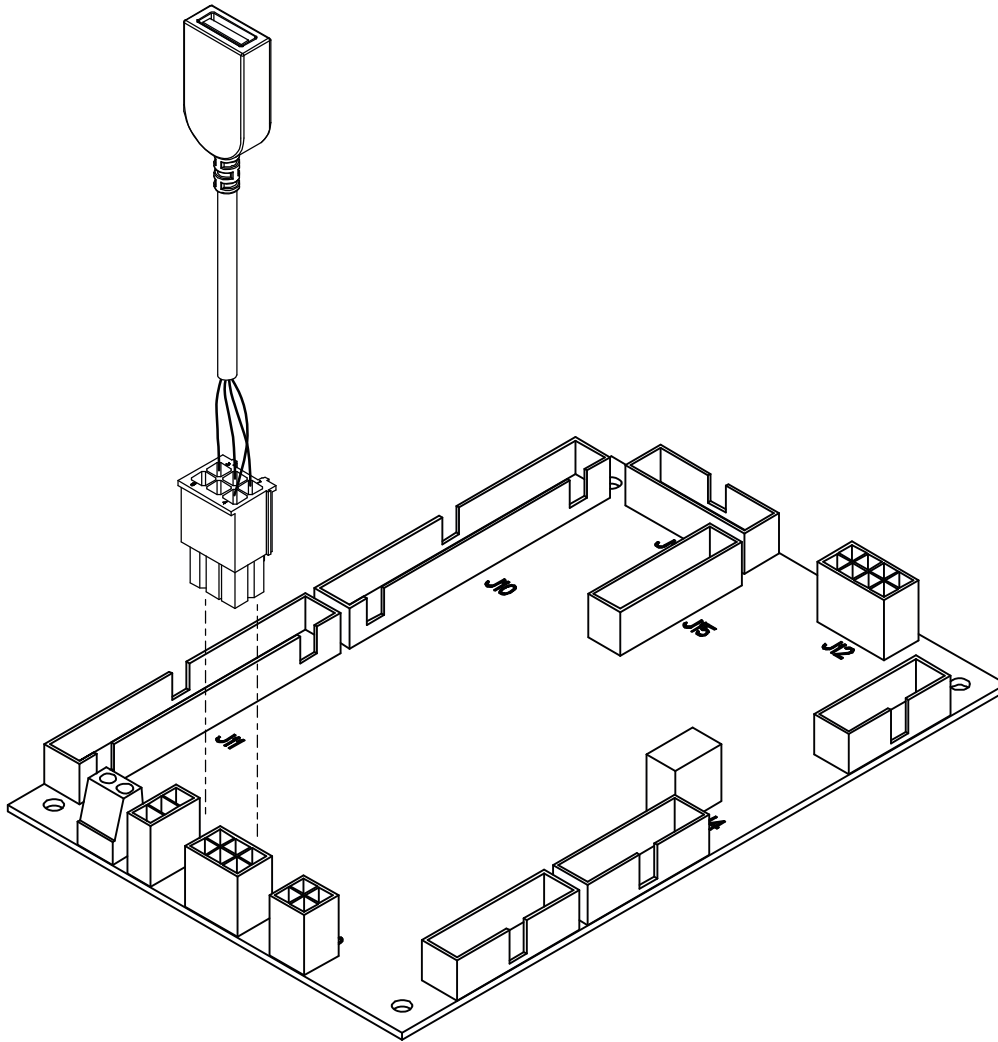

Figure 2-61

The UVC4 board is interchangeable with the UVC3 board. When replacing a UVC3 board in the field, adapter cables are needed. Cable part number 069024 (1) connects to the existing USB cable.

**Important!** See “UVC4 Electrostatic Discharge and Proper Handling Procedures” on page 2-22 before handling a UVC4 board.

## C712/C713 UVC4 Update Instructions

Estimated Time: 35 minutes

### Important!

- See “UVC4 Electrostatic Discharge and Proper Handling Procedures” on page 2-22 before handling a UVC4 board.
  - Before performing software update, reset the control to defaults. This will clear the RAM memory so the new software can be loaded.
  - Only use factory supplied USB drives to perform software update. **Do not** make copies of factory supplied USB drives with generic USB drives. Failure to follow this instruction can cause issues in successfully completing the software update.
  - Wear appropriate personal protective equipment.
1. Enter the Service menu (5231) to copy the current machine settings.
  2. Place both sides of the machine in the OFF mode and turn the syrup heaters off.
  - 3.
  4. Remove the two drip trays from the upper rear of the machine and place them on top of the machine.
  5. Remove the two screws at the bottom of the Panel-Rear-Upper.
  6. Remove the six screws from the Cover-Control Box.
  7. Install a jumper on the W2 on the left side interface board.
  8. Reconnect power to the machine and turn power on. Verify that the display says UNIT CLEANED.
  9. Remove the jumper from W2 on the left side interface board.
  10. Enter the Service Menu and go to the option, Reset to Defaults.
  11. Perform a Reset to Defaults by selecting YES to clear all RAM memory.
  12. Install the USB flash drive in the J4 port on the UVC4 board.
  13. Check jumper position JP7. Remove the jumper, if present, and do not reinstall.
  14. Access the Service Menu. Go to Software Update and select YES to begin update process.
  15. Wait 3 minutes for the software to complete the update.
  16. After the Lamp Test, enter the Service Menu and clear any faults. Reset unit to defaults.
  17. Re-enter all settings copied earlier.
  18. Remove the USB flash drive from the UVC4 board and store it in the tool kit.
  19. Place both sides of the unit in the Auto mode. Turn the syrup heaters back on, if that was the original state before the installation.
  20. Verify both sides of the machine are operating properly (shutting off at proper viscosity and no faults).
  21. Draw at least one soft serve cone per side to verify that the product appearance is acceptable
  22. Carefully reinstall the control box cover, back panel, and drip trays.



**CAUTION!** Disconnect all power to the machine. Failure to follow this instruction may result in electrocution.

# Refrigeration Schematic

2

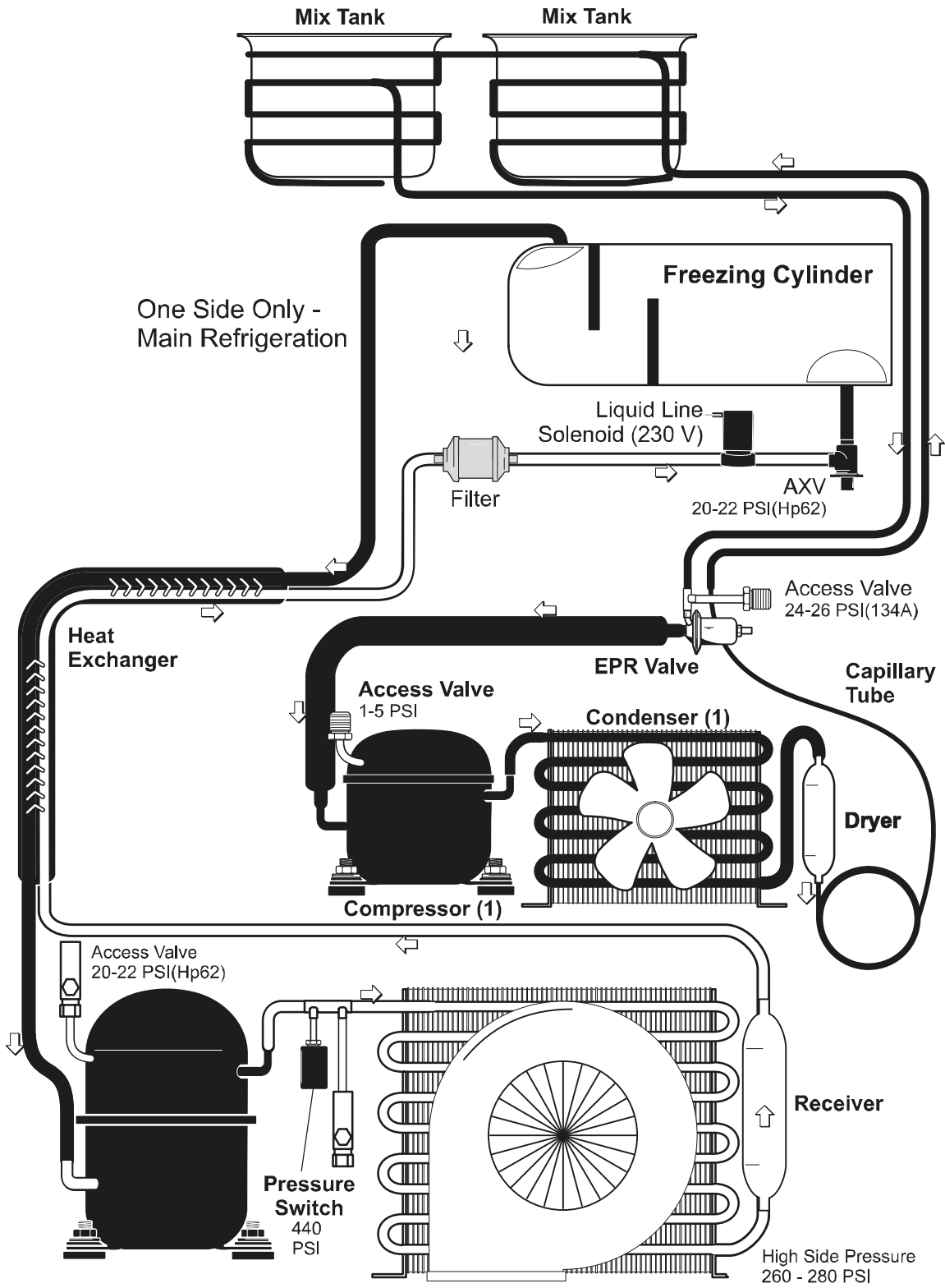

Figure 2-62



## Refrigeration System Components

Comp Label	Description	Function	Basic Operating Logic	Input/Output
Mix Hopper	20 qt. capacity, wrapped with 40' of 5/16" copper tubing	Storage of product mix, evaporator.		
Freezing Cylinder	Conventional, 3.4 qt. flooded evaporator	Freezing of product, evaporator.		
Condenser	Lanced fin	Cooling of compressed refrigerant.		
Fan - Condenser	Motor A.-Fan (Blower)	Provides air flow to remove heat from condenser heat exchanger.	On with the compressor in Auto and Standby. Operates for 30 sec. after the compressor shuts off.	Output
Compressor	Hermetically sealed - Copeland, CS20	Compresses the refrigerant. Used for barrel and hopper cooling in Auto, Standby, and the cooling phase of the heat mode.	Enabled in Auto and Standby. Off in Wash and Off modes.	Output
AXV	Automatic expansion valve for the freezing cylinder - 046365	Controls the refrigerant flow during the cooling of the freezing cylinder.		
Filter/Dryer	Dryer-Filter-HP62-3/8 x 1/4S - 048901	This keeps moisture, dirt, metal, and chips from entering the refrigerant flow control valves.		
Heat Exchanger (sub cooler)	15.25 joined length	This allows the liquid refrigerant to be cooled before it reaches the AXV.	When the liquid is subcooled before it reaches the refrigerant control, the refrigeration effect per unit mass of refrigerant is increased.	
Receiver	Accumulator - 047062	The liquid receiver is a storage tank for liquid refrigerant.	The use of a liquid receiver makes the quantity of refrigerant in a system less critical.	

2



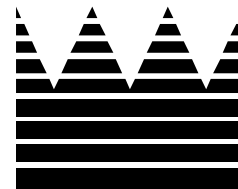

## **Section 3: Troubleshooting**

- **General Troubleshooting Guide**
- **Electrical Troubleshooting Guide**
- **C712/C713 Electrical Troubleshooting Guide**
- **Pump Style Freezer Troubleshooting**
- **Bacteria Troubleshooting**

# General Troubleshooting Guide

Table 3-1

Problem	Probable Cause	Remedy
1. Compressor will not run.	<ul style="list-style-type: none"> <li>a. The power switch is in the OFF position.</li> <li>b. An error has been made in key pad selection.</li> <li>c. The contactor is faulty.</li> <li>d. The compressor has burned out.</li> <li>e. The fuse or circuit breaker has blown.</li> <li>f. Tripped overload (compressor).</li> <li>g. Off on reset (beater motor).</li> </ul>	<ul style="list-style-type: none"> <li>a. Place the switch in the ON position.</li> <li>b. Press the correct key for Auto operation.</li> <li>c. Replace the contactor.</li> <li>d. Replace the compressor.</li> <li>e. Replace the fuse or turn on the breaker.</li> <li>f. Place the power switch in the OFF position. Allow the compressor to cool and the overload to close before returning the power switch to the ON position.</li> <li>g. Press the reset button.</li> </ul>
2. Machine operates long (cycles off on the 11 minute safety timer.	<ul style="list-style-type: none"> <li>a. Dirty condenser.</li> <li>b. Scraper blades are worn.</li> <li>c. Shortage of refrigerant.</li> <li>d. Air in the system.</li> <li>e. High overrun product (C712).</li> </ul>	<ul style="list-style-type: none"> <li>a. Clean the condenser.</li> <li>b. Replace scraper blades.</li> <li>c. Repair the leak and recharge the machine.</li> <li>d. Purge and recharge the system.</li> <li>e. Check pump operation for correct air/mix ratio.</li> </ul>
3. Head pressure is too high.	<ul style="list-style-type: none"> <li>a. Condenser is dirty.</li> <li>b. Water valve is out of adjustment or is restricted.</li> <li>c. Insufficient air space around machine.</li> <li>d. Refrigerant overcharge.</li> <li>e. Blower is faulty.</li> </ul>	<ul style="list-style-type: none"> <li>a. Clean condenser.</li> <li>b. Check the adjustment and the water supply.</li> <li>c. Make sure there is sufficient air space surrounding the machine (see "Specifications").</li> <li>d. Correct refrigerant charge.</li> <li>e. Replace the blower.</li> </ul>
4. Head pressure is too low.	<ul style="list-style-type: none"> <li>a. Refrigerant shortage.</li> </ul>	<ul style="list-style-type: none"> <li>a. Repair leak and recharge.</li> </ul>
5. Liquid line is hot.	<ul style="list-style-type: none"> <li>a. Shortage of refrigerant.</li> </ul>	<ul style="list-style-type: none"> <li>a. Repair leak and recharge.</li> </ul>
6. Excessive mix leakage through the rear of the unit into the drip pan.	<ul style="list-style-type: none"> <li>a. Worn or missing drive shaft seal.</li> <li>b. Inadequate lubrication.</li> <li>c. Drive shaft rotates forward.</li> </ul>	<ul style="list-style-type: none"> <li>a. If worn, nicked, or missing, replace the drive shaft seal.</li> <li>b. Lubricate properly.</li> <li>c. Check gear alignment.</li> </ul>
7. Low overrun.	<ul style="list-style-type: none"> <li>a. Bad scraper blades.</li> <li>b. Faulty air/mix pump components (C712).</li> <li>c. Restricted air intake (air/mix pump) (C712).</li> <li>d. Long ON cycles.</li> </ul>	<ul style="list-style-type: none"> <li>a. Replace scraper blades.</li> <li>b. Inspect air/mix pump components and replace those found faulty.</li> <li>c. Clear restriction.</li> <li>d. See problem 2.</li> </ul>

3

<b>Problem</b>	<b>Probable Cause</b>	<b>Remedy</b>
8. Draw valve leaking.	<ul style="list-style-type: none"> <li>a. Worn or missing draw valve O-rings.</li> <li>b. Inadequate lube on draw valve O-rings.</li> <li>c. Wrong type of lubricate being used.</li> </ul>	<ul style="list-style-type: none"> <li>a. Replace regularly.</li> <li>b. Lubricate properly.</li> <li>c. Use proper lubricant. Example: Taylor Lube High Performance.</li> </ul>
9. Product is not being fed into the freezing cylinder.	<ul style="list-style-type: none"> <li>a. Inadequate mix in the hopper (Mix-Out light is lit).</li> <li>b. Air/mix pump incorrectly assembled (C712).</li> <li>c. Air/mix pump is not operating (C713).</li> </ul>	<ul style="list-style-type: none"> <li>a. Fill hopper with mix.</li> <li>b. Assemble pump according to instructions in the Operator's Manual.</li> <li>c. Follow the correct feed tube procedures and use of the air orifice.</li> </ul>
10. No product being dispensed with draw valve open and machine in AUTO mode.	<ul style="list-style-type: none"> <li>a. Plugged door spout.</li> <li>b. Beater rotating counterclockwise.</li> <li>c. Inadequate mix in the hopper (mix out light is lit).</li> </ul>	<ul style="list-style-type: none"> <li>a. Break down the machine and dislodge the door spout clog.</li> <li>b. Correct beater rotation to clockwise.</li> <li>c. Fill hopper with mix.</li> </ul>
11. Product too soft.	<ul style="list-style-type: none"> <li>a. Not enough air space surrounding machine.</li> <li>b. Bad scraper blades.</li> <li>c. Dirty air-cooled condenser.</li> <li>d. Outdated mix.</li> <li>e. Refrigerant shortage.</li> <li>f. Product viscosity set too warm.</li> <li>g. Incorrect usage of the mix feed tube (C713).</li> </ul>	<ul style="list-style-type: none"> <li>a. Allow 3" (76 mm) minimum clearance around all sides and install the deflector.</li> <li>b. Replace scraper blades.</li> <li>c. Clean monthly.</li> <li>d. Use fresh mix.</li> <li>e. Locate leak and repair.</li> <li>f. Adjust product viscosity.</li> <li>g. Follow the correct feed tube procedures and use of the air orifice.</li> </ul>
12. Plugged door spout.	<ul style="list-style-type: none"> <li>a. Poor scraping.</li> <li>b. Damaged draw valve O-rings.</li> <li>c. Damaged beater assembly.</li> <li>d. Worn rear shell bearing.</li> </ul>	<ul style="list-style-type: none"> <li>a. Replace scraper blades.</li> <li>b. Replace O-rings.</li> <li>c. Inspect and replace if necessary.</li> <li>d. Inspect and replace if necessary.</li> </ul>
13. No freezer operation when placing unit in any mode of operation.	<ul style="list-style-type: none"> <li>a. Machine unplugged.</li> <li>b. Circuit breaker is turned off or fuse is blown.</li> <li>c. Power switch is in the OFF position.</li> </ul>	<ul style="list-style-type: none"> <li>a. Plug in machine.</li> <li>b. Turn on circuit breaker or replace fuse.</li> <li>c. Place power switch in the ON position.</li> </ul>
14. Product too stiff.	<ul style="list-style-type: none"> <li>a. Product viscosity set too cold.</li> <li>b. Incorrectly assembled or malfunctioning air/mix pump (C712).</li> </ul>	<ul style="list-style-type: none"> <li>a. Adjust product viscosity.</li> <li>b. Re-assemble pump or replace faulty components.</li> </ul>
15. Mix in the hopper is too cold.	<ul style="list-style-type: none"> <li>a. Temperature is out of adjustment.</li> </ul>	<ul style="list-style-type: none"> <li>a. Adjust hopper temperature.</li> </ul>
16. Mix in the hopper is too warm.	<ul style="list-style-type: none"> <li>a. Temperature is out of adjustment.</li> </ul>	<ul style="list-style-type: none"> <li>a. Adjust hopper temperature.</li> </ul>

## TROUBLESHOOTING

Problem	Probable Cause	Remedy
17. Drive shaft is stuck in the gear box coupling.	<ul style="list-style-type: none"> <li>a. Corners of the drive shaft, coupling, or both are rounded.</li> <li>b. Mix and lubricant are collected in the drive coupling.</li> </ul>	<ul style="list-style-type: none"> <li>a. Replace the necessary component(s). Do not lubricate the end of the drive shaft.</li> <li>b. Brush clean the rear shell bearing area regularly.</li> </ul>
18. Freezing cylinder walls are scored.	<ul style="list-style-type: none"> <li>a. Bent beater assembly.</li> <li>b. Missing or worn front bearing.</li> <li>c. Scraper blades incorrectly installed.</li> </ul>	<ul style="list-style-type: none"> <li>a. Replace beater.</li> <li>b. Install or replace front bearing.</li> <li>c. Install scraper blades over the appropriate securing pin on the beater assembly.</li> </ul>
19. Product is "popping" when drawn.	<ul style="list-style-type: none"> <li>a. Draw rate set too fast.</li> <li>b. Pump is assembled/lubed incorrectly (C712).</li> <li>c. Freezer has been turned on and off several times.</li> </ul>	<ul style="list-style-type: none"> <li>a. Set the draw rate at 5 oz. to 7-1/2 oz. of product per 10 seconds.</li> <li>b. Assemble pump according to instructions in the Operator's Manual.</li> <li>c. Place the unit in the OFF position only when necessary.</li> </ul>
20. Freezer shuts off and produces a fault tone.	<ul style="list-style-type: none"> <li>a. Fault alert.</li> <li>b. Insufficient air space.</li> </ul>	<ul style="list-style-type: none"> <li>a. Check the fault screen in the operator's menu.</li> <li>b. Allow 3" (76 mm) minimum clearance around all sides and install the deflector.</li> </ul>
21. When Auto is pressed, freezer goes into Standby.	<ul style="list-style-type: none"> <li>a. Mix-out condition.</li> </ul>	<ul style="list-style-type: none"> <li>a. Add mix.</li> </ul>
22. "Compressor On Too Long" fault message.	<ul style="list-style-type: none"> <li>a. Inadequate pump operation (C712).</li> <li>b. The draw rate is set too fast.</li> <li>c. Inadequate air flow.</li> <li>d. Faulty blower baffle.</li> <li>e. Inadequate AXV settings.</li> </ul>	<ul style="list-style-type: none"> <li>a. Check the pump operation. Assemble the pump according to instructions in the Operator Manual.</li> <li>b. Set the draw rate at 5 oz. to 7-1/2 oz. of product per 10 seconds.</li> <li>c. Allow a minimum of 3" (76 mm) around all sides. Install the deflector provided to prevent recirculation of warm air.</li> <li>d. Repair or replace the blower baffle.</li> <li>e. Set AXV at proper setting. (See "Running Specifications.")</li> </ul>
23. Product Door Off message is displayed.	<ul style="list-style-type: none"> <li>a. The door is off or is loose.</li> <li>b. Door switch is faulty.</li> <li>c. The door switch is not properly installed.</li> <li>d. The 24V relay is faulty.</li> <li>e. There is low voltage from the 24V transformer.</li> </ul>	<ul style="list-style-type: none"> <li>a. Install the door and tighten the hand screws.</li> <li>b. Replace the switch.</li> <li>c. Make sure the door switch is fully inserted.</li> <li>d. Replace the relay.</li> <li>e. Check the power supply connections, shorts, replace transformer.</li> </ul>

# Electrical Troubleshooting Guide

## Modes of Operation

Table 3-2

Components	Standby	Wash	Auto	Pump
Compressor	X		X	
Beater Motor	X	X	X	
Fan	X		X	
Air/Mix Pump Motor			X	X
Agitator	X		X	

## C712/C713 Electrical Troubleshooting Guide

### Power Cord Plugged In/Power Switch in the OFF Position

L1 power from the power cord connection travels through the EMI filter to the 16 volt transformer. The transformer supplies 16 VAC to terminals A and B on the interface board.

The interface board sends 5 VDC to terminal J1 on the universal board.

### Power Switch in the ON Position

**3** L1 power from the power cord connection is supplied to the terminals marked L1 on the interface board. To supply power to the L1 terminal on the interface board, L1 travels through the following switches: the power switch, beater motor overload switch, compressor high limit switch and 15 amp fuse.

### Power Switch in the ON Position/Mode Select: Wash mode

With L1 power supplied to the L1 terminal of the interface board, power is supplied through pin 7 of the J6 terminal, beater interlock relay, and to the beater motor contactor coil.

### Power Switch in the ON Position/Mode Select: PUMP

With L1 power supplied to the L1 terminal of the interface board, power is supplied through pin 5 of the J6 terminal to the air/mix pump motor overload and then to the air/mix pump motor.

### Power Switch in the ON Position/Mode Select: Auto mode

Power is sent from the L1 terminal of the interface board through the following pins on the J6 terminal:

- 7 for the beater motor contactor coil
- 5 for the air/mix pump (30 seconds only)
- 1 for the compressor contactor coil

### Power Switch in the ON Position/Mode Select: Auto/Draw Switch Activated

Power is sent from the L1 terminal on the interface board through the following pins on the J6 terminal:

- 7 for the beater motor contactor coil
- 5 for the air/mix pump (The pump runs for 10 seconds after the draw handle is closed.)
- 1 for the compressor contactor coil

At the completion of a draw, the beater motor and compressor are cycled off by the personality board amp monitor.



## Pump Style Freezer Troubleshooting

Table 3-3

Problem	Probable Cause	Remedy
1. Air/mix pump will not operate in the Auto mode when the draw valve is opened.	a. The pump drive motor is off on reset. b. Malfunctioning interface board. c. Faulty pump motor. d. Faulty connection or draw switch.	a. Allow the machine to cool and press the RESET button. b. Replace interface board. c. Replace motor. d. Check connections or replace switch.
2. Excessive pump cylinder wear.	a. Inadequate or incorrect lubrication of pump cylinder. b. Ball crank rotates clockwise.	a. Lubricate properly. b. Rewire ball crank rotation to rotate counterclockwise.
3. Not enough pressure in the freezing cylinder.	a. Malfunctioning draw switch.	a. Reposition or replace the microswitch.

# Bacteria Troubleshooting

Periodic product sampling is taken by a sanitarian. Bacteria counts should not exceed the following figures:

Standard Plate Count (SPC)	50,000
Coliform	10

If the counts exceed the numbers listed, steps should be taken to locate the cause. Failure to solve the high counts will result in an unsafe product for consumption. Educate

the operator about how to prevent high bacteria counts.

**Note:** *High bacteria counts in soft serve yogurt is normal and necessary. Coliform, however, cannot be accepted in any product. The following information will help solve high coliform count problems.*

**Note:** *If sample results indicate a problem, one of these areas may be a source of contamination.*

Table 3-4

Cause Of Contamination	Prevention
1. Human contamination.	<ul style="list-style-type: none"> <li>a. Wash hands and arms past elbows.</li> <li>b. Wear rubber gloves if cuts or skin conditions exist.</li> <li>c. Wash hands periodically throughout the day.</li> </ul>
2. Residue product deposits on mix contact surfaces (milkstone buildup).	<ul style="list-style-type: none"> <li>a. Provide the proper brushes.</li> <li>b. Brush clean all parts and components thoroughly. Ignoring this will allow formation of milkstone, a porous substance which will house bacteria and can lead to contamination of fresh mix.</li> </ul>
3. Worn, damaged, or cracked parts.	<ul style="list-style-type: none"> <li>a. Provide a food grade lubricant (Example: Taylor Lube).</li> <li>b. Inspect O-rings for holes or tears. O-rings, seals and other wear items must be supplied by the freezer company to meet food industry standards.</li> <li>c. During the operating hours, periodically inspect the rear drip pan for excessive leakage.</li> </ul>

3

Cause Of Contamination	Prevention
<p>4. Improper cleaning and sanitation procedures.</p>	<ul style="list-style-type: none"> <li>a. For cleaning procedures, scrub the sink and strainers thoroughly before each use. The level of solution in each basin must allow the largest component to be submerged. Sanitize and prime the freezer prior to freezing the product. After sanitizing a freezer, use fresh mix to flush remaining sanitizer from the freezing cylinder.</li> <li>b. Provide the proper brushes, lubricants, and single-service towels.</li> <li>c. Store sanitizer in a cool, dry place. Use chemicals according to their labels.</li> <li>d. Use a few good employees to follow the cleaning procedure correctly and consistently. Allow the employee uninterrupted time to complete the cleaning procedure.</li> <li>e. Hold sanitizing solution in the hopper and the freezing cylinder for 5 minutes.</li> <li>f. Wash and sanitize the tube of lubricant; after each use, always recap the tube.</li> <li>g. Parts, components, and brushes should be air-dried overnight. Never store the equipment in the storage cooler.</li> <li>h. Do not neglect daily cleaning practices: wipe the external areas of the freezer periodically throughout the day, remove the design caps and sanitize the area, check the drip trays and splash shield.</li> </ul>
<p>5. Mix stored improperly.</p>	<ul style="list-style-type: none"> <li>a. Rotate stock to use older date code mix first. Shelf life of mix is normally 10 days.</li> <li>b. Mix must never be stacked outside or under direct sunlight while waiting to be placed in the cooler.</li> <li>c. Place the mix directly in the cooler. Always leave one inch between the mix and other products to allow air to circulate around the product.</li> <li>d. Mix must not remain at room temperature for long periods of time.</li> <li>e. Hopper storage must maintain a temperature of 39°F (3.9°C). Storage temperatures above 45°F (7.2°C) will allow cell division in as little as 1 hour.</li> <li>f. Once the mix is placed in the hopper, covers must be properly installed to maintain adequate refrigeration and to prevent airborne contaminants from entering the mix.</li> </ul>



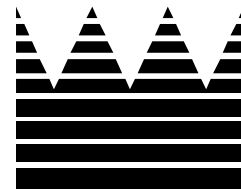

## **Section 4: Parts**

- **Parts Warranty Explanation**
- **Model C712 Exploded View**
- **Operator Parts (Model C712)**
- **Model C713 Exploded View**
- **Operator Parts (Model C713)**
- **Control A. - X67560-27 (Model C712)**
- **Control A. - X67561-27-(Model C713)**
- **Box A.-Cap & Relay - X6540227SP - (Model C712 & C713/Bristol)**
- **Box A.-Cap & Relay - X81081-27 (Model C713/Copeland)**
- **Pump A.-Mix Simplified - X57029- (Model C712)**
- **Door and Beater Assembly (Model C712)**
- **Door and Beater Assembly (Model C713)**
- **Plate A.-Dec (Model C712)**
- **Plate A.-Dec (Model C713)**
- **Rail-Syrup - X63883-27 (Optional)**
- **Switch A.-Dual Lever - X69838 (Model C712 & C713)**
- **Actuator A.-Draw Switch - X69835 (Model C712 & C713)**
- **Blower A. X53725-27 (Model C712 & C713)**
- **Condenser A. - X68077-27G (Model C712 & C713)**
- **Accessories**
- **Brushes (Model C712 & C713)**

## Parts Warranty Explanation

- Class 103 Parts:** The warranty for new equipment parts is one year from the original date of unit installation, with a replacement parts warranty of three months.
- Class 212 Parts:** The warranty for new equipment parts is two years from the original date of unit installation, with a replacement parts warranty of twelve months.
- Class 512 Parts:** The warranty for new equipment parts is five years from the original date of unit installation, with a replacement parts warranty of twelve months.
- Class 000 Parts:** Wear Items—no warranty.

**CAUTION:** Warranty is valid only if required service work is provided by an authorized Taylor service technician.

**Note:** *Taylor reserves the right to deny warranty claims on equipment or parts if a unapproved refrigerant was installed in the machine, system modifications were performed beyond factory recommendations, or it is determined that the failure was caused by neglect or abuse.*

**Note:** *See your authorized Taylor distributor for possible labor warranty.*

# Model C712 Exploded View

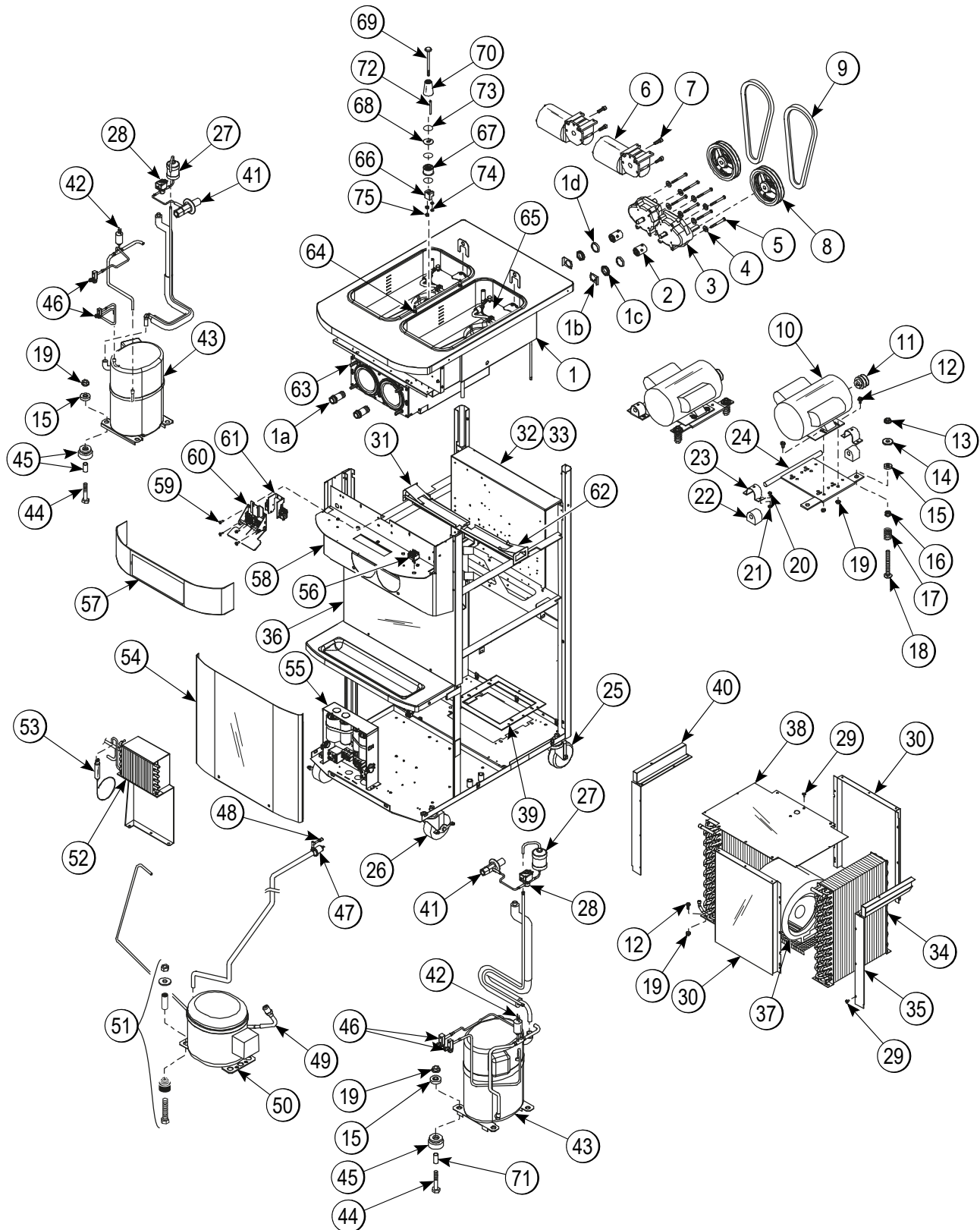

Figure 4-1

# PARTS

## Model C712 Exploded View Parts Identification

Item	Description	Part No.
1	Shell A.-Insulated	X63324-SER
1a	Bearing-Rear Shell	031324
1b	Washer-Bearing Lock	012864
1c	Nut-Bearing	028991
1d	Guide-Drip Seal	028992
2	Coupling-Drive 3/4 Hex	012721
3	Gear A.*Reducer 4.21:1	021286-SER
4	Washer-5/16 SAE Flat	017660-SP
5	Screw-5/16-18X3-1/4 Hex	022678
6	Motor-Reducer-32 RPM	036955-34S
7	Screw-1/4-20X-3/4 Socket	020128-2
8	Pulley-2AK74-5/8	027822
9	Belt-AX32	032769
10	Motor-1.5 HP	021522-27
11	Pulley-2AK22	016403
12	Screw-5/16-18X5/8 SERR.	017326
13	Nut-Flange-5/16-18 Lock	011860
14	Washer-5/16 USS Flat	000651
15	Cap-Rubber Mount	011844
16	Grommet-7/16 X 5/16	016212
17	Spring-Comp.970X.115X2	025707
18	Bolt-Carriage-5/16-18X3	056331
19	Nut-5/16-18 Flange Nut	017327
20	Screw-1/4-20X5/8 SERR	017522
21	Nut-1/4-20 Flange Lock	017523
22	Bushing-Rubber Mount	012258
23	Clamp-Mounting	012257
24	Hinge A.-Motor	X25736
25	Caster-4" SWV 3/4-10 STM	044106
26	Caster-4" SWV w/Brake	046437
27	Dryer-Filter-HP62-3/8	048901
28	Valve-Solenoid 7/64ORF	043449-27
29	Screw-10X3/8 Slotted	015582

Item	Description	Part No.
30	Shroud-Front & Rear	059884
31	Guide A.-Drip Pan-Left	X59910
32	Control A. (See Pg 4-13)	X67560-27
33	Cover-Control Box	067984
34	Condenser-AC Left	055813-1
	Condenser-AC Right	055813-2
35	Guide A.-Filter-Right	X59930
36	Panel A.-Front	X63879
37	Blower A.-Std Output (See Pg 4-27)	X53725-27
38	Shroud-Top	059838
39	Plate-Adaptor-Blower	059926-SP
40	Guide A.-Filter-Left	X59931
41	Valve-Exp-Auto-1/4S X1/4	046365
42	Switch-Pressure 440 PSI	048230
43	Compressor	048259-27E
44	Screw-5/16-18X1-3/4	019691
45	Grommet-Compressor	037428
46	Valve-Access-1/4MFL	053565
47	Valve-EPR 1/4S	022665
48	Valve-Access-1/4FL X 1/4	044404
49	Valve-Access-1/4 MFLX1/4	047016
50	Compressor TL3G-R134A	047701-27
51	Kit-MT-Compressor	047704
52	Condenser A.-Danfoss	X68077-27G See Pg 4-28
53	Dryer-Cap. Tube .026ID	047699
54	Panel A.-Front Lower	X59854-SER
55	Box A.-Cap&Relay	X6540227SP See Pg 4-17
56	Switch-Toggle-3PDT	068221
57	Plate-DEC	062121 See Pg 4-22
58	Panel A.-Front *Upper	X59836



**PARTS**

Item	Description	Part No.
59	Screw-10-32X1/2	048330
60	Actuator A.-Draw Switch	X69835 See Pg 4-26
61	Switch A.-Dual Lever	X69838
62	Guide A.-Drip Pan-Right	X59911
63	Stud-Nose Cone	055987
64	Pin-Retaining-Hopper	043934
65	Pump A.-Mix Simplified S.S.	X57029-14 See Pg 4-19
66	Spacer-Mix Probe	056985

Item	Description	Part No.
67	Spacer-Probe-Mix-Mid	056907
68	Probe-Mix Out	056908
69	Probe A.-Mix	X56912
70	Spacer-Probe-Mix-Upper	056910
71	Sleeve-Mounting-Comp.	039924
72	Screw-10-32X2-1/4 Slot	057610
73	O-ring-1-3/8 OD X .070W	017395
74	Nut-10-32 Hex Screw	005598
75	Nut-1/4-20 Finished Hex	000707

# Operator Parts (Model C712)

4

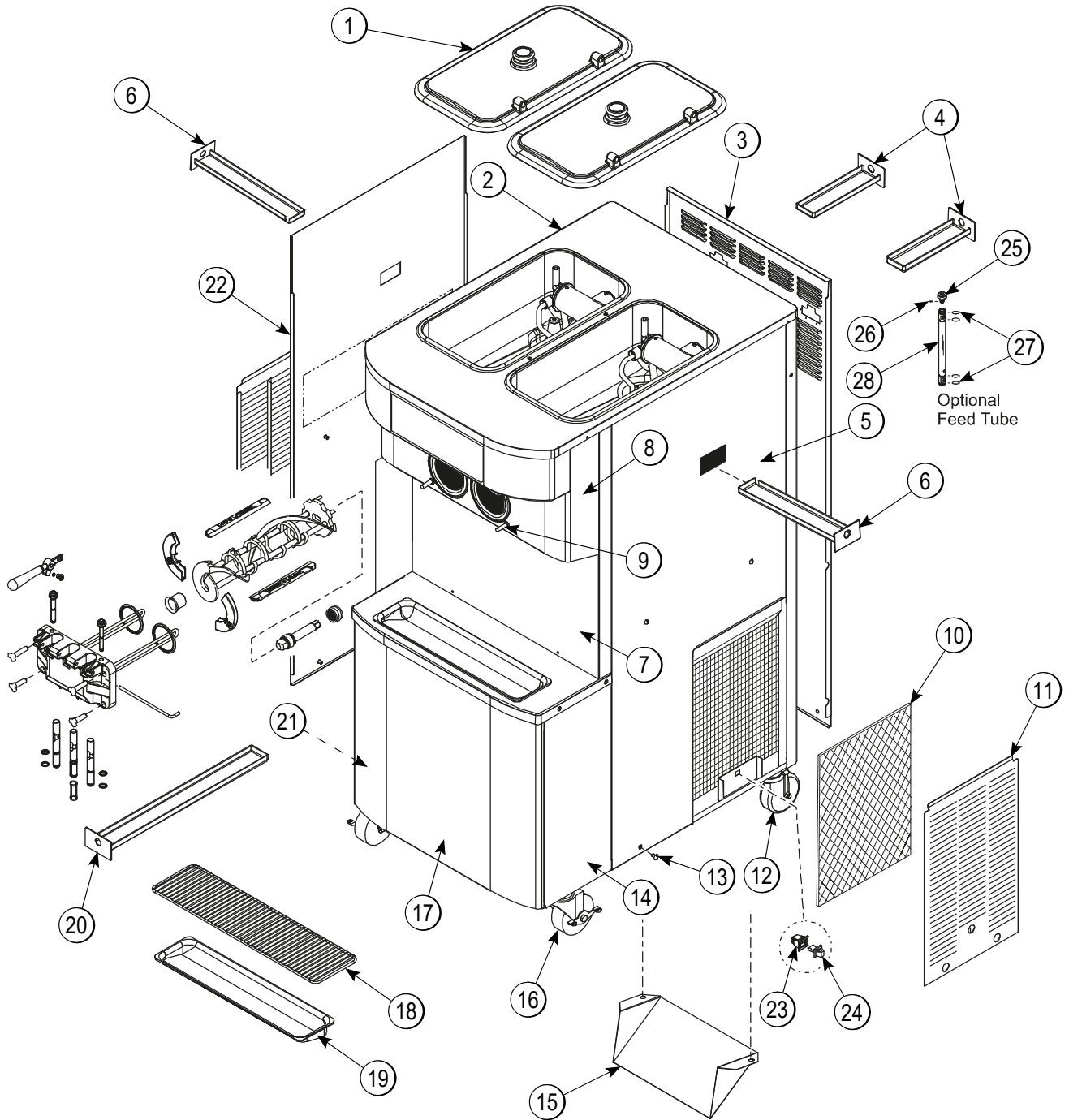

Figure 4-2

## C712 Exploded View Parts Identification

Item	Description	Part No.
1	Kit A.-Cover-Hopper*Dual	X67061-SP
2	Pump A.-Mix Simplified	X57029-14
3	Panel-Rear	064258-SER
4	Pan-Drip 7.875	059737
5	Panel-Side*Right	059907
6	Pan-Drip 12.5	059736
7	Panel A.-Front-Middle	X63879
8	Panel A.-Front-Upper	X59836
9	Stud-Nose Cone	055987
10	Filter-Air-Poly-Flo	052779-11
11	Panel A.-Filter-Louvered	X59928
12	Caster-4" SWV 3/4-10 STM	044106
13	Screw-1/4-20 X 3/8 RHM	011694
14	Panel-Corner-Front-R	063087
15	Deflector-Blower EXH	047912

Item	Description	Part No.
16	Caster-4" SWV 3/4-10 Stem w/ Brake	046437
17	Panel A.-Front Lower	X59854-SER
18	Shield-Splash-Wire-19-3/4 L	033813
19	Tray-Drip-19-5/8 L X 4-7/8	033812
20	Pan-Drip 19-1/2 Long	035034
21	Panel-Corner-FRNT-L	063088
22	Panel-Side-Left	059906
23	Fastener-Door Latch	030787
24	Fastener-Door Strike	030788
*25	Orifice	022465-100
*26	O-ring-3/8 OD X .070W (100 to Bag)	016137
*27	O-ring-.643 OD X .077W (50 to Bag)	018572
*28	Tube A.-Feed-SS-5/32 Hole	X29429-2

\*Optional Feed Tube - Can be used instead of mix pump.

# Model C713 Exploded View

4

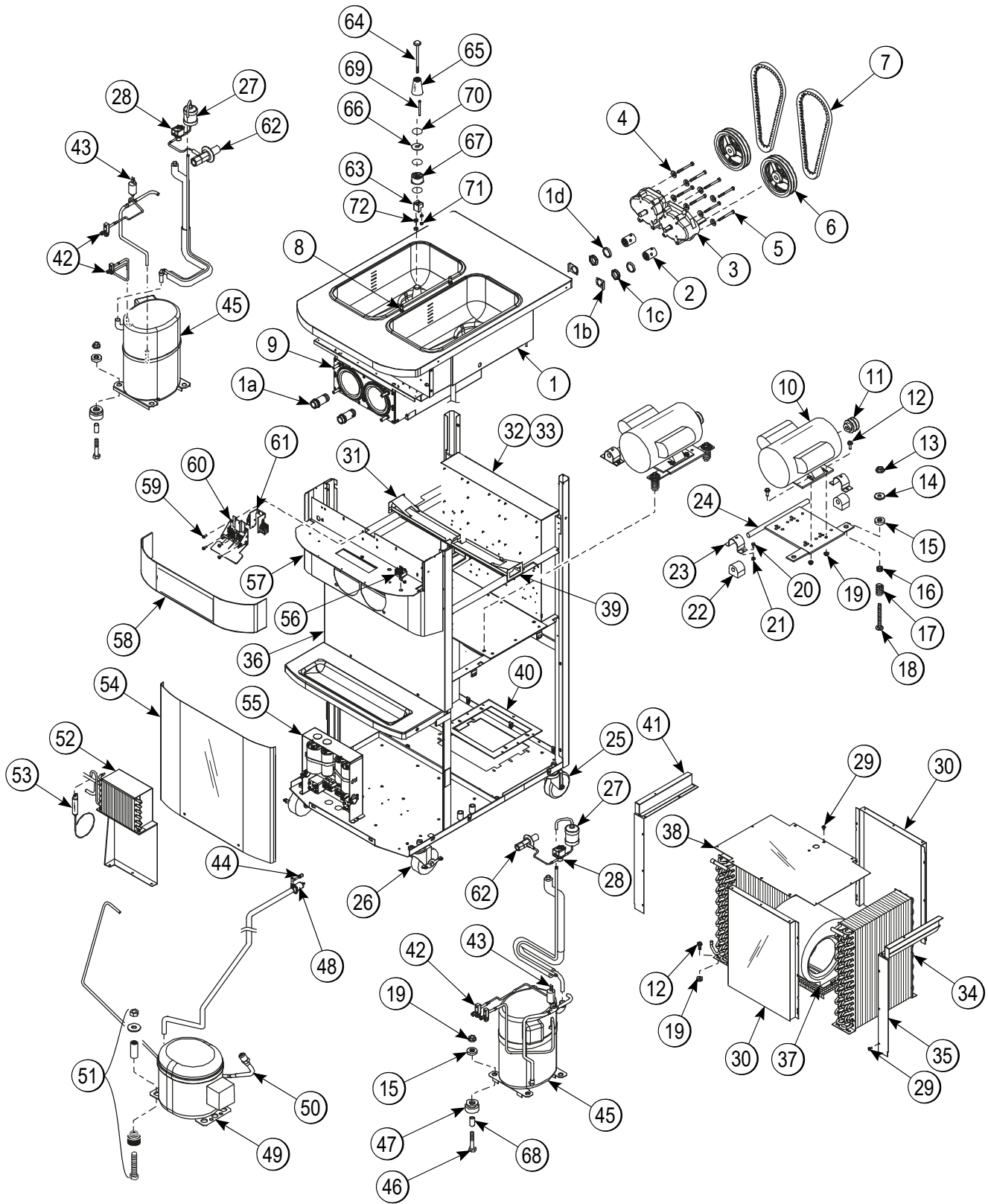

Figure 4-3

## Model C713 Exploded View Parts Identification

Item	Description	Part No.
1	Shell A.-Insulated	X63337-SER
1a	Bearing-Rear Shell	031324
1b	Washer-Bearing Lock	012864
1c	Nut-Bearing	028991
1d	Guide-Drip Seal	028992
2	Coupling-Drive 3/4 Hex	012721
3	Gear A.*Reducer 4.21:1	021286-SER
4	Washer-5/16 SAE Flat Zinc	017660-SP
5	Screw-5/16-18X3-1/4 Hex HD	022678
6	Pulley-2AK64-5/8 Bore	039695
7	Belt-AX30	052191
8	Pin-Retaining-Hopper CVR	043934
9	Stud-Nose Cone	055987
10	Motor-1.5 HP	021522-27
11	Pulley-2AK22	016403
12	Screw-5/16-18X7/8 SERR.	017973
13	Nut-Flange-5/16-18 Lock	011860
14	Washer-5/16 USS Flat CR3	000651
15	Cap-Rubber Mount	011844
16	Grommet-7/16 X 5/16	016212
17	Spring-Comp.970X.115X2.00	025707
18	Bolt-Carriage-5/16-18X3	056331
19	Nut-5/16-18 Whiz Flange	017327
20	Screw-1/4-20X5/8 Serrated	017522
21	Nut-1/4-20 Flange Lock	017523
22	Bushing-Rubber Mount	012258
23	Clamp-Mounting	012257
24	Hinge A.-Motor	X25736
25	Caster-4" SWV 3/4-10 Stem	044106
26	Caster-4" SWV 3/4-10 Stem w/ Brake	046437
27	Dryer-Filter-HP62-3/8	048901
28	Valve-Solenoid 7/64ORF	043449-27
29	Screw-10X3/8 Slotted Hex	015582

Item	Description	Part No.
30	Shroud-Front & Rear	059884
31	Guide A.-Drip Pan-Left	X59910
32	Control A. (See Pg 4-15)	X67561-27
33	Cover-Control Box	067984-SP1
34	Condenser-AC (Left)	055813-1
	Condenser-AC (Right)	055813-2
35	Guide A.-Filter-Right	X59930
36	Panel A.-Front	X63879
37	Blower A.-Std Output	X53725-27
37a	Motor-Fan 208-230V 50/60	053481-27
37b	Capacitor-Run 7.5UF/370V	034749
38	Shroud-Top	059838
39	Guide A.-Drip Pan-Right	X59911
40	Plate-Adaptor-Blower	059926-SP
41	Guide A.-Filter-Left	X59931
42	Valve-Access-1/4MFL X 3/8	053565
43	Switch-Pressure 440 PSI	048230
44	Valve-Access-1/4FL X 1/4	044404
45	Compressor L64A113BBCA	048259-27E
46	Screw-5/16-18X1-3/4	019691
47	Grommet-Compressor MT	037428
48	Valve-EPR 1/4S	022665
49	Compressor TL3G-R134A	047701-27
50	Valve-Access-1/4 MFLX1/4	047016
51	Kit-Mounting-Compressor	047704
52	Condenser A.-Danfoss	X68077-27G See Pg 4-28
53	Dryer-Cap. Tube .026ID	047699
54	Panel A.-Front Lower	X59854-SER
55	Box A.-Cap&Relay *Bristol	X6540227SP See Pg 4-17
56	Switch-Toggle-3PDT	068221
57	Panel A.-Front *Upper	X59836
58	Plate-DEC	062122 See Pg 4-23

## PARTS

---

Item	Description	Part No.
59	Screw-10-32X1/2 Torx	048330
60	Actuator A.-Draw Switch	X69835 See Pg 4-26
61	Switch-Lever-SPDT-10A-125	028889
62	Valve-Exp-Auto-1/4S X1/4	046365
63	Spacer-Mix Probe	056985
64	Probe A.-Mix	X56912
65	Spacer-Probe-Mix-Upper	056910

Item	Description	Part No.
66	Probe-Mix Out	056908
67	Spacer-Probe-Mix-Middle	056907
68	Sleeve-Mounting-Comp.	039924
69	Screw-10-32X2-1/4 Slot	057610
70	O-ring-1-3/8 OD X .070W	017395
71	Nut-10-32 Hex Screw	005598
72	Nut-1/4-20 Finished Hex	000707

# Operator Parts (Model C713)

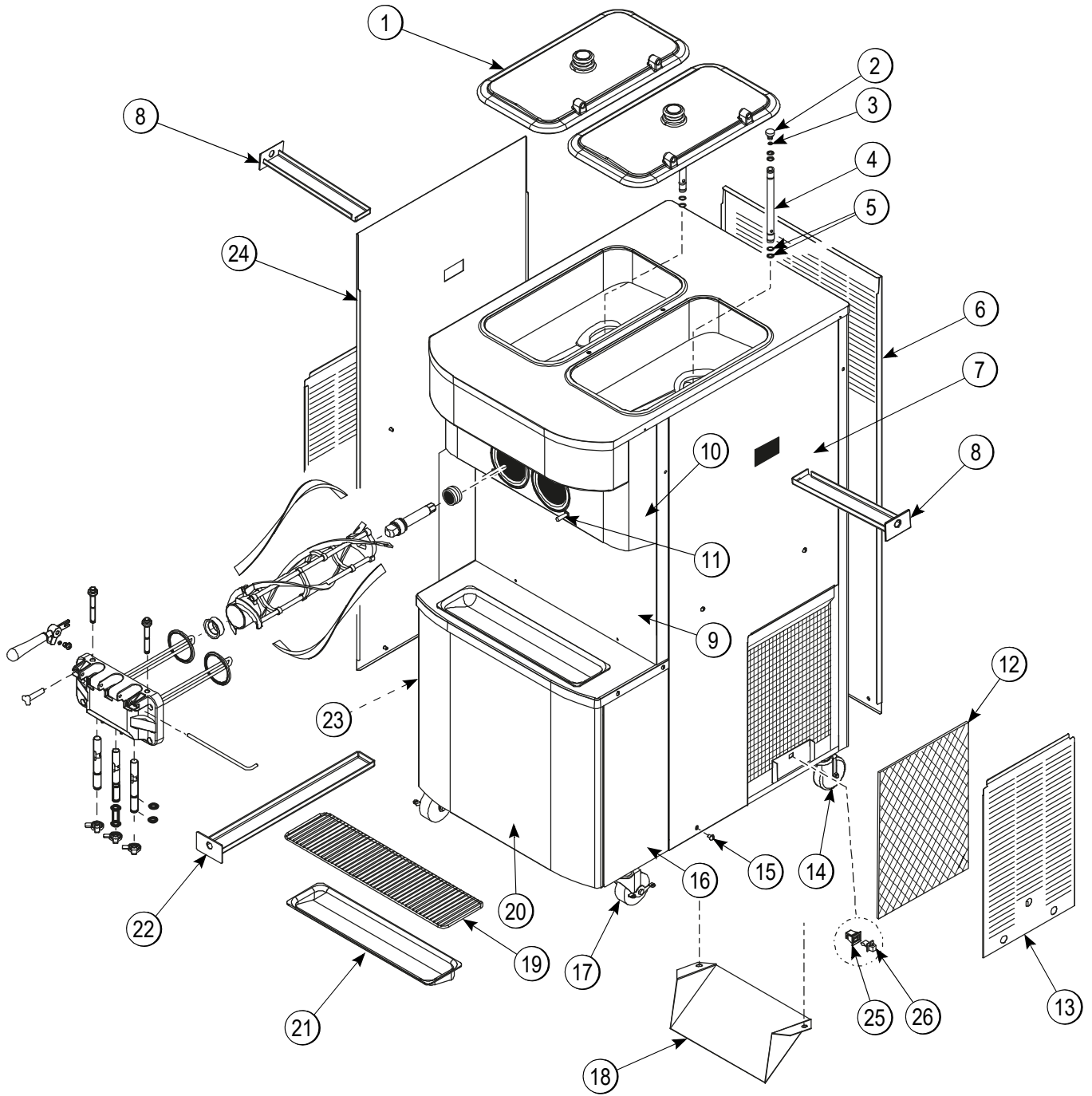

4

Figure 4-4

# PARTS

## C713 Exploded View Parts Identification

Item	Description	Part No.
1	Kit A.-Cover-Hopper	X67061-SP
2	Orifice	022465-100
3	O-ring-Pkg (100 to Bag)	016137-SER
4	Tube A.-Feed-SS-5/32 Hole	X29429-2
5	O-ring-.643 OD X .077 W	018572
6	Panel-Rear	059917
7	Panel-Side*Right	059907
8	Pan-Drip 12.5	059736
9	Panel A.-Front	X63879
10	Panel A.-Front	X59836
11	Stud-Nose Cone	055987
12	Filter-Air-Poly-Flo	052779-11
13	Panel A.-Filter-Louvered	X59928

Item	Description	Part No.
14	Caster-4" SWV 3/4-10 STM	044106
15	Screw-1/4-20 X 3/8 RHM	011694
16	Panel-Corner-Fmt-R	063087
17	Caster-4" SWV w/Brake	046437
18	Deflector-Blower	047912
19	Shield-Splash-Wire-19-3/4 L	033813
20	Panel A.-Front Lower	X59854-SER
21	Tray-Drip-19-5/8 L X 4-7/8	033812
22	Pan-Drip 19-1/2 Long	035034
23	Panel-Corner-Fmt-L	063088
24	Panel-Side-Left	059906
25	Fastener-Door Latch	030787
26	Fastener-Door Strike	030788

4



# Control A. - X67560-27 (Model C712)

4

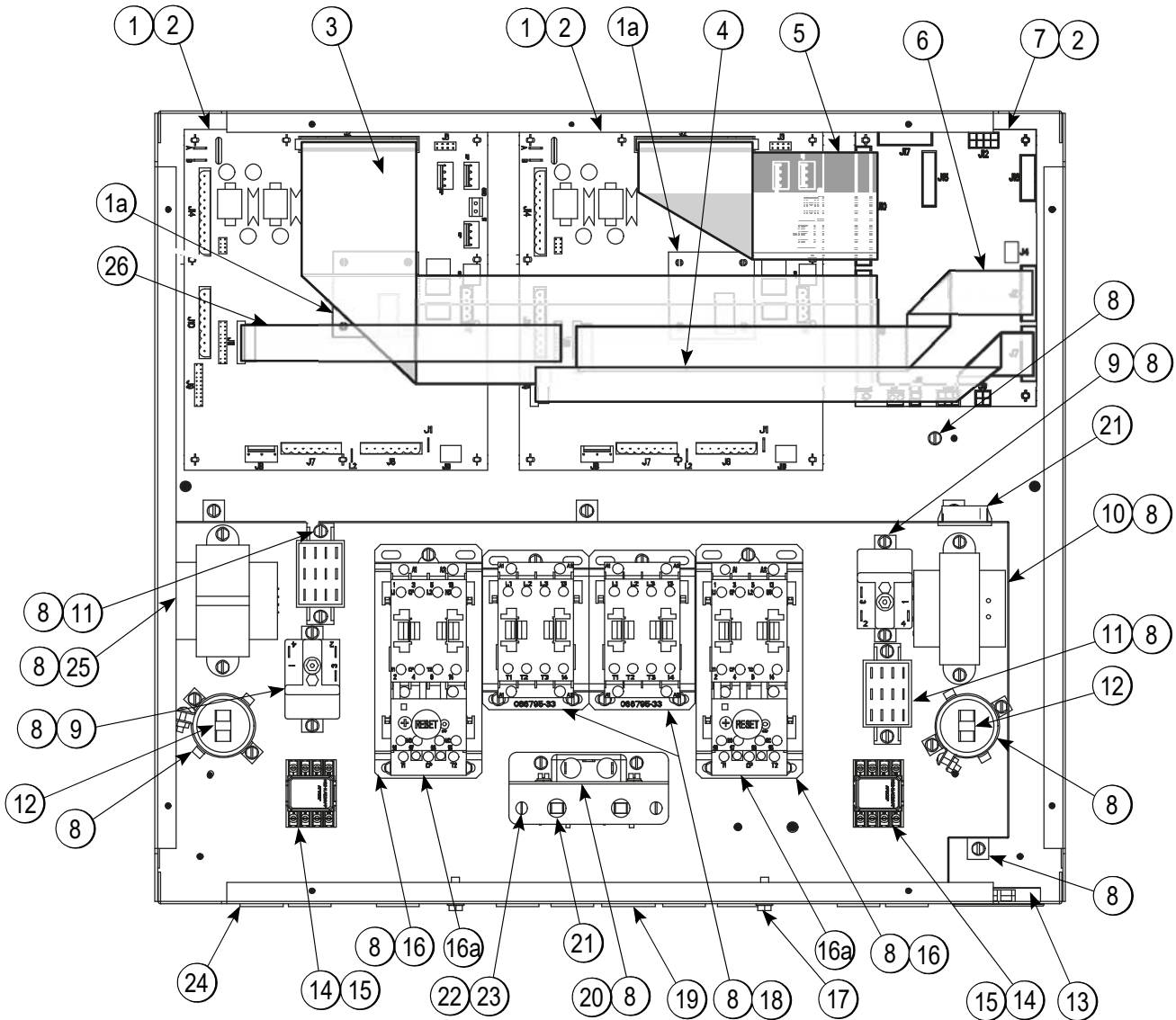

Figure 4-5

## PARTS

### Control Assembly X67560-27 (C712) Parts Identification

Item	Description	Part No.
1	Control-INTERF-HT-SS	063967-SER
1a	PCB A.-ROHS-Person-HT-SS	063922-SER
*1b	Cntrl-ROHS-INTF-Hotgas	063926-SER
2	Standoff-Nylon-Snap-1/2L	053413
3	Cable-Ribbon-50C-25"L	040040-025
4	Cable-Ribbon-20C-16"L	040040-049
5	Cable-Ribbon-50C-10"L	040040-058
6	Cable-Ribbon-20C-14"L	040040-040
7	PCB A.-Control *UVC4	X69355-SER
7a	Control-UVC4 (Base Board)	X68114-SER
8	Screw-8x1/4 SLTD Hex	009894
9	Relay-MTR Start TI#4CR	039725-27
10	Trans.-120/208/240V	051660
11	Block-Terminal 1P	073423
12	Capacitor-Start 47-56UF	037251-34
13	Bushing-Snap 1-5/8ID x 2 OD	043637
14	Relay-DPDT 100UA-7A 1/8HP	052111-03

Item	Description	Part No.
15	Screw-6x5/16 SLTD Round	013646
16	Starter-1 Phase 6.3 to 10A	066794-27K
16a	Overload-Thermal-1P	067461-1K
17	Screw-10-32x5/8 UN SL HWH	039382
18	Relay-3 POLE-20A-208/240	066795-33
19	Bushing-Snap 15/16 ID	023396
20	Filter-Corcom 6EH1	040140-001
21	Overload-Thermal-Remot	067965
22	Nut-6-32 KEPS Nut 18-8 SS	054431
23	Screw-6-32x3/8 SLTD Bind	002201
24	Bushing-Snap 11/16 ID x 7/8	010548
25	Trans.-Cont.-32VA 120	054834
26	Cable-Ribbon-20C-17"L	040040-013
*27	Harness-Wire-Cntrl Box	068007
**	Holder-Fuse-Inline-HFA	064538
**	Fuse-Buss-ABC-15-R ROHS	076414

\*Not Shown

\*\*Not Included in X67560-27

# Control A. - X67561-27-(Model C713)

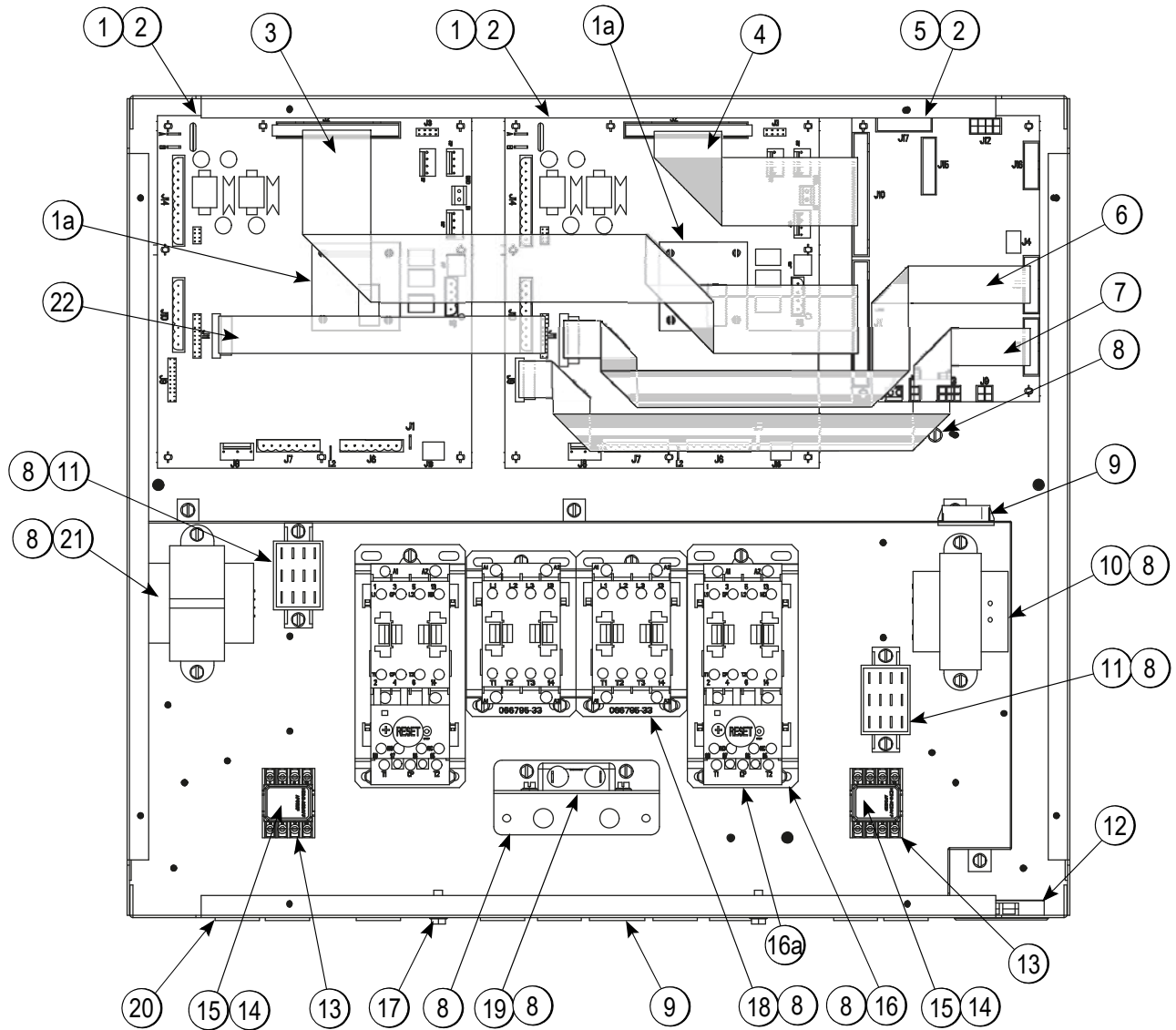

Figure 4-6

4

# PARTS

## Control Assembly X67561-27 (C713) Parts Identification

Item	Description	Part No.
1	Control-INTERF-HT-SS	063967-SER
1a	PCB A.-ROHS-Person-HT-SS	063922-SER
*1b	Cntrl-ROHS-INTF-Hotgas	063926-SER
2	Standoff-Nylon-Snap-1/2L	053413
3	Cable-Ribbon-50C-25"L	040040-025
4	Cable-Ribbon-50C-10"L	040040-058
5	PCB A.-Control *UVC4	X69355-SER
5a	Control-UVC4 (Base Board)	X68114-SER
6	Cable-Ribbon-20C-14"L	040040-040
7	Cable-Ribbon-20C-16"L	040040-049
8	Screw-8X1/4 SLTD Hex	009894
9	Bushing-Snap 15/16 ID	023396
10	Trans.-120/208/240V	051660
11	Block-Terminal 1P	073423

Item	Description	Part No.
12	Bushing-Snap 1-5/8ID X 2 OD	043637
13	Harness-Wire-Cntrl Box	068007
14	Screw-6X5/16 SLTD Round	013646
15	Relay-DPDT 100UA -7A 1/8HP	052111-03
16	Starter-1 Phase 6.3 to 10A	066794-27K
16a	Overload-Thermal-1P	067461-1K
17	Screw-10-32X5/8 UN SL HWH	039382
18	Relay-3 Pole-20A-208/240	066795-33
19	Filter-Corcom 6EH1	040140-001
20	Bushing-Snap 11/16 ID X 7/8	010548
21	Trans.-Cont.-32VA	054834
22	Cable-Ribbon-20C-17"L	040040-013
*	Holder-Fuse-Inline-HFA	064538
*	Fuse-BUSS-ABC-15-R ROHS	076414

\*Not Shown, Not Included in X67561-27

# Box A.-Cap & Relay - X6540227SP - (Model C712 & C713/Bristol)

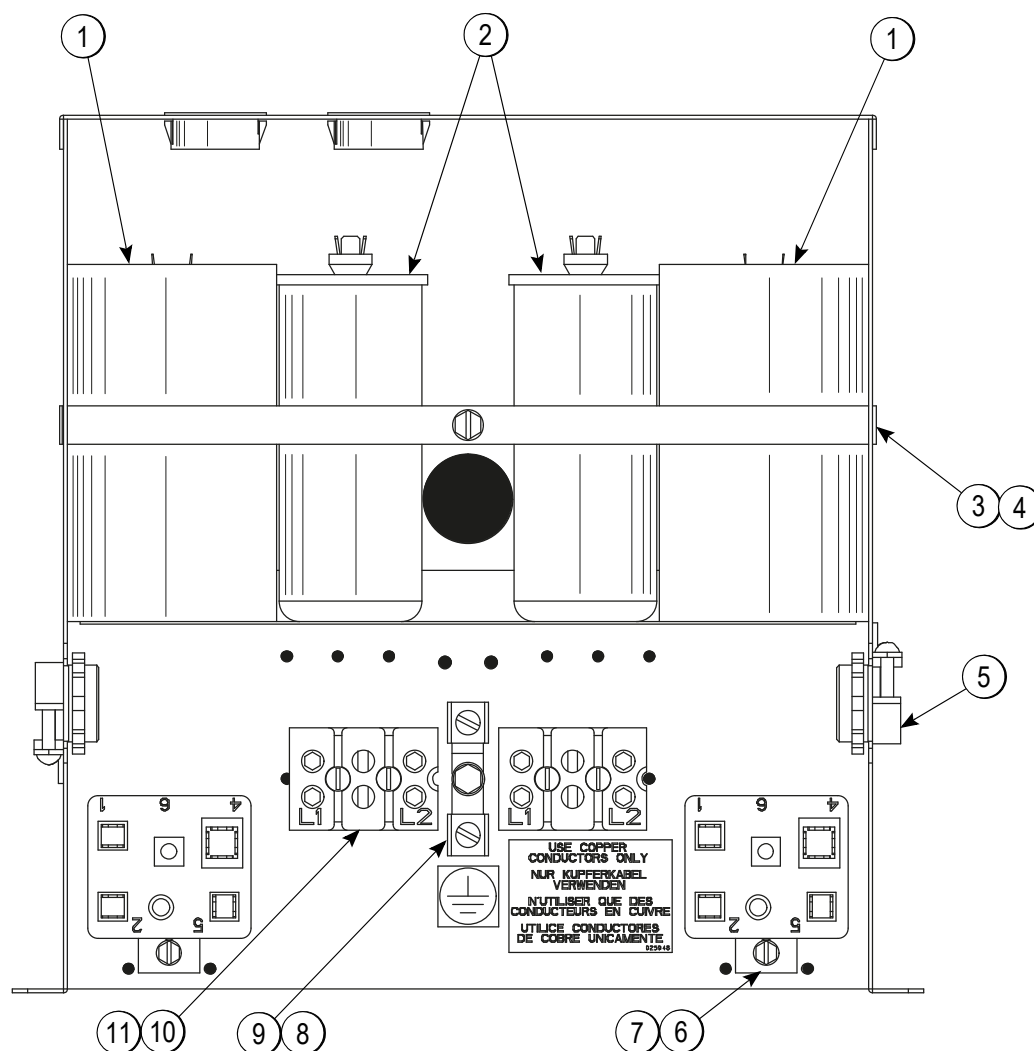

Figure 4-7

Item	Description	Part No.
1	Capacitor-Start 189-227UF	033044-1
2	Capacitor-Run 25UF/440V	037431
3	Strap-Capacitor 7-11/32	037890
4	Screw-10x3/8 Slotted Hex	015582
5	Harness-Wire	06543627SP
6	Relay-Start-Compressor	062363

Item	Description	Part No.
7	Screw-8x1/4 SLTD Hex	009894
8	Lug-Grounding	017667
9	Screw-10-32x3/8 UNSL	039381
10	Block-Terminal 2P L1,L2	039422
11	Screw-8x1 1/4 PHLP HD RD B	039420

# Box A.-Cap & Relay - X81081-27 (Model C713/Copeland)

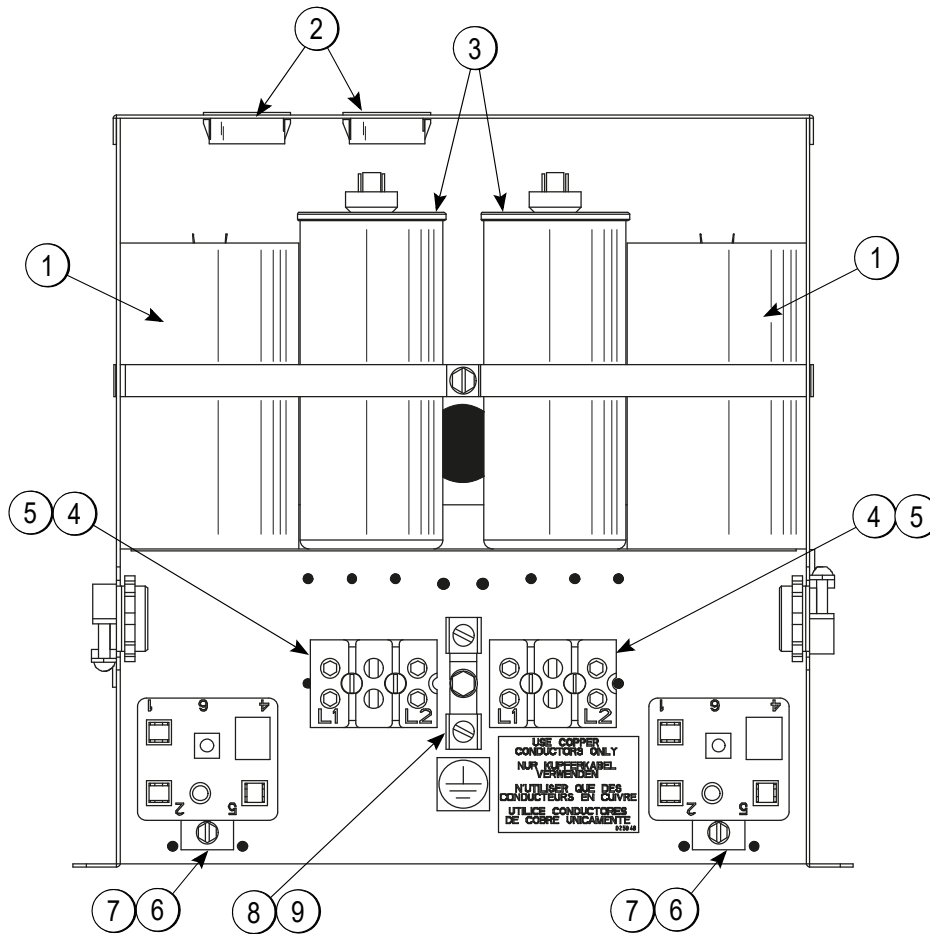

Figure 4-8

Item	Description	Part No.
1	Capacitor-Start 189-22UF	033044-1
2	Plug-Hole 1.093/1.125 DIA	049187
3	Capacitor-Run 40MF/440V	036049
4	Screw-8x1 1/4 PHLP HD RD B	039420
5	Block-Terminal 2P L1,L2	039422

Item	Description	Part No.
6	Screw-8x1/4 SLTD Hex	009894
7	Relay-Start-Compressor	052401-27
8	Lug-Grounding 4-14GA	017667
9	Screw-10-32x3/8 UNSL HWH	039381
*	Harness-Wire	06543627SP

\*Not Shown

4

## Pump A.-Mix Simplified - X57029- (Model C712)

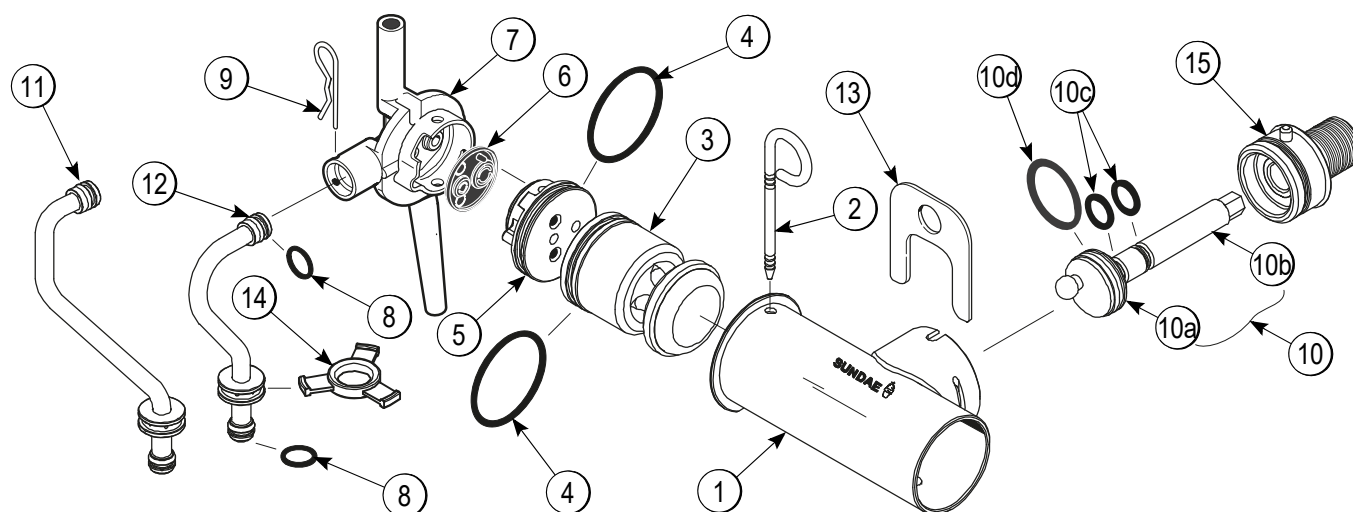

Figure 4-9

Item	Description	Part No.
1-7	Pump A.-Mix Simplified S.S.	X57029-14*
1	Cylinder-Pump Hopper	057943
2	Pin-Retaining	X55450
3	Piston-Pump-Simplified	053526
4	O-ring-2-1/8 OD x .139W-#225	020051
5	Cap-Valve Body SS	056874-14*
6	Gasket-Simplified Pump Valve	053527
7	Adaptor-Mix Inlet-SS-Red	054825
8	O-ring-11/16ODX.103W-Red	016132
9	Pin-Cotter-Hairpin-1/8DIA	044731
10	Shaft A.-Drive-Mix Pump- Hopper	X41947
10a	Crank-Drive-Hopper Mix Pump	039235

Item	Description	Part No.
10b	Shaft-Drive-Mix Pump- Hopper	041948
10c	O-ring 1/2 ID x .139W-Shaft	048632
10d	O-ring-1-3/4 OD x .139W- Crank	008904
11	Tube A.-Feed-Left	X59808
12	Tube A.-Feed-Right	X59809
13	Clip-Retainer-Mix Pump	044641
14	Ring-Check-Feed-Tube	056524
**15	Sleeve A.-Mix Pump *HT	X44761

**Note:** The standard pump is X57029-14. Overrun can be changed higher or lower by substituting the valve body cap. The higher the (-), the higher the overrun. Your machine Includes 2 Optional Caps, 056874-12 and 056874-16.

\*\*Not Included with X57029-14

# Door and Beater Assembly (Model C712)

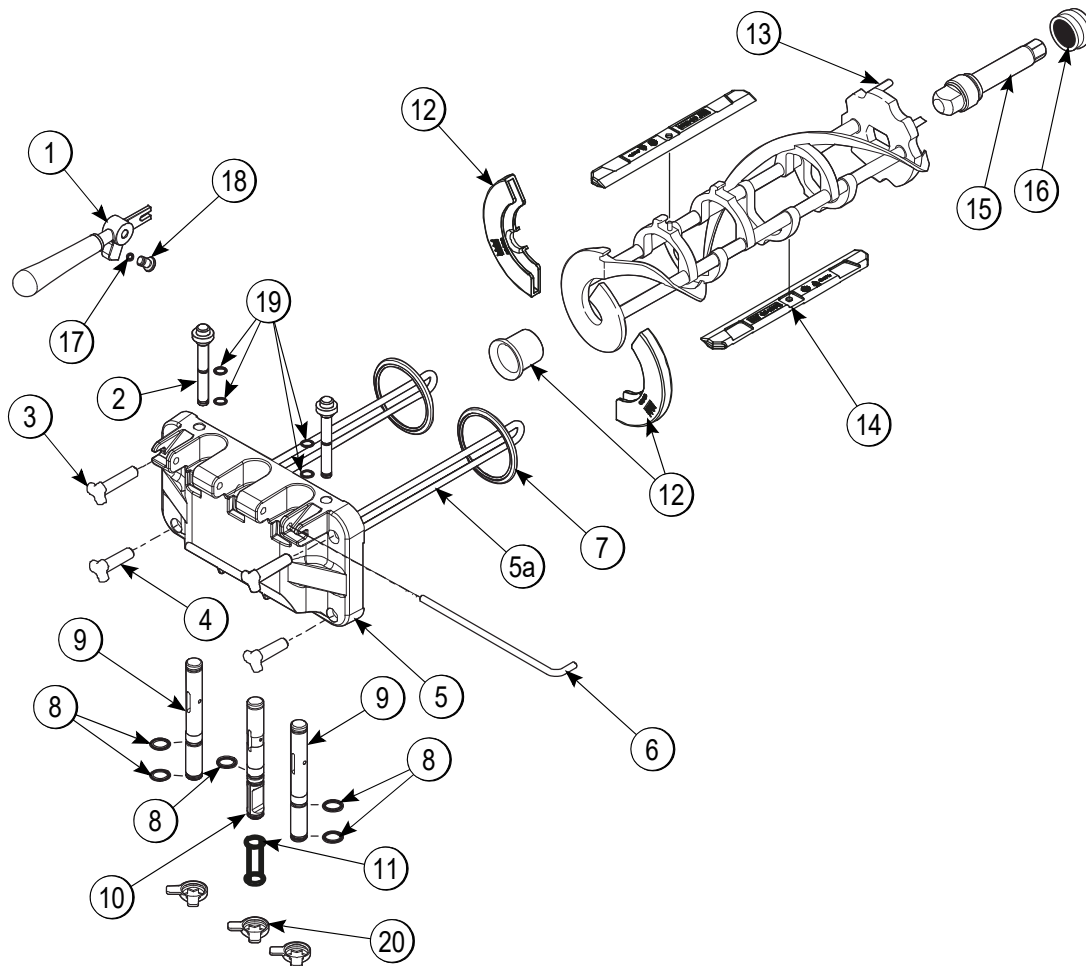

Figure 4-10

Item	Description	Part No.
1	Handle A.-Draw-Welded	X56421-1
2	Plug-Prime Twin	059936
3	Nut-Stud-Black 3.250 Long	058765
4	Nut-Stud-Black 2.563 Long	058764
5	Door A.-3SPT*LG BAF	X59921-SER
5a	Baffle A.-Long 4 IN	X50882
6	Pin-Handle-Twin	059894
7	Gasket-Door HT 4"-Double	048926
8	O-ring-7/8 OD X .103W-SIL	083693
9	Valve A.-Draw	X69615
10	Valve A.-Draw-Center	X62218

Item	Description	Part No.
11	Seal-Draw Valve	034698
12	Kit A.-Beater-Front Shoes-Bearing	X50350
13	Beater A.-3.4QT-1 Pin	X46231
14	Blade-Scraper-Plastic	084350
15	Shaft-Beater	032564
16	Seal-Drive Shaft	032560
17	O-ring-1/4 OD X .070W 50	015872
18	Screw-Adjustment-5/16-24	056332
19	O-ring-.500 OD X .070W	024278
20	Cap-Design 1.010"ID-6 Point	014218



## Door and Beater Assembly (Model C713)

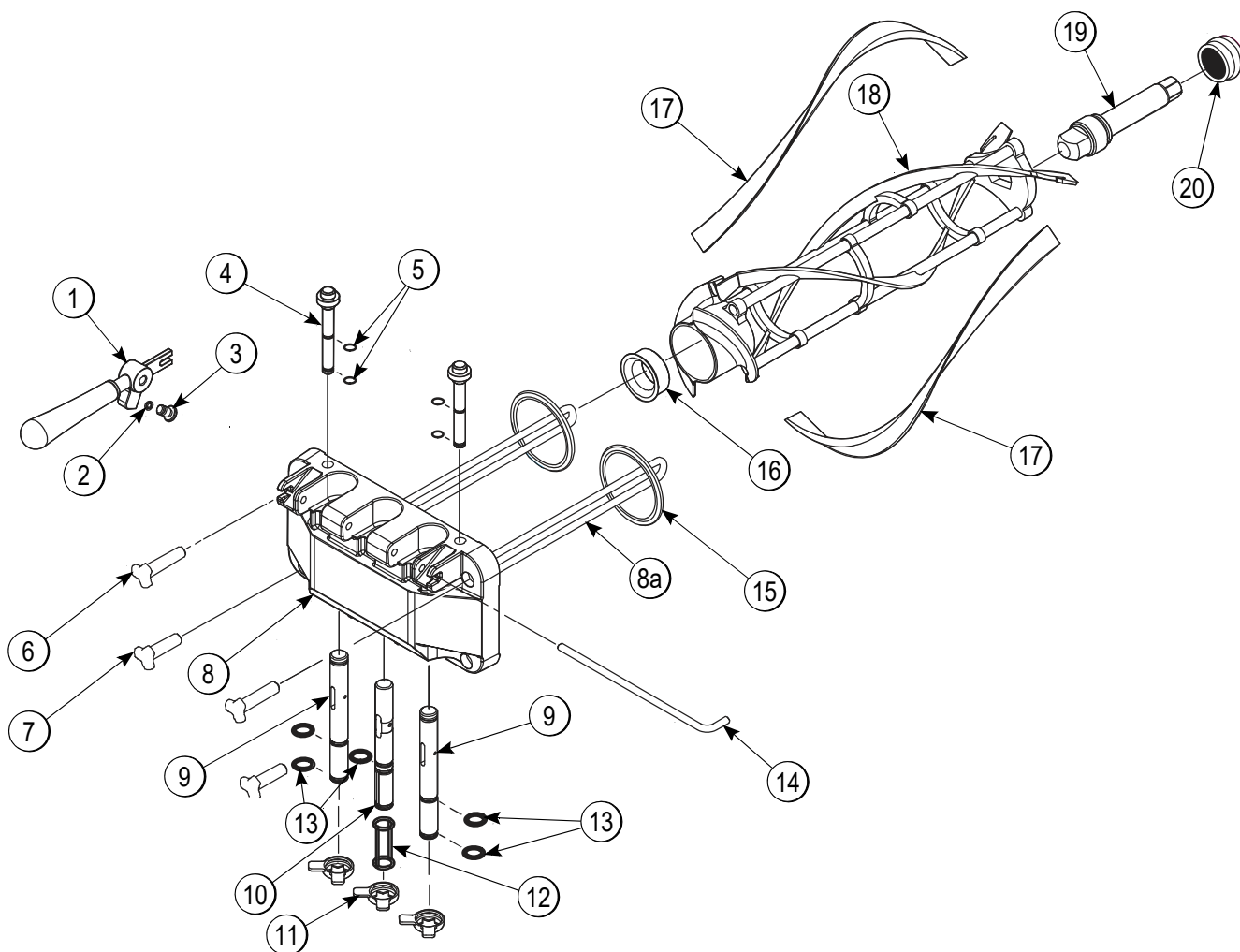
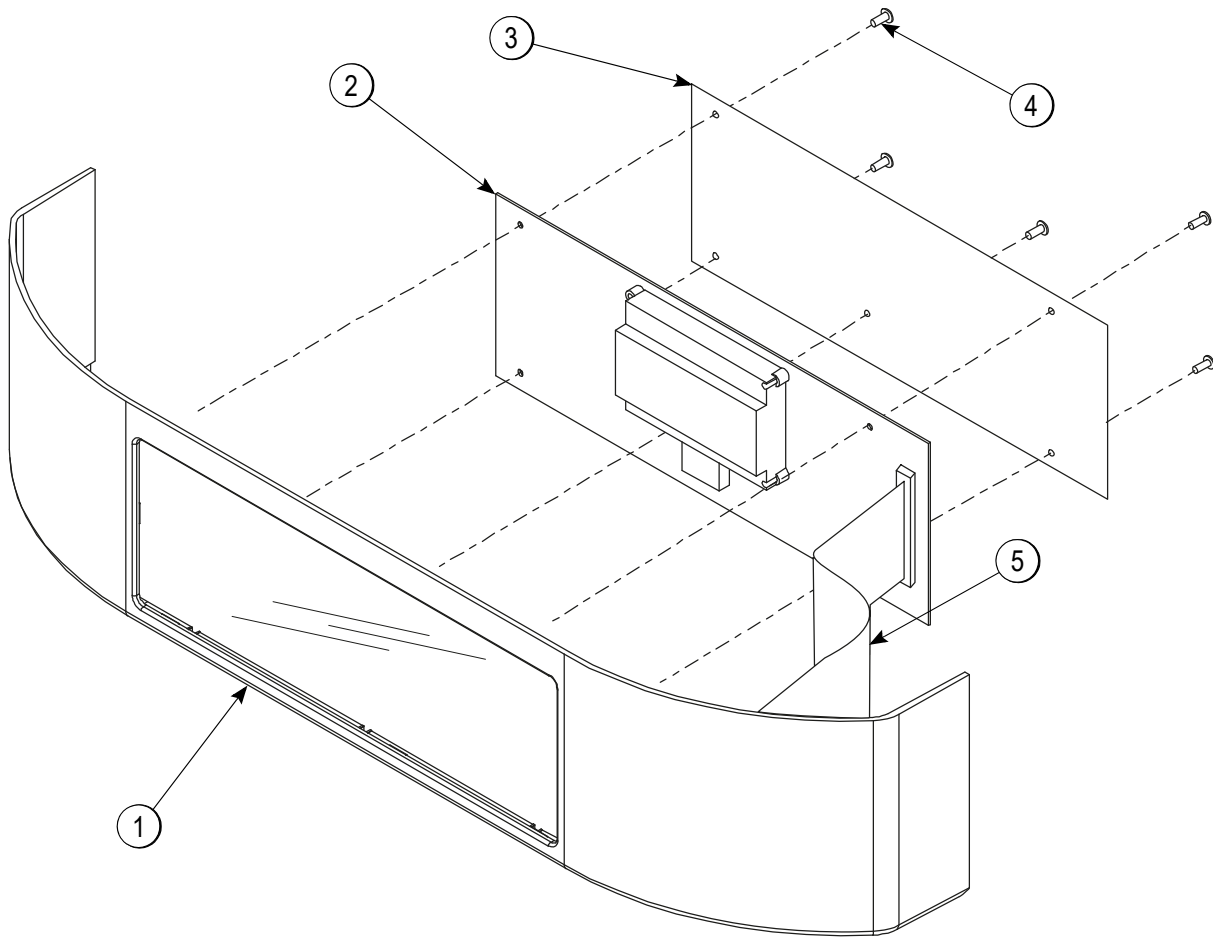

Figure 4-11

Item	Description	Part No.
1	Handle A.-Draw-Welded	X56421-1
2	O-ring-1/4 OD x .070W 50 Duro (25 to Bag)	015872
3	Screw-Adjustment-5/16-24	056332
4	Plug-Prime Twin	059936
5	O-ring-1/2 OD x 0.70 W (50 to Bag)	024278
6	Nut-Stud-Black 3.250 Long	058765
7	Nut-Stud-Black 2.563 Long	058764
8	Door A.-3SPT*LG BAF*W/PRG	X59921-SER
8a	Baffle A.-Long 4 IN w/Rad	X50882
9	Valve A.-Draw	X69615

Item	Description	Part No.
10	Valve A.-Draw Center	X62218
11	Cap-Design 1.010" ID - 6 PNT	014218
12	Seal-Draw Valve	034698
13	O-ring-7/8 OD x .103W-SIL	083693
14	Pin-Handle-Twin	059894
15	Gasket-Door HT 4"-Double	048926
16	Bearing-Front	050216
17	Blade-Scraper-Plastic	035174
18	Beater A.-3.4QT-Helicore	X31761
19	Shaft-Beater	032564
20	Seal-Drive Shaft	032560

# Plate A.-Dec (Model C712)



4

Figure 4-12

Item	Description	Part No.
1	Plate-Dec *Syrup Rail	062121
2	Control-ROHS-INTF	063925-SER
3	Insulator-PCB-Interface	057168

Item	Description	Part No.
4	Screw-6-32X3/8 BIN.HD Slot	002201
5	Cable-Ribbon-14C-3"L	056864

## Plate A.-Dec (Model C713)

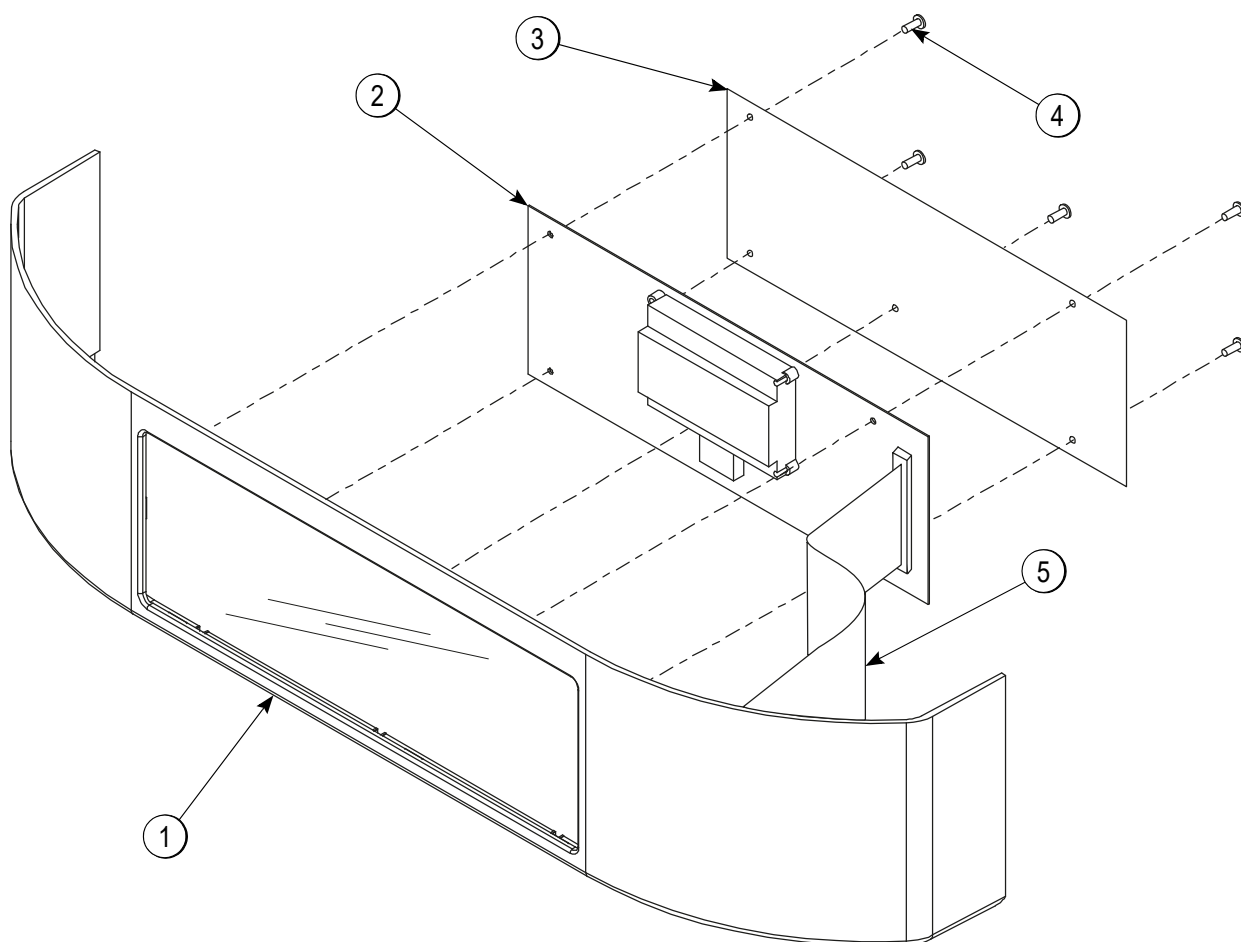

Figure 4-13

Item	Description	Part No.
1	Plate-DEC *Syrup Rail	062122
2	Control-ROHS-INTF	063925-SER
3	Insulator-PCB-Interface	057168

Item	Description	Part No.
4	Screw-6-32x3/8 BIN.HD Slot	002201
5	Cable-Ribbon-14C-3"L	056864

4

# Rail-Syrup - X63883-27 (Optional)

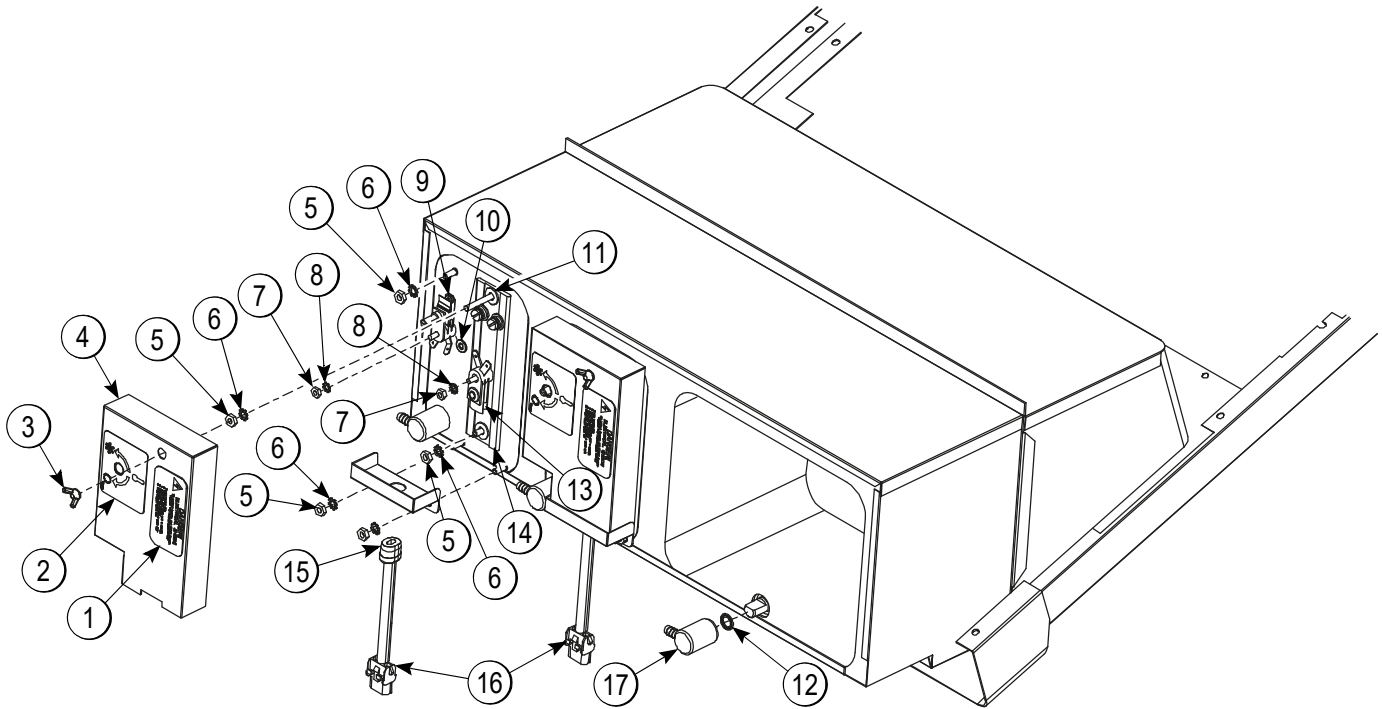

Figure 4-14

Item	Description	Part No.
	Tank A.-Syrup-Heated (Includes:)	X63882-27
1	Label-INST-Syrup Label Reset	055810
2	Label-Adj Temp-Symbol	030994
3	Nut-Wing 10-32 Nylon	034534
4	Box-Heater	043954
5	Nut-10-32 Hex	005598
6	Washer-#10 Ext Tooth Loc	002681
7	Nut-8-32 Hex M/S Nut Small	000969
8	Washer-#8 Ext Tooth Lock	000964

Item	Description	Part No.
9	Thermostat-Adj-Snap	049993
10	Washer-Flat .203 x .437 x .0	080963
11	Washer-3/16 USS Flat 18-8	005194
12	O-ring-9/16 OD x .103W	016369
13	Thermostat-HI Limit-Snap	049992
14	Heater-Strip-175W-240V	042782
15	Relief-Strain-.560X.730-Blk	023764
16	Harness-Wire-SYR-Heaters	068342-27
17	Plug-Drain-Wyott	023953-5

## Switch A.-Dual Lever - X69838 (Model C712 & C713)

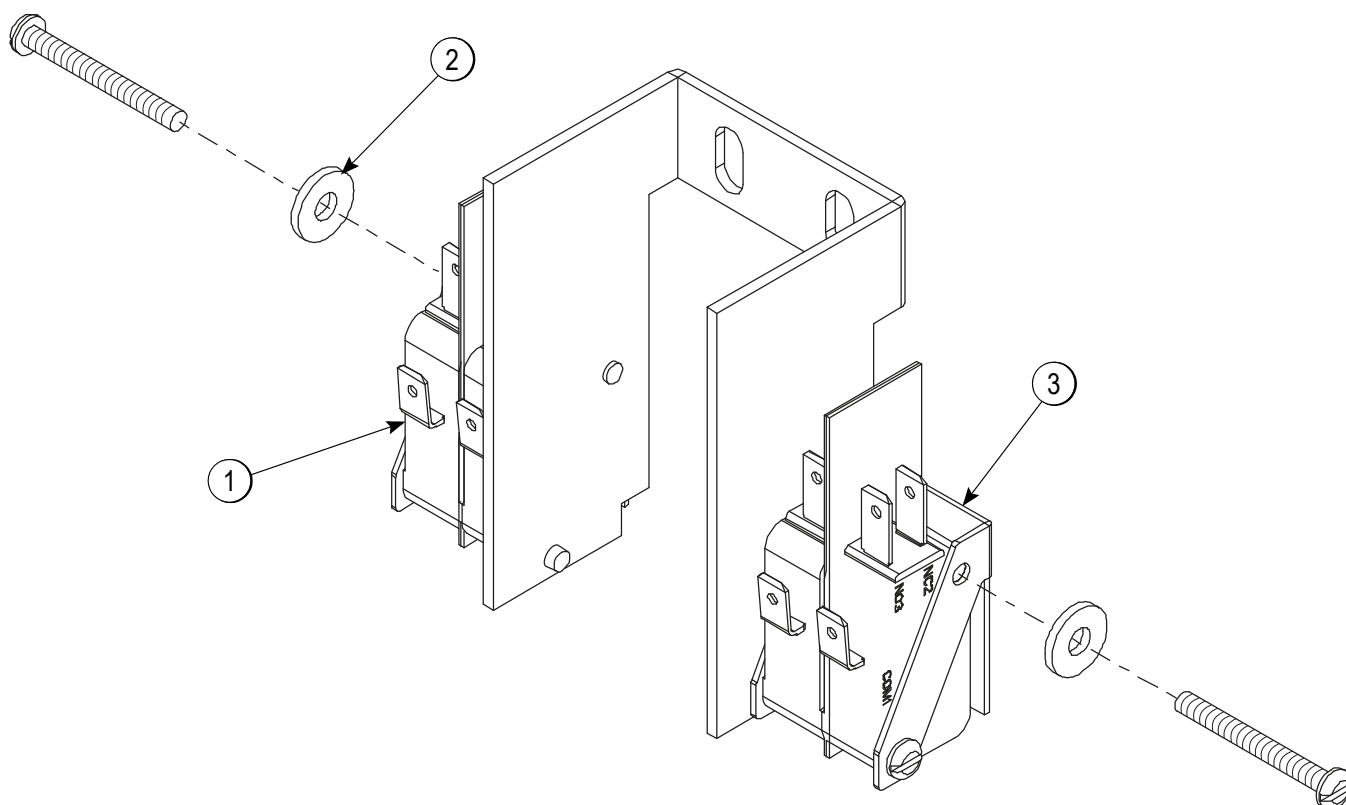

Figure 4-15

Item	Description	Part No.
1	Switch-Lever-SPDT-10A-125	028889
2	Washer-#6 SAE Flat 18-8 SS	023546

Item	Description	Part No.
3	Actuator-Tandem Leaf	062408

# Actuator A.-Draw Switch - X69835 (Model C712 & C713)

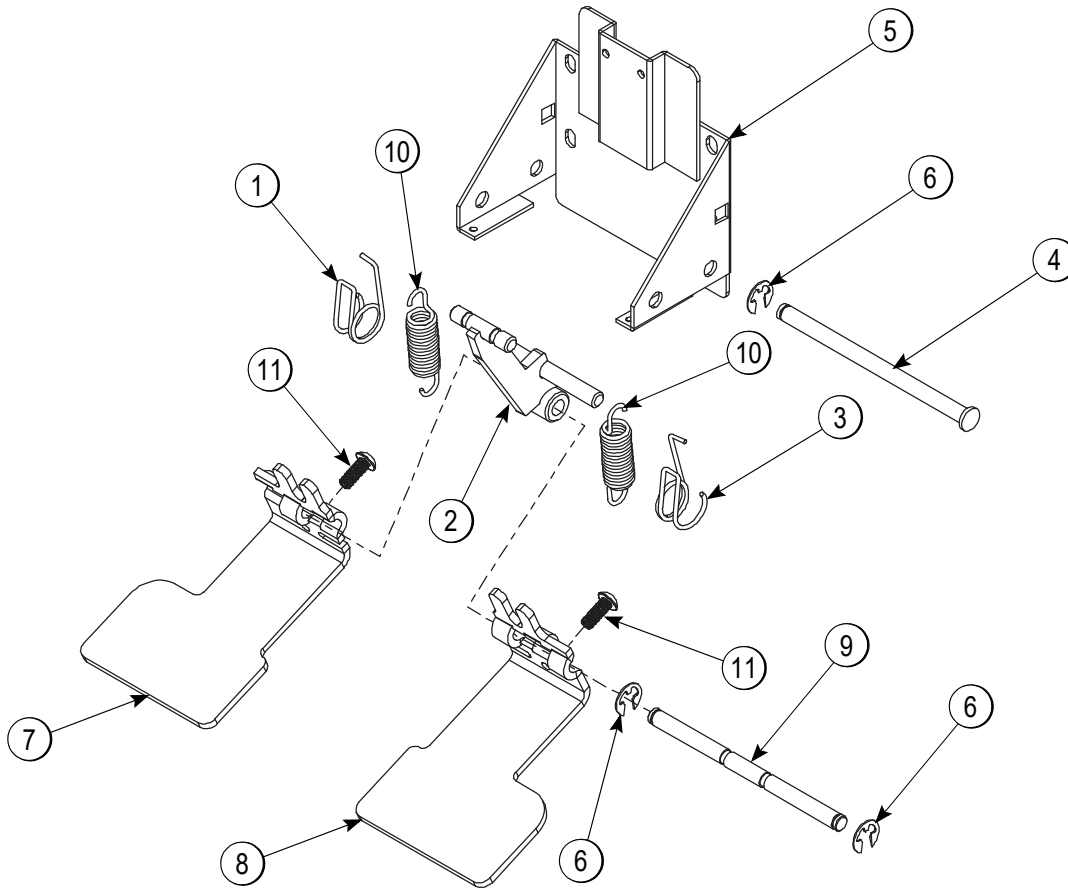

Figure 4-16

Item	Description	Part No.
1	Spring-Return-Left	038923
2	Bracket A.-Spring-Return	X69481
3	Spring-Return-Right	038924
4	Pin-Pivot-Draw Switch	038484
5	Bracket A.-Switch	X69836
6	E-ring 1/4 Black PHOS	032190

Item	Description	Part No.
7	Arm-Draw Switch-Left	069166
8	Arm-Draw Switch-Right	069167
9	Rod-Spring Retainer	038254-SP
10	Spring-Extension.467x.062	069392
11	Screw-Adjustment	069374

## Blower A. X53725-27 (Model C712 & C713)

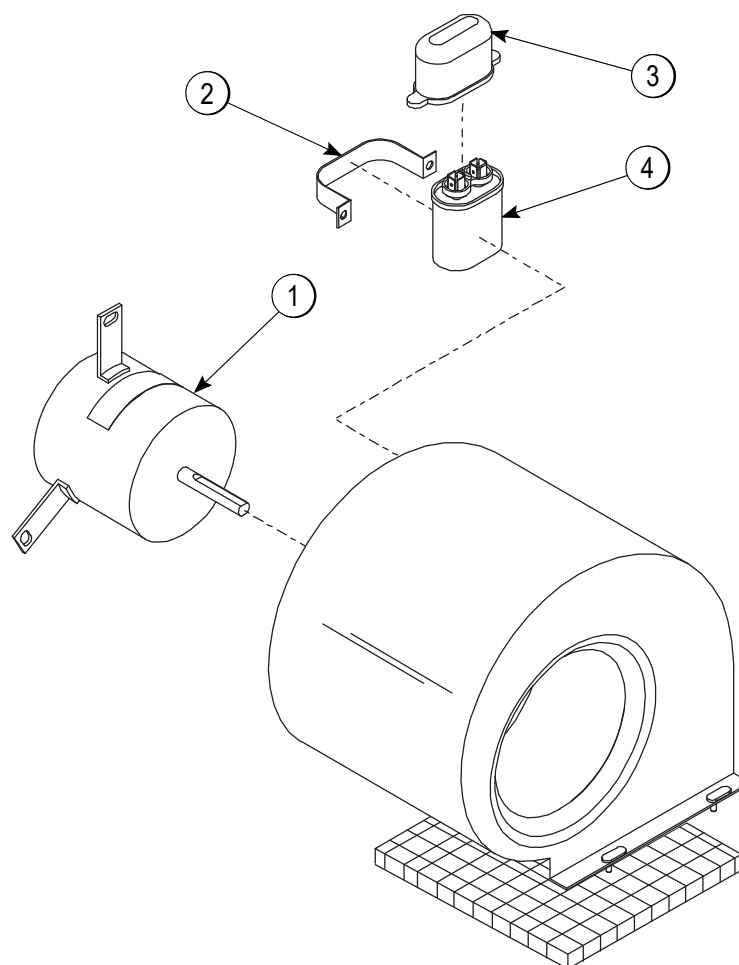
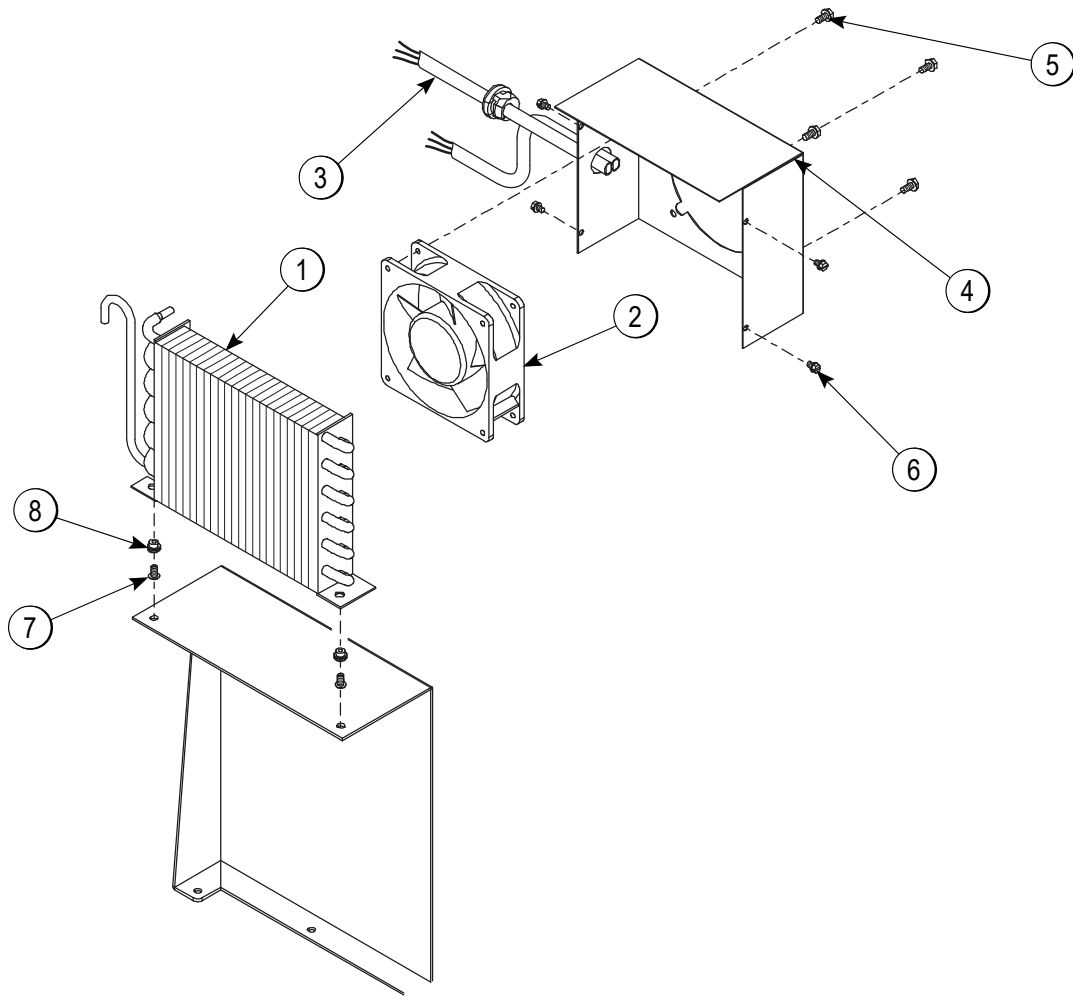

Figure 4-17

Item	Description	Part No.
1	Motor-Fan 208-230V 50/60 HZ	053481-27
2	Bracket-Capacitor 1-1/4X2-1/16	031205

Item	Description	Part No.
3	Boot-Capacitorinsulating	031314
4	Capacitor-Run 7.5UF/370V	034749

# Condenser A. - X68077-27G (Model C712 & C713)



4

Figure 4-18

Item	Description	Part No.
	Motor A.-Condenser Fan Gnd (Includes Items 1-8)	X68008-27G
1	Condenser-AC 7X6X1.25	027155
2	Kit A.-Motor-Fan	X62253-27
3	Harness-Wire-Danfoss	068006-G

Item	Description	Part No.
4	Shroud-Danfoss	027386
5	Screw-10-32X3/8 UNSL	039381
6	Screw-8X1/4 SLTD Hex	009894
7	Screw-10-32X3/8 Slotted	006749
8	Nutsert-10-32	021106



## Accessories

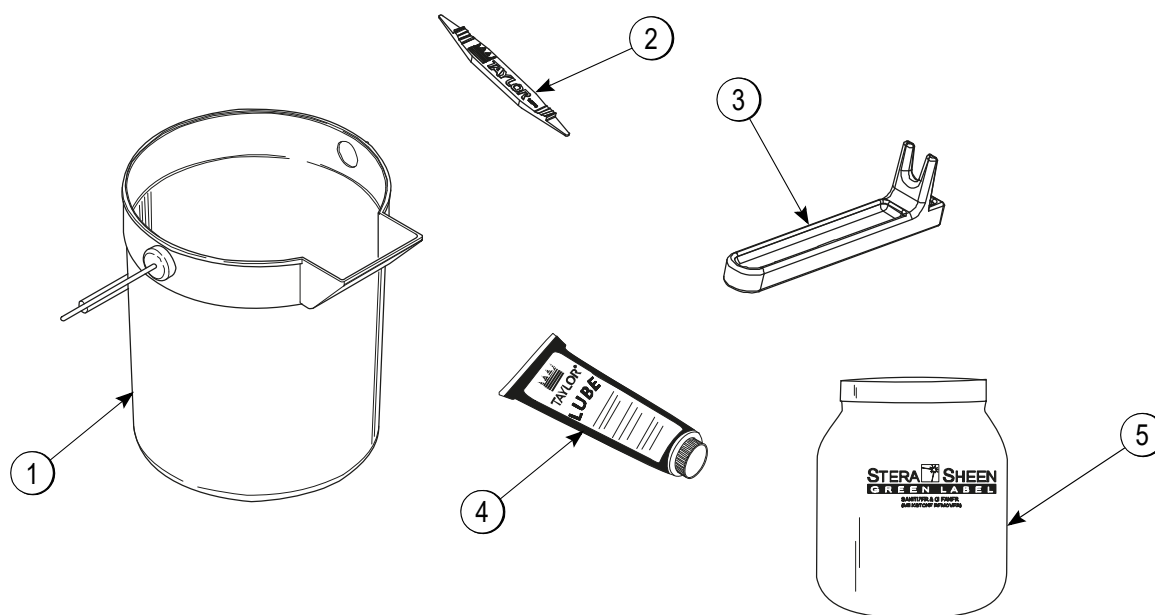

Figure 4-19

4

Item	Description	Part No.
1	Pail-10 QT.	013163
2	Tool-O-ring Removal	048260-WHT
3	Tool-Mix Pump Shaft Removal	057167

Item	Description	Part No.
4	Lubricant-Taylor 4 oz.	047518
*5	Sanitizer-Stera Sheen	SEE NOTE
**	Kit A.-Tune-Up C712	X49463-81

**Note:** A sample container of sanitizer is sent with the machine. For reorders, order Stera-Sheen® part no. 055492 (100 packs) or Kay-5® part no. 041082 (125 packs).

\*\*Not Shown

# Brushes (Model C712 & C713)

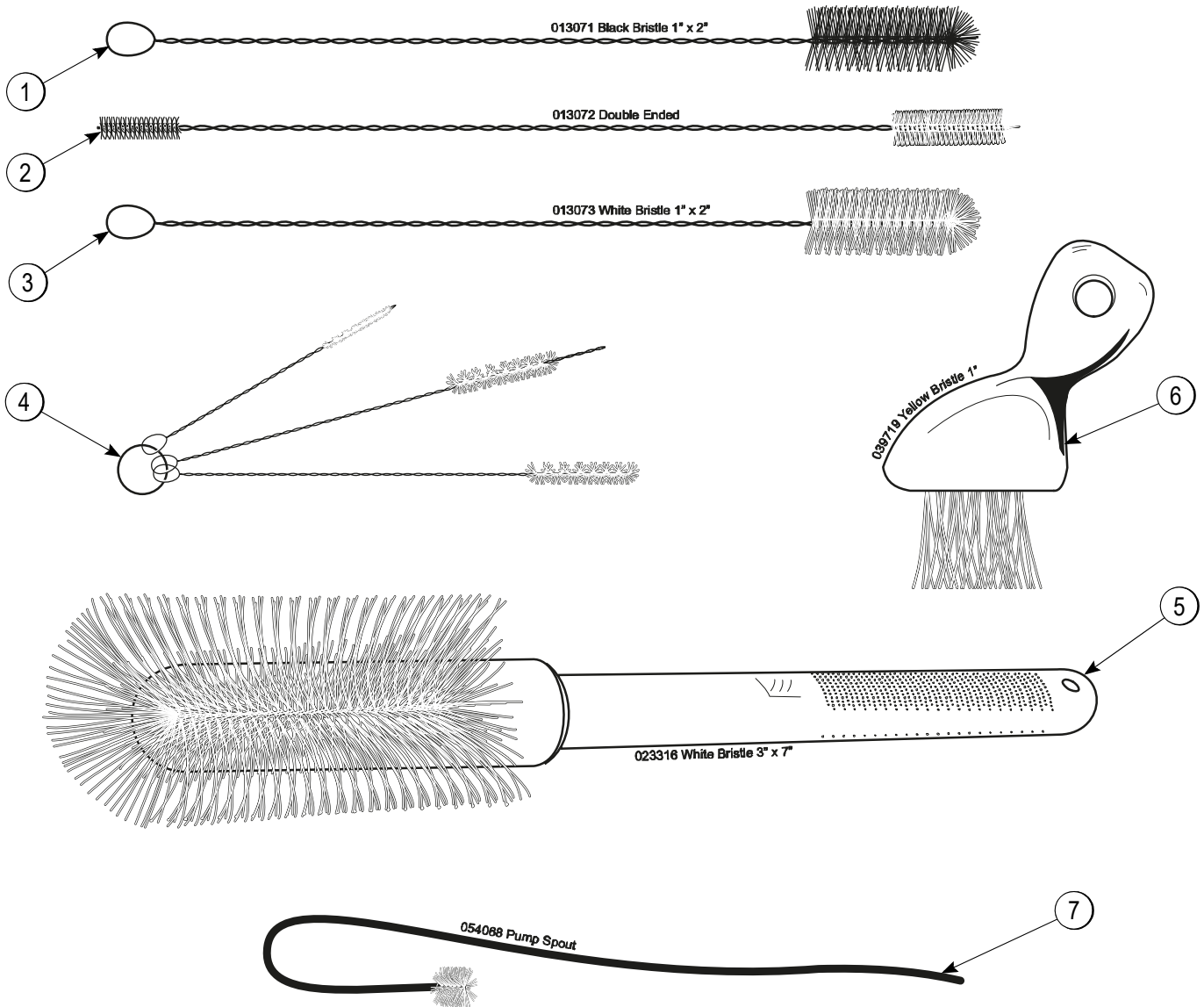

4

Figure 4-20

Item	Description	Part No.
1	Brush-Rear BRG 1"D x 2"LG	013071
2	Brush-Dbl End-Pump & Feed Tube	013072
3	Brush-Draw Valve 1"OD x 2"x1	014753
4	Brush-Mix Pump Body-3" x 7"	023316

Item	Description	Part No.
5	Brush-End-Door-Spout-SS	039719
6	Brush-Set LVB	050103
7	Brush-Pump Spout	054068

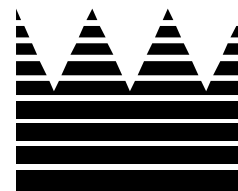

## **Section 5: Parts List**

- **C71227F000 & C71327F000**
- **50HZ/60HZ w/High V - 50HZ**

## + C71227F000 &amp; C71327F000

Description	Part Number	C712 Qty.	C713 Qty.	Warr. Class	Remarks
Actuator A.-Draw Switch *C71X*	X69835	1	1	103	M0114575 and up
Arm-Draw Switch-Left	069166	1	1	103	
Arm-Draw Switch-Right	069167	1	1	103	
Bracket A.-Spring-Return	X69481	1	1	103	
E-Ring 1/4 Black PHOS	032190	3	3	000	
Pin-Pivot-Draw Switch	038484	1	1	103	
Rod-Spring Retainer	038254-SP	1	1	103	
Screw-Adjustment-Draw Paddle	069374	2	2	000	
Spring-Extension.467x.062x1.	069392	2	2	103	
Spring-Return-Left-Twin TWIS	038923	1	1	103	
Spring-Return-Right-Twin TWI	038924	1	1	103	
Actuator A.-Draw Switch	X62401	1	1	103	
Arm-Switch-Draw-l	038649	1	1	103	
Arm-Switch-Draw-r	038650	1	1	103	
Bracket A.-Spring Return	X38257	1	1	103	
E-ring 1/4	032190	4	4	000	
Pin-Pivot-Draw Switch	038484	1	1	103	
Rod-Spring Retainer	038254	1	1	103	
Spring-Extension.500X.054X1.	067352	2	2	103	
Spring-Return-Left-Twin Twist	038923	1	1	103	
Spring-Return-Right-Twin Twist	038924	1	1	103	
Bearing-Rear Shell-Nickel	031324	2	2	000	
+Nut-Brass Bearing	028991	2	2	000	
+Guide-Drip Seal	028992	2	2	000	

5-2

+ Available Separately

Models C712/C713

Parts List

Description	Part Number	C712 Qty.	C713 Qty.	Warr. Class	Remarks
+Washer-Bearing Lock	012864	2	2	000	
Beater A.-3.4QT-1 Pin-Support	X46231	2		103	
+Blade-Scraper-Plastic 8-1/8L	084350	4		000	7/1/16: Replaces 046235 Blade and 0046236 Clip
Beater A.-3.4QT-Helicore	X31761		2	103	
Blade-Scraper-Plastic 17L	035174		4	000	
Belt-AX32	032769	4		000	
Belt-AX30	052191		4	000	
Block-Terminal 2P L1,L2	039422	2	2	103	208-230V 60HZ 1PH
Block-Terminal 1P	073423	2	2	103	208-230V 60HZ 3PH - 3 Wire
Blower A.	X53725-27	1	1	103	
Capacitor-Run 7.5UF/370V	034749	1	1	103	
Boot-Capacitor-Insulating	031314	1	1	000	
Motor-Fan 208-230V 50/60 HZ	053481-27	1	1	103	
Boot-Valve-Expansion	050900	2	2	000	
Brush-Dbf End-Pump & Feed Tube	013072	1	1	000	
Brush-Draw Valve 1"OD X 2"X17"	013073	1	1	000	
Brush-End-Door-Spout-SS-HT	039719	1	1	000	
Brush-Mix Pump Body-3" X 7" WH	023316	1	1	000	
Brush-Pump Spout *MC13*	054068	1	1	000	
Brush-Rear BRG 1"D X 2"LG X 14	013071	1	1	000	
Brush-Set LVB	050103	1	1	000	
Cable-Control/Interface	069023	1	1	103	M1064236 and up UVC4-replaced 056785
Cable-USB	056785	1	1	103	M1064235 and prior - UVC3
Cable-Ribbon-50C-25"L-DIL/DIL	040040-025	1	1	103	
Cable-Ribbon-20C-14"L-DIL/DIL	040040-040	1	1	103	

Description	Part Number	C712 Qty.	C713 Qty.	Warr. Class	Remarks
Cable-Ribbon-20C-16"L-DIL/DIL	040040-049	1	1	103	
Cable-Ribbon-50C-10"L-DIL/DIL	040040-058	1	1	103	
Cable-Ribbon-14C-3"L-SIL/SIL	056864	1	1	103	
Cap-Design 1.010"ID-6 Point	014218	3	3	000	
Cap-Valve Body SS	056874-12	2		103	
Cap-Valve Body SS	056874-14	2		103	
Cap-Valve Body SS	056874-16	2		103	
Caster-4" SWV 3/4-10 STM	044106	2	2	103	
Caster-4" SWV 3/4-10 STM w/Brk	046437	2	2	103	
Clip-Retainer-Mix Pump	044641	2		103	
Compressor L64A113BBCA	048259-27E	2	2	512	Bristol-208-230V 60HZ 1PH - M706 and up
+Capacitor-Run 25UF/440V	037431	2	2	103	
+Capacitor-Start 189-227UF/33	033044-1	2	2	103	
+Relay-Start-Compressor	062363	2	2	103	
Compressor L63A113DBLA	048259-33	2	2	512	Bristol-208-230V 60HZ 3PH
Compressor TL3G-R134A	047701-27	1	1	512	
+Relay-Start-Compressor-TL3G	047702-27	1	1	103	
+Capacitor-Start 60UF-220/275V	047703	1	1	103	
+Kit-Mounting-Compressor	047704	1	1	000	
Condenser-AC 7X6X1.25-2 ROW	027155	1	1	103	
Condenser-AC 12LX18HX3.12T-5RW	055813-1	1	1	103	
Condenser-AC 12LX18HX3.12T-5RW	055813-2	1	1	103	
+Label-Warn-Condenser-Sharp	059287	3	3	000	
Control-ROHS-INTF*C712-C717*	063925-SER	1	1	212	Dec Plate - replaces X59435-SER
Control-INTERF-HT-SS-C712-ROHS	063967-SER	2	2	212	Replaces X63967-SER

5-4

+ Available Separately

Models C712/C713

Parts List

Description	Part Number	C712 Qty.	C713 Qty.	Warr. Class	Remarks
PCB A.-ROHS-Personality-HT-SS	063922-SER	2	2	212	
Control-ROHS-INTF-Hotgas*C602*	063926-SER	2	2	212	Replaces X63926-SER
Core-Schrader Valve-Teflon	037047	4	4	103	
Coupling-Drive 3/4 Hex X 1-7/8	012721	2	2	103	
Cover-Hopper *Black*	053809SER1	2	2	103	N/A See Kit A.-Cover-Hopper X67061-SP
Decal-Door-3 Spout-Twin Twist	062239	1	1	000	
Decal-INST-CLN-PMP HPR	042170	1		000	
Decal-INST-CLN HPR	019029		1	000	
Decal-Troubleshoot	038374	1	1	000	
Deflector-Blower Exhaust	047912	1	1	103	
Diagram-Wiring *C712*	059898-27	1		000	208-230V 60HZ 1PH
Diagram-Wiring *C712*	059898-33	1		000	208-230V 60HZ 3PH - 3 Wire
Diagram-Wiring *C713*	059899-27		1	000	
Diagram-Wiring *C713*	059899-33		1	000	
Door A.-3SPT*LG BAF*W/PRG*C712	X59921-SER	1	2	103	
Baffle A.-Long 4 IN W/RAD THD	X50882	2	4	103	
+ Bearing-Front-Shoe Kit	X50350	2		000	
+ Bearing-Front	050216		4	000	
+ Decal-Door-3 Spout-Twin Twist	062239	1	2	000	
+ Gasket-Door-4"-Dart	048926	2	4	000	
+ Handle A.-Draw *C602*	X56421-1	3	6	103	
+ Screw-Adjustment-5/16-24 *602*	056332	3	6	103	
+ O-ring-1/4 OD X .070W 50 Duro	015872	3	6	000	
+ Pin-Handle-Twin *C712/C717*	059894	1	2	103	
+ Plug-Prime Twin *C712/C713*	059936	2	4	103	

Description	Part Number	C712 Qty.	C713 Qty.	Warr. Class	Remarks
+O-ring-1/2OD X .070W	024278	4	8	000	
+Valve A.-Draw *C712/C713*	X69615	2	4	103	S/N M5056886 and up - replaced X59843
+O-ring-7/8 OD X .103W-SIL	083693	5	10	000	S/N M5056886 and up - replaced 014402
+Valve A.-Draw-Center	X62218	1	2	103	
+O-ring-7/8 OD X .103W-SIL	083693	1	2	000	S/N M5056886 and up - replaced 014402
+Seal-Draw Valve	034698	1		000	
Dryer-Cap. Tube .026ID X 13FT	047699	1	1	000	
Dryer-Filter-HP6-3/8 X 1/4S	048901	2	2	000	
Eyelet-Reset Button	013739	6	4	103	
Fastener-Clip 1/4-20 U-Type	045865	12	12	000	
Fastener-Door Latch	030787	2	2	000	
Fastener-Door Strike	030788	2	2	000	
Filter-Corcom 6EH1	040140-001	1	1	103	
Filter-Air-Poly-Flo	052779-11	2	2	000	
Gear A.*Reducer 4.21:1	021286-SER	2	2	212	
Guard-Power Switch	034830	1	1	103	
Guide A.-Drip Pan-Center	X59913	1	1	103	
Guide A.-Drip Pan-Left	X59910	1	1	103	
Guide A.-Drip Pan-Right	X59911	1	1	103	
Harness-Wire*C712-C717*CR	06543627SP	1	1	103	208-230V 60HZ 1PH
Harness-Wire *C712-C717*C	065436-33	1	1	103	208-230V 60HZ 3PH - 3 Wire
Harness-LIQ SOL Valve *C712*	063370	2	2	103	
Harness-Wire-Beater MTR*C71*	066440-27G	2	2	103	208-230V 60HZ 1PH
Harness-Wire-Beater MTR*C71*	066440-33G	2	2	103	208-230V 60HZ 3PH - 3 Wire
Harness-Wire-Blower C712/C713	066438	1	1	103	

5-6 + Available Separately

Models C712/C713

Parts List



+ Available Separately		Description	Part Number	C712 Qty.	C713 Qty.	Warr. Class	Remarks
		Harness-Wire-Compressor*C71*	066436-33G	2	2	103	208-230V 60HZ 3PH - 3 Wire
		Harness-Wire-Control Box*C712*	068007	1	1	103	
		Harness-Wire-LW V-MIX LVL-C7	063489	1	1	103	
		Harness-Wire-Mix Pump*C71*	066437	2		103	
		Harness-Wire-Power Switch	062051	1	1	103	
		Hinge A.-Motor *632-8756* ALT	X25736	2	2	103	
		Jack A.-Flavorburst *C706*	X56353	2	2	103	
		Kit A.-Beater-Front Shoes	X50350	2		000	
		Kit A.-Cover-Hopper*Dual*BLK	X67061-SP	1	1	103	
		Kit A.-Motor-Fan	X62253-27	1	1	103	Replaces 062253-27
		Kit A.-Probe-Thermistor IP68	X82397-SER	4	4	103	Replaces 038061-BLK
		Kit A.-Tune C712 SIMPL Pump	X49463-81	1		000	
		Gasket-Door HT 4"-Double	048926	2		000	
		Kit A.-Beater Front Shoes	X50350	2		000	
		Kit A.-Draw Valve C712	X56200-17	1		000	
		Cap-Design 1.010"ID-6 Point	014218	3		000	
		O-ring-7/8 OD X .103W-SIL	083693	5		000	S/N M1103791 and up - replaced 014402 and 019330
		O-ring-1/2OD X .070W	024278	4		000	
		Seal-Draw Valve	034698	1		000	
		Kit A.-Pump-Simplified SS/SH	X56200-10	2		000	
		O-ring-1-3/4 OD X .139W	008904	2		000	
		O-ring-11/16ODX.103W-RED	016132	4		000	
		O-ring-2-1/8 OD X .139W-#225	020051	4		000	
		O-ring 1/2 ID X .139W	048632	4		000	
		Gasket-Simplified Pump Valve	053527	2		000	

Description	Part Number	C712 Qty.	C713 Qty.	Warr. Class	Remarks
Ring-Check-Feed-Tube	056524	2		000	
Seal-Drive Shaft	032560	2		000	
Tool-O-ring Removal-Freezer	048260-WHT	1		000	
Kit A.-Tune Up-3 SPT C713	X49463-80		1	000	
Bearing-Front	050216		2	000	
Cap-Design 1.010"ID-6 Point	014218		3	000	
Gasket-Door HT 4"-Double	048926		2	000	
O-ring-.643 OD X .077W	018572		8	000	
O-ring-1/2OD X .070W	024278		4	000	
O-ring-3/8 OD X .070W	016137		2	000	
O-ring-7/8 OD X .103W-SIL	083693		5	000	S/N M1103791 and up - replaced 014402 and 019330
Seal-Draw Valve	034698		1	000	
Seal-Drive Shaft	032560		2	000	
Tool-O-ring Removal-Freezer	048260-WHT		1	000	
Kit-Mounting-Compressor	047704	1	1	000	
Label-3PH MTR PROT/1PH C-	025949	1	1	000	208-230V 60HZ 3PH - 3 Wire
Label-CK MTR Rotate-CW-ENG/SPN	020090	1	1	000	208-230V 60HZ 3PH - 3 Wire
Label-Caution-BTR STRT G3	039897	1	1	000	
Label-Caution-GRD-PERM-ENG/SP	032164	1	1	000	
Label-Door-Move Part	032749	1	1	000	
Label-SW-Power-Off/On-Symbols	052632	1	1	000	
Label-Warn-Elec-SGL-Small	032717	1	1	000	
Label-Warn-Condenser-Sharp	059287	3	3	000	
Label-Warn-Cover	051433	4	4	000	
Label-Warn-Elec-TW-Small	032718	1	1	000	

5-8 + Available Separately

Models C712/C713

Parts List

+ Available Separately

Description	Part Number	C712 Qty.	C713 Qty.	Warr. Class	Remarks
Label-Wiring Single Phase	052396-1	1		000	208-230V 60HZ 1PH
Lubricant-Taylor 4 oz.	047518	1	1	000	
Man-Oper C712	062179-M	1		000	
Man-Oper C713	062180-M		1	000	
Motor-1.5 HP Caps@10&2 O'clock	021522-27	2	2	212	208-230V 60HZ 1PH
Motor-1.5 HP	021522-33	2	2	212	208-230V 60HZ 3PH - 3 Wire
+label-CK MTR Rotate-CW-ENG/SPN	020090	1	1	000	
Motor-Fan 95.3 CFM 2700 RPM	062253-27	*	*	103	N/A See X62253-27 Kit A.-Motor-Fan Condensr
Motor-Fan 208-230V 50/60 HZ	053481-27	1	1	103	
Motor-Reducer-Service	036955-34S	2		212	
Nut-Stud-Black 2.563 Long	058764	2	2	103	
Nut-Stud-Black 3.250 Long	058765	2	2	103	
Orifice	022465-100	2	2	103	
+O-ring-3/8 OD X .070W	016137	2	2	000	
Overload-Thermal-Remote PMP SS	067965	2		103	
+Clip-Retainer-Overload-PMP MTR	068038	2		000	
Pail-Mix 10 QT.	013163	1	1	000	
Pan-Drip 7.875	059737	2		103	
Pan-Drip 12.5	059736	2	2	103	
Pan-Drip 19-1/2 Long	035034	1	1	103	
Panel A.-Filter-Louvered	X59928	2	2	103	
Panel A.-Front *C712/C716*	X63879	1	1	103	
Panel A.-Front *C712-C717*	X59836	1	1	103	
Panel A.-Front Lower	X59854-SER	1	1	103	
Panel-Corner-FRNT-R *C712/C717	063087	1	1	103	

Description	Part Number	C712 Qty.	C713 Qty.	Warr. Class	Remarks
Panel-Corner-FRNT-L*C712/C717*	063088	1	1	103	
Panel-Rear *C712/C716*	064258-SER	1	1	103	
Panel-Side-Left *C712/C717*	059906	1	1	103	
Panel-Side-Right *C712/C717*	059907	1	1	103	
PCB A.-Control *C712* UVC4	X69355-SER	1	1	212	C712 - S/N M3067204 and up
Control-UVC4	X68114-SER	1	1	212	
PCB A.-Control *C712* UVC4	X69355SER1	**	**		Use to update from UVC3 to UVC4
Pin-Cotter-Hairpin-1/8DIA	044731	2		103	
Pin-Retaining-Hopper Cover	043934	2	2	103	
Plate-DEC *C712* Syrup Rail	062121	1		103	
Plate-DEC *C713* Syrup Rail	062122		1	103	
Probe A.-Mix	X56912	2	2	103	Mix Low
+Spacer-Probe-Mix-Upper *C708	056910	2	2	000	
Probe-Mix Out *C708*	056908	2	2	000	Mix Out
+Spacer-Probe-Mix-Middle *C70	056907	2	2	000	
+Spacer-Mix Probe *C708*	056985	2	2	000	
+Screw-10-32X2-1/4 Slot. Round	057610	2	2	000	
+O-ring-1-3/8 OD X .070W	017395	6	6	000	
+Nut-10-32 Hex Machine Screw	005598	4	4	000	
+Nut-1/4-20 Finished Hex Nut	000707	4	4	000	
Probe-Thermistor-Barrel-2% TOL	038061-BLK	4*	4*	103	NLA - Use X82397-SER
Pulley-2AK22 X .625-.6265	016403	2	2	103	
Pulley-2AK74-5/8	027822	2		103	
Pulley-2AK64-5/8 Bore	039695		2	103	
Pump A.-Mix Simplified S.S.	X57029-14	2		103	

5-10

+ Available Separately

Models C712/C713

Parts List

Description	Part Number	C712 Qty.	C713 Qty.	Warr. Class	Remarks
Adaptor-Mix Inlet-SS-Red	054825	2		103	
Cap-Valve Body SS	056874-14	2		103	
Cylinder-Pump Hopper Softserve	057943	2		103	
Gasket-Simplified Pump Valve	053527	2		000	
O-ring-2-1/8 OD X .139W-#225	020051	4		000	
Pin A.-Retaining	X55450	2		103	
Piston-Pump-Simplified	053526	2		103	
+Clip-Retainer-Mix Pump	044641	2		103	
Relay-3 Pole-20A-208/240 50/60	066795-33	2	2	103	
Relay-DPDT 100UA TO 7A 1/8HP	052111-03	2	2	103	
+Socket-Relay-for US W/052111	052112	2	2	103	
Relay-MTR Start TI#4CR-1-625	039725-27	2		103	
Relay-Start-Compressor-TL3G	047702-27	1	1	103	
Relay-Start-Compressor	062363	2	2	103	
Sanitizer-Stera Sheen -Green	055492	1	1	000	
Screw-10-24X1/2 Taptite-Torx	002077	4	4	000	
Screw-6-32X3/8 BIN.HD Slot SS	002201	2	2	000	
Screw-5/16-18X2-1/2 Hex Cap	002498	8	8	000	
Screw-10-32X3/8 RHM-ZP	002742	8	8	000	
Screw-1/4-20X3/8 RHM-STNLS	011694	14	14	000	
Screw-1/4-20X3/4 SOC HD Cap	020128-2	6		000	
Screw-8X3/8 RD HD TYP B	013234	2	2	000	
Screw-5/16-18X3-1/4STL Hexcap	022678	4		000	
Screw-5/16-18X2-3/4 Hex Cap	004191	8		000	
Shaft A.-Drive-Mix Pump-Hopper	X41947	2		103	

+ Available Separately

Models C712/C713

Description	Part Number	C712 Qty.	C713 Qty.	Warr. Class	Remarks
Crank-Drive-Hopper Mix Pump	039235	2		103	
O-ring 1/2 ID X .139W	048632	4		000	
O-Ring-1-3/4 OD X .139W	008904	2		000	
Shaft-Drive-Mix Pump-Hopper	041948	2		103	
+Seal-Drive Shaft	032560	2		000	
Shaft-Beater	032564	2	2	103	
+Seal-Drive Shaft	032560	2	2	000	
Shelf-Tray-Drip*712-13*716-17	063877	1	1	103	
+Tray-Drip-19-5/8 L X 4-7/8	033812	1	1	103	
Shell A.-Insulated *C712*	X63324-SER	1		512	
+Stud-Nose Cone *C602*	055987	4		103	
Shell A.-Insulated	X63337-SER		1	512	
+Stud-Nose Cone *C602*	055987		4	103	
Shield-Splash-Wire-19-3/4 L	033813	1	1	103	
Shoe-Front Helix Use X50350 Kit		*		000	
Spring-Comp.970X.115X2.00	025707	4	4	103	
Starter-1 Phase 6.3 to 10 AMP	066794-27K	2	2	103	208-230V 60HZ 1PH
Overload-Thermal-1P-6.3/10A	067461-1K	2	2	103	208-230V 60HZ 1PH
Starter-3 Phase 4 to 6.5 AMP	066794-33J	2	2	103	208-230V 60HZ 3PH - 3 Wire
Overload-Thermal-3P-4.0/6.5A	067461-3J	2	2	103	208-230V 60HZ 3PH - 3 Wire
Draw Switch					See - Actuator A.-Draw Switch
Switch A.-Dual Lever *C71X*	X69838	1	1	103	S/N M1104575 and up previously X62400
Switch-Lever-SPDT-10A-125-25	028889	4	4	103	
Actuator-Tandem Leaf	062408	2	2	103	
Insulator-Switch 1/64 Armité	029099	4	4	000	Added S/N M4033841 and up

Description	Part Number	C712 Qty.	C713 Qty.	Warr. Class	Remarks
Washer-#6 Sae Flat 18-8 SS	023546	2	2	000	
Screw-4-40X1 PHIL. Pan Taptite	045141	2	2	000	
Switch-Pressure 440 PSI-Solder	048230	2	2	103	
Switch-Reed*Door Interlock*68"	056771	1	1	103	
Tool-O-ring Removal-Freezer	048260-WHT	1	1	000	
Tool-Mix Pump Shaft Removal	057167	1		000	
Trans.-Cont.-32VA 120/200/240V	054834	1	1	103	
Trans.-120/208/240V PRI 24VSEC	051660	1	1	103	
Tray-Drip-19-5/8 L X 4-7/8	033812	1	1	103	
+Shelf-Tray-Drip*712-13*716-1	063877	1	1	103	
+Nut-10-32 Nylon Insert Lock	600144	2	2	000	
+Screw-10-32X1/2 SLTD Truss	037734	2	2	000	
Trim-Corner-Rear-L	059896	1	1	103	
Trim-Corner-Rear-R	059897	1	1	103	
Tube A.-Feed-Left *C712/C717*	X59808	1		103	
+O-ring-11/16ODX.103W-Red	016132	4		000	
Tube A.-Feed-Right *C712/C717*	X59809	1		103	
+O-ring-11/16ODX.103W-Red	016132	4		000	
Tube A.-Feed-SS-5/32 Hole DIA	X29429-2	*	2	103	C712 Feed Tube Optional
+O-ring-.643 OD X .077W	018572	*	8	000	
Valve-Access-1/4 MFLX1/4 S-90	047016	1	1	103	
Valve-Access 1/4FL X 1/4SOLDER	044404	1	1	103	
Valve-Access-1/4MFL X 3/8ODSDR	053565	4	4	103	
+Core-Schrader Valve-Teflon	037047	4	4	000	
Valve-EPR 1/4S	022665	1	1	103	

Description	Part Number	C712 Qty.	C713 Qty.	Warr. Class	Remarks
Valve-EXP-Auto-1/4S X1/4 FPT	046365	2	2	103	
+Boot-Valve-Expansion	050900	2	2	000	
Valve-Solenoid 7/64ORF X 1/4S	043449-27	2	2	103	
<b>Water Cooled</b>					
Accumulator-Copper 2"DIA 10"	047062	2	2	103	
Blower-100 CFM	012796-27	1	1	103	
+Guard-Blower	022505	1	1	103	
Condenser-WC-Coax	047540	2	2	103	
Hose-Rubber 1/2 ID X 7/8 OD	R50200	15	15'	000	
+Clamp-Hose 3/4 ID CONST TENSN	067113	8	8	000	
Outlet A.-TEE	X25900	1	1	103	
Panel-Side-L. W/C *C712/C717	062160	1	1	103	
Panel-Side-R. W/C *C712/C717	062161	1	1	103	
Plate-Condenser W/C	062043-SP	1	1	103	
Pipe TEE 3/8-Water Valve-Blk	032953	1	1	103	
Switch-Pressure 350 PSI-SOLD	048231	2	2	103	
Valve-Water 3/8 Reg/Head Press	046686	2	2	103	
<b>50HZ/60HZ w/High V - 50HZ</b> C71235F000 & C71335F000 - 220-240V 50HZ 3PH, C71337R974 - 200V 50HZ 3PH, C71239FW00 & C71339R000 - 200V 50/60HZ 3PH, C71240FW00 & C71340FW00 - 220-240V 50HZ 1PH, C71258FW00 & C71358FW00 - 380-415V 50HZ 3N~ (4WIRE), C71260FW00 & C71360F000 - 220-380V 60HZ 3PH-4 WIRE					
Belt-AX33	024396	4		000	220-240V 50HZ 3PH/C712 220-240V 50HZ 1PH/380-415V 50HZ 3N~(4WIRE)
Belt-AX32	032769	4	4	000	200V 50HZ 3PH/200V 50/60HZ 3PH / 220-380V 60HZ 3PH-4 WIRE
Belt-AX31	041575		4	000	C713 220-240 50HZ 1PH/C713 380-415V 50HZ 3N~(4WIRE)



Description	Part Number	C712 Qty.	C713 Qty.	Warr. Class	Remarks
Block-Terminal 3P L1,L2,L	039423	1		103	220-240V 50HZ 3PH/200V 50/60HZ 3PH/200V 50/60HZ 3PH/220-240V 50HZ 1PH
Block-Terminal 2P L1,N	039421	2	2	103	220-240V 50HZ 1PH
Block-Terminal 4P L1,L2,L	039424	2	2	103	380-415V 50HZ 3N~ (4WIRE)/220-380V 60HZ 3PH-4WIRE
Capacitor A.-RF	X58666-1	2	2	103	220-240V 50HZ 1PH
	048259-33	2		512	220-240V 50HZ 3PH/200V 50/60HZ 3PH
Compressor L63A113BBKA	048259-40	2	2	512	220-240V 50HZ 1PH
+Capacitor-Run 25UF/370VAC	023739	2	2	103	220-240V 50HZ 1PH
+Capacitor-Start 161-193UF	031790	2	2	103	220-240V 50HZ 1PH
+Relay-Start-Compressor	038146	2	2	103	220-240V 50HZ 1PH
Compressor L63A113DBEA	048259-58	2	2	512	380-415V 50HZ 3N~ (4WIRE)/220-380V 60HZ 3PH-4WIRE
Diagram-Wiring *C712*	059898-35	1		000	220-240V 50HZ 3PH
Diagram-Wiring *C712*	059898-39	1		000	200V 50/60HZ 3PH
Diagram-Wiring *C712*	059898-40	1		000	220-240V 50HZ 1PH
Diagram-Wiring *C712*	059898-58	1		000	380-415V 50HZ 3N~ (4WIRE)
Diagram-Wiring *C712*	059898-60	1		000	220/380V 60HZ 3PH-4 WIRE
Diagram-Wiring *C713*	059899-35		1	000	220-240V 50HZ 3PH
Diagram-Wiring *C713*	059899-39		1	000	200V 50HZ 3PH/200V 50/60HZ 3PH
Diagram-Wiring *C713*	059899-40		1	000	220-240V 50HZ 1PH
Diagram-Wiring *C713*	059899-58		1	000	380-415V 50HZ 3N~ (4WIRE)
Diagram-Wiring *C713*	059899-60		1	000	220-380V 60HZ 3PH-4 WIRE
Harness-LIQ SOL VLV-GND *	063370-G	2	2	103	200V 50HZ 3PH/220-240V 50HZ 3PH/200V 50/60H 3PH/ 220-240V 50HZ 1PH/380-415V 50HZ 3~(4WIRE)/220-380V 60HZ 3PH-4WIRE
Harness-Wire *C712-C717*C	065436-33	1		103	220-240V 50HZ 3PH/200V 50/60HZ 3PH

Description	Part Number	C712 Qty.	C713 Qty.	Warr. Class	Remarks
Harness-Wire *C712-C717*C	065436-58	1	1	103	380-415V 50HZ 3N~ (4WIRE)/220-380V 60HZ 3PH-4WIRE
Harness-Wire*C712-C717*CR	06543640SP	1	1	103	220-240V 50HZ 1PH
Harness-Wire-Beater MTR*C71	066440-27G	2	2	103	220-240V 50HZ 1PH
Harness-Wire-Beater MTR*C	066440-33G	2		103	380-415V 50HZ 3N~ (4WIRE)/220-380V 60HZ 3PH-4WIRE
Harness-Wire-Blower C712/	062057	1		103	220-380V 60HZ 3PH-4 WIRE
Harness-Wire-Compressor*C	066436-33G	2		103	220-240V 50HZ 1PH/380-415V 50HZ 1PH/220-380V 60HZ 3PH-4WIRE/220-380V 60HZ 3PH-4WIRE
Harness-Wire-Danfoss *C71	068006-G	1	1	103	200V 50HZ 3PH/220-240V 50HZ 3PH/220-240V 50HZ 1PH/200V 50/60H 3PH/380-415V 50HZ 3N~(4WIRE)
Hinge-Motor-2 HP*C716*	065917	2	2	103	220/380V 60HZ 3PH-4 WIRE
Indicator-Digital Temp-SO	051356	2	2	103	220-240V 50HZ 3PH/220-240V 50HZ 1PH/380-415V 50HZ 3N~(4WIRE)/220-380V 60HZ 3PH(4WIRE)
Motor-1.5 HP	021522-33	2		212	200V 50/60HZ 3PH
Motor-1.5 HP Caps@10&2 O'clock	021522-34	2	2	212	220-240V 50HZ 1PH /220-380V 60HZ 3PH-4WIRE
Motor-1.5 HP	021522-35	2	2	212	220-240V 50HZ 3PH/380-415V 50HZ 3N~(4 WIRE)
Motor-2.0 HP	017650-33	2	2	212	220-380V 60HZ 3PH-4 WIRE
Panel A.-Upper Front C712	X63978	1	1	103	220-240V 50HZ 3PH/200V 50-60HZ 3PH/220-240V 50HZ 1PH/380-415V 50HZ 3N~(4WIRE)/220-380V 60HZ 3PH(4WIRE)/C713 220-380V 60HZ 3PH-(4WIRE)
Pulley-2AK74-5/8	027822	2		103	200V 50/60HZ 3PH/220-380V 60HZ 3PH-4WIRE
Pulley-2AK27 X .625-.6265	011545	2	2	103	200V 50HZ 3PH/220-240V 50HZ 3PH/220-240V 50HZ 1PH/380-415V 50HZ 3N~(4WIRE)
Pulley-2AK22-7/8	019987	2	2	103	220-380V 60HZ 3PH-4 WIRE
Starter-1 Phase 6.3 to 10 AMP	066794-27K	2	2	103	220-240V 50HZ 1PH
Starter-3 Phase 4 to 6.5	066794-33J	2		103	220-240V 50HZ 3PH/200V 50/60HZ 3PH

Description	Part Number	C712 Qty.	C713 Qty.	Warr. Class	Remarks
Starter-3 Phase 2.5 to 4 AMP	066794-33H	2	2	103	380-415V 50HZ 3N~ (4WIRE)/220-380V 60HZ 3PH-4WIRE
<b>Distributor Installed Options</b>					
Switch A.-Dual Lever	X62400	*		103	
Actuator A.-Draw Switch	X62401	*		103	
Kit A.-Art.Faucet-Twin/PU	X29301-SER	*	*	103	
Kit A.-Central Faucet *Console	X44783		*	103	
Kit A.-Cone Dispenser-4 T	X41141	*	*	103	
Kit A.-Syrup Rail-Side MO	X48014-12	*	*	103	
Kit A.-Syrup Rail-Side MO	X48014-27	*	*	103	
Spinner A.-Panel w/Filter	X50276-27	*	*	103	
Kit A.-Hopper Lock-Twin	X59106	*	*	103	
Kit A.-Lock-Draw Valve-TW	X62504-SER	*	*	103	
Tray-Parts-Barrel-3.4 QT*	067431	*	*	000	
Tray-Parts-Pump-Simplifie	056525	*		000	
Adaptor-Spout-Hose-Drain	063018	*	*	103	
<b>C71233F836 M C712 DQ</b>					
Diagram-Wiring *C712*DQ*	05989833DQ	1		000	
Door A.-LG BAF*W/PRG*C712*DQ	X59921SER1	1		103	
+Baffle A.-Long 4 IN W/RAD TH	X50882	2		103	
+Bearing-Front-Shoe	050348	2		000	
+Decal-Door-3 Spout-Twin TWIS	062239	1		000	
+Gasket-Door HT 4"-Double	048926	2		000	
+O-ring-1-1/4 OD X .139W	008667	9		000	
+O-ring-3/8 OD X .070W	016137	4		000	
+O-ring-7/8 OD X .139W	025307	4		000	

Description	Part Number	C712 Qty.	C713 Qty.	Warr. Class	Remarks
+Plug-Prime	028805	2		103	
+Valve A.-Draw *DQ* Twin Cent	X51075	1		103	
+Valve A.-Draw *DQ*Twin L/R	X43853-SP	2		103	
Harness-Wire-LW V-CNTRL-C	066444-SP	1		103	
Kit A.-Tune C712DQ Simple	X49463-86	1		000	
Switch A.-Draw *C712*DQ*	X80017	1		103	
Arm A.-Draw Valve *C712*DQ*	X80015	3		103	
Bracket A.-Switch-Draw*C712*	X80018	1		103	
E-ring External 1/2 Rotoclip	024908	6		103	
Nut-4-40 Hex-SS	038623	6		103	
Screw-4-40X1 SLTD Round	028890	2		000	
Screw-4-40X5/8 SLTD Round	027219	4		000	
Spring-Return L.	023487	3		103	
Switch-Lever-SPDT-11A-125-27	039252	4		103	
<b>Adjustable Feed</b>					
Tube A.-Feed-Inner-Air/MI	X67103		2	103	
Tube A.-Feed-Outer-HT	X67104		2	103	
O-ring-.291 ID X .080W	018550		6	000	
O-ring-.643 OD X .077W	018572		4	000	
Kit A.-Tune Up-3 SPT C713	X49463-80A		1	000	
<b>C713 - Hopper Agitator</b>					
Blade A.-Agitator *C708*	X56591	2		103	Standard
Blade A.-Agitator-w/Holes	X66334		2	103	Special-PB
Capacitor-Motor-Agitator	057525		2	103	
Diagram-Wiring *C712*AGIT	05989827HA	1		000	

5-18

+ Available Separately

Models C712/C713

Parts List

Description	Part Number	C712 Qty.	C713 Qty.	Warr. Class	Remarks
Diagram-Wiring *C713*AGIT	05989933HA		1	000	
Housing A.-Agitator *C708	X56586-03	2	2	103	
Body-Agitator Housing *C708*	056588	2	1	103	
Cap-Agitator Housing	080827	2	1	103	
Magnet A.-Agitator-Inner	066937	2	1	103	
Motor-Agitator-24VAC 50/60 H	050535-03	2	1	103	
O-ring-1-3/8 OD X .070W	017395	2	1	000	
Plate-Holding-Agitator *C708	056587	2	1	103	
Screw-4-40X1/4 Socket Head	600165	8	4	000	
Screw-8-32X3/16 Socket Set	006812	4	2	000	
Shell A.-Insulated *C712*	X65598	1		512	
Shell A.-Insulated *C713*	X65599		1	512	
Tube A.-Feed-SS-7/32 Hole	X29429-4	2	2	103	Added as of M3071813
<b>Integrated Syrup Rail</b>					
Jar-Syrup*Plastic*Shallow	036573	2	2	103	
Jar-Syrup*Stainless*Shall	036574	2	2	103	
Ladle-1 OZ-120D Bend IN H	033637-1	2	2	103	
Lid-Syrup Jar	042706	2	2	103	
Panel A.-Front-Syr Rail *	X63884-27	1	1	103	
Pump A.-Syrup-Heated-Brn	X53800-BRN	1	1	103	
Pump A.-Syrup-Heated-Tan	X53800-TAN	1	1	103	
Tray-Drip-SYR-C716	063876	1	1	103	
<b>Optional Rear Mix Low Lights</b>					
Trim A.-Corner-Lights	X81330		1	103	
Decal-Rear Mix Lights	069413		1	000	

Description	Part Number	C712 Qty.	C713 Qty.	Warr. Class	Remarks
PCB A.-LED-4 Position	X63930-SER		1	212	
Standoff-Nylon 6-32X1/2L SNA	040280-002		2	000	
Trim A.-Rear Corner L	X81329		1	103	
Harness-Rear Mix Lights	081703		1	103	

+ Available Separately

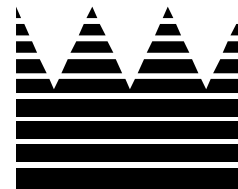

## **Section 6: Wiring Diagrams**

- **Diagram 059898-27 (C712)**
- **Diagram 059898-33 (C712)**
- **Diagram 059898-40 (C712)**
- **Diagram 059898-58 (C712)**
- **Diagram 059899-27 (C713)**
- **Diagram 059899-33 (C713)**
- **Diagram 059899-40 (C713)**
- **Diagram 059899-58 (C713)**

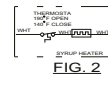
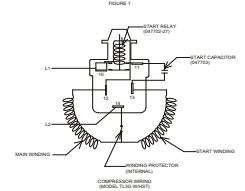
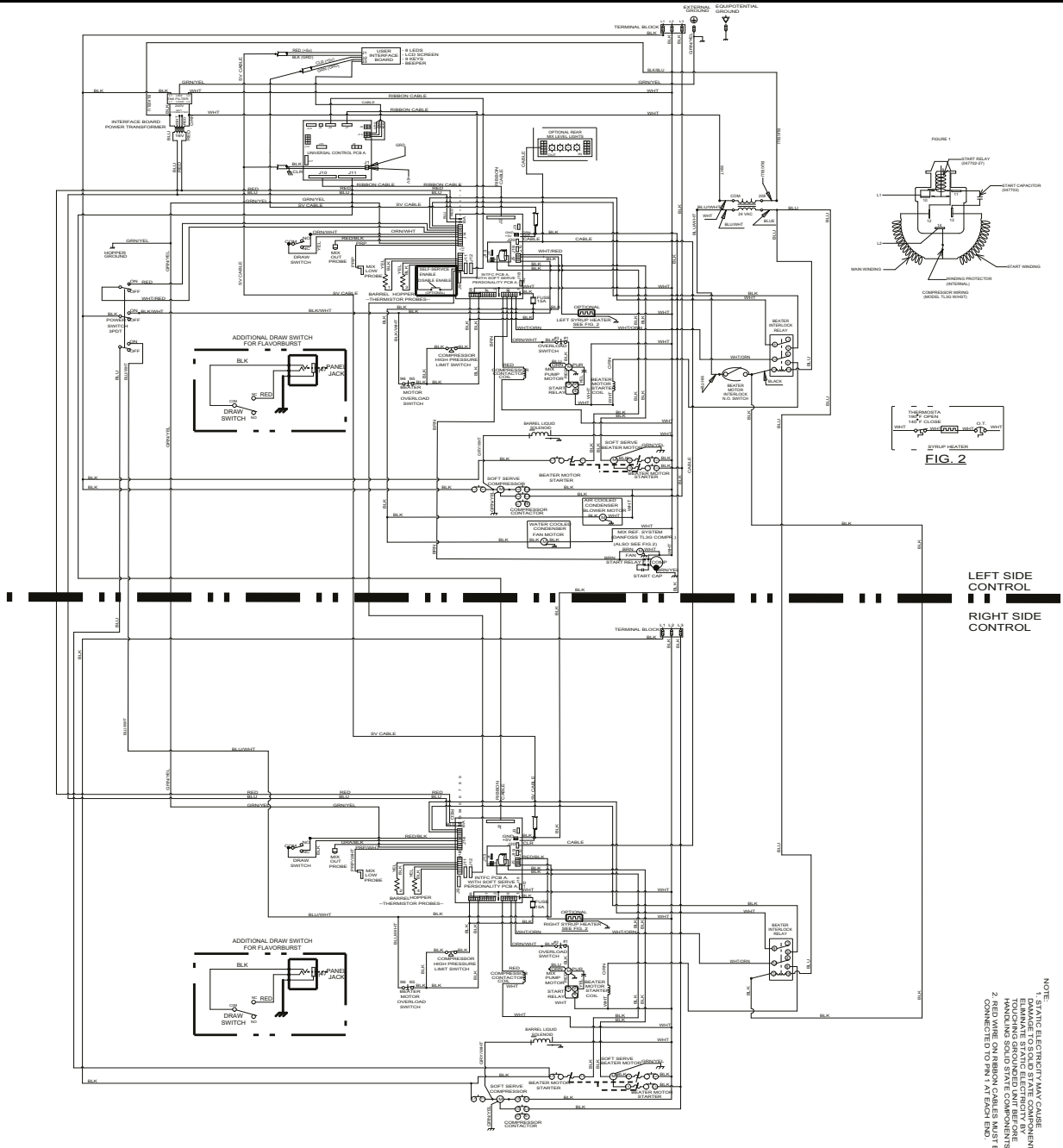

LEFT SIDE CONTROL  
RIGHT SIDE CONTROL

NOTE:  
1. DAMAGE TO SOLID STATE COMPONENTS  
ELEMANTING STATIC ELECTRICITY BY  
HANDLING SOLID STATE COMPONENTS.  
2. RED WIRE ON REBORN CABLES MUST BE  
CONNECTED TO 120V/1A SWITCH ONLY.

GROUND FRAME SECURELY

\* IF THE UNIT HAS THE INTEGRAL STRIP OPTIONS, THEN THIS JUMPER SHOULD BE INSTALLED.

WIRE BOARD	JUMPER SETTINGS	JUMPER INSTALLED
W1	RESERVED (DO NOT USE)	NO
W2	RESERVED (DO NOT USE)	NO
W3	RESERVED (DO NOT USE)	NO
W4	RESERVED (DO NOT USE)	NO
W5	RESERVED (DO NOT USE)	NO
W6	RESERVED (DO NOT USE)	NO
W7	RESERVED (DO NOT USE)	NO
W8	RESERVED (DO NOT USE)	NO
W9	RESERVED (DO NOT USE)	NO
W10	RESERVED (DO NOT USE)	NO
W11	RESERVED (DO NOT USE)	NO
W12	RESERVED (DO NOT USE)	NO
W13	RESERVED (DO NOT USE)	NO
W14	RESERVED (DO NOT USE)	NO
W15	RESERVED (DO NOT USE)	NO
W16	RESERVED (DO NOT USE)	NO
W17	RESERVED (DO NOT USE)	NO
W18	RESERVED (DO NOT USE)	NO
W19	RESERVED (DO NOT USE)	NO
W20	RESERVED (DO NOT USE)	NO
W21	RESERVED (DO NOT USE)	NO
W22	RESERVED (DO NOT USE)	NO
W23	RESERVED (DO NOT USE)	NO
W24	RESERVED (DO NOT USE)	NO
W25	RESERVED (DO NOT USE)	NO
W26	RESERVED (DO NOT USE)	NO
W27	RESERVED (DO NOT USE)	NO
W28	RESERVED (DO NOT USE)	NO
W29	RESERVED (DO NOT USE)	NO
W30	RESERVED (DO NOT USE)	NO
W31	RESERVED (DO NOT USE)	NO
W32	RESERVED (DO NOT USE)	NO
W33	RESERVED (DO NOT USE)	NO
W34	RESERVED (DO NOT USE)	NO
W35	RESERVED (DO NOT USE)	NO
W36	RESERVED (DO NOT USE)	NO
W37	RESERVED (DO NOT USE)	NO
W38	RESERVED (DO NOT USE)	NO
W39	RESERVED (DO NOT USE)	NO
W40	RESERVED (DO NOT USE)	NO
W41	RESERVED (DO NOT USE)	NO
W42	RESERVED (DO NOT USE)	NO
W43	RESERVED (DO NOT USE)	NO
W44	RESERVED (DO NOT USE)	NO
W45	RESERVED (DO NOT USE)	NO
W46	RESERVED (DO NOT USE)	NO
W47	RESERVED (DO NOT USE)	NO
W48	RESERVED (DO NOT USE)	NO
W49	RESERVED (DO NOT USE)	NO
W50	RESERVED (DO NOT USE)	NO
W51	RESERVED (DO NOT USE)	NO
W52	RESERVED (DO NOT USE)	NO
W53	RESERVED (DO NOT USE)	NO
W54	RESERVED (DO NOT USE)	NO
W55	RESERVED (DO NOT USE)	NO
W56	RESERVED (DO NOT USE)	NO
W57	RESERVED (DO NOT USE)	NO
W58	RESERVED (DO NOT USE)	NO
W59	RESERVED (DO NOT USE)	NO
W60	RESERVED (DO NOT USE)	NO
W61	RESERVED (DO NOT USE)	NO
W62	RESERVED (DO NOT USE)	NO
W63	RESERVED (DO NOT USE)	NO
W64	RESERVED (DO NOT USE)	NO
W65	RESERVED (DO NOT USE)	NO
W66	RESERVED (DO NOT USE)	NO
W67	RESERVED (DO NOT USE)	NO
W68	RESERVED (DO NOT USE)	NO
W69	RESERVED (DO NOT USE)	NO
W70	RESERVED (DO NOT USE)	NO
W71	RESERVED (DO NOT USE)	NO
W72	RESERVED (DO NOT USE)	NO
W73	RESERVED (DO NOT USE)	NO
W74	RESERVED (DO NOT USE)	NO
W75	RESERVED (DO NOT USE)	NO
W76	RESERVED (DO NOT USE)	NO
W77	RESERVED (DO NOT USE)	NO
W78	RESERVED (DO NOT USE)	NO
W79	RESERVED (DO NOT USE)	NO
W80	RESERVED (DO NOT USE)	NO
W81	RESERVED (DO NOT USE)	NO
W82	RESERVED (DO NOT USE)	NO
W83	RESERVED (DO NOT USE)	NO
W84	RESERVED (DO NOT USE)	NO
W85	RESERVED (DO NOT USE)	NO
W86	RESERVED (DO NOT USE)	NO
W87	RESERVED (DO NOT USE)	NO
W88	RESERVED (DO NOT USE)	NO
W89	RESERVED (DO NOT USE)	NO
W90	RESERVED (DO NOT USE)	NO
W91	RESERVED (DO NOT USE)	NO
W92	RESERVED (DO NOT USE)	NO
W93	RESERVED (DO NOT USE)	NO
W94	RESERVED (DO NOT USE)	NO
W95	RESERVED (DO NOT USE)	NO
W96	RESERVED (DO NOT USE)	NO
W97	RESERVED (DO NOT USE)	NO
W98	RESERVED (DO NOT USE)	NO
W99	RESERVED (DO NOT USE)	NO
W100	RESERVED (DO NOT USE)	NO
W101	RESERVED (DO NOT USE)	NO
W102	RESERVED (DO NOT USE)	NO
W103	RESERVED (DO NOT USE)	NO
W104	RESERVED (DO NOT USE)	NO
W105	RESERVED (DO NOT USE)	NO
W106	RESERVED (DO NOT USE)	NO
W107	RESERVED (DO NOT USE)	NO
W108	RESERVED (DO NOT USE)	NO
W109	RESERVED (DO NOT USE)	NO
W110	RESERVED (DO NOT USE)	NO
W111	RESERVED (DO NOT USE)	NO
W112	RESERVED (DO NOT USE)	NO
W113	RESERVED (DO NOT USE)	NO
W114	RESERVED (DO NOT USE)	NO
W115	RESERVED (DO NOT USE)	NO
W116	RESERVED (DO NOT USE)	NO
W117	RESERVED (DO NOT USE)	NO
W118	RESERVED (DO NOT USE)	NO
W119	RESERVED (DO NOT USE)	NO
W120	RESERVED (DO NOT USE)	NO
W121	RESERVED (DO NOT USE)	NO
W122	RESERVED (DO NOT USE)	NO
W123	RESERVED (DO NOT USE)	NO
W124	RESERVED (DO NOT USE)	NO
W125	RESERVED (DO NOT USE)	NO
W126	RESERVED (DO NOT USE)	NO
W127	RESERVED (DO NOT USE)	NO
W128	RESERVED (DO NOT USE)	NO
W129	RESERVED (DO NOT USE)	NO
W130	RESERVED (DO NOT USE)	NO
W131	RESERVED (DO NOT USE)	NO
W132	RESERVED (DO NOT USE)	NO
W133	RESERVED (DO NOT USE)	NO
W134	RESERVED (DO NOT USE)	NO
W135	RESERVED (DO NOT USE)	NO
W136	RESERVED (DO NOT USE)	NO
W137	RESERVED (DO NOT USE)	NO
W138	RESERVED (DO NOT USE)	NO
W139	RESERVED (DO NOT USE)	NO
W140	RESERVED (DO NOT USE)	NO
W141	RESERVED (DO NOT USE)	NO
W142	RESERVED (DO NOT USE)	NO
W143	RESERVED (DO NOT USE)	NO
W144	RESERVED (DO NOT USE)	NO
W145	RESERVED (DO NOT USE)	NO
W146	RESERVED (DO NOT USE)	NO
W147	RESERVED (DO NOT USE)	NO
W148	RESERVED (DO NOT USE)	NO
W149	RESERVED (DO NOT USE)	NO
W150	RESERVED (DO NOT USE)	NO
W151	RESERVED (DO NOT USE)	NO
W152	RESERVED (DO NOT USE)	NO
W153	RESERVED (DO NOT USE)	NO
W154	RESERVED (DO NOT USE)	NO
W155	RESERVED (DO NOT USE)	NO
W156	RESERVED (DO NOT USE)	NO
W157	RESERVED (DO NOT USE)	NO
W158	RESERVED (DO NOT USE)	NO
W159	RESERVED (DO NOT USE)	NO
W160	RESERVED (DO NOT USE)	NO
W161	RESERVED (DO NOT USE)	NO
W162	RESERVED (DO NOT USE)	NO
W163	RESERVED (DO NOT USE)	NO
W164	RESERVED (DO NOT USE)	NO
W165	RESERVED (DO NOT USE)	NO
W166	RESERVED (DO NOT USE)	NO
W167	RESERVED (DO NOT USE)	NO
W168	RESERVED (DO NOT USE)	NO
W169	RESERVED (DO NOT USE)	NO
W170	RESERVED (DO NOT USE)	NO
W171	RESERVED (DO NOT USE)	NO
W172	RESERVED (DO NOT USE)	NO
W173	RESERVED (DO NOT USE)	NO
W174	RESERVED (DO NOT USE)	NO
W175	RESERVED (DO NOT USE)	NO
W176	RESERVED (DO NOT USE)	NO
W177	RESERVED (DO NOT USE)	NO
W178	RESERVED (DO NOT USE)	NO
W179	RESERVED (DO NOT USE)	NO
W180	RESERVED (DO NOT USE)	NO
W181	RESERVED (DO NOT USE)	NO
W182	RESERVED (DO NOT USE)	NO
W183	RESERVED (DO NOT USE)	NO
W184	RESERVED (DO NOT USE)	NO
W185	RESERVED (DO NOT USE)	NO
W186	RESERVED (DO NOT USE)	NO
W187	RESERVED (DO NOT USE)	NO
W188	RESERVED (DO NOT USE)	NO
W189	RESERVED (DO NOT USE)	NO
W190	RESERVED (DO NOT USE)	NO
W191	RESERVED (DO NOT USE)	NO
W192	RESERVED (DO NOT USE)	NO
W193	RESERVED (DO NOT USE)	NO
W194	RESERVED (DO NOT USE)	NO
W195	RESERVED (DO NOT USE)	NO
W196	RESERVED (DO NOT USE)	NO
W197	RESERVED (DO NOT USE)	NO
W198	RESERVED (DO NOT USE)	NO
W199	RESERVED (DO NOT USE)	NO
W200	RESERVED (DO NOT USE)	NO

Figure 6-1 Diagram 059898-27 (C712)



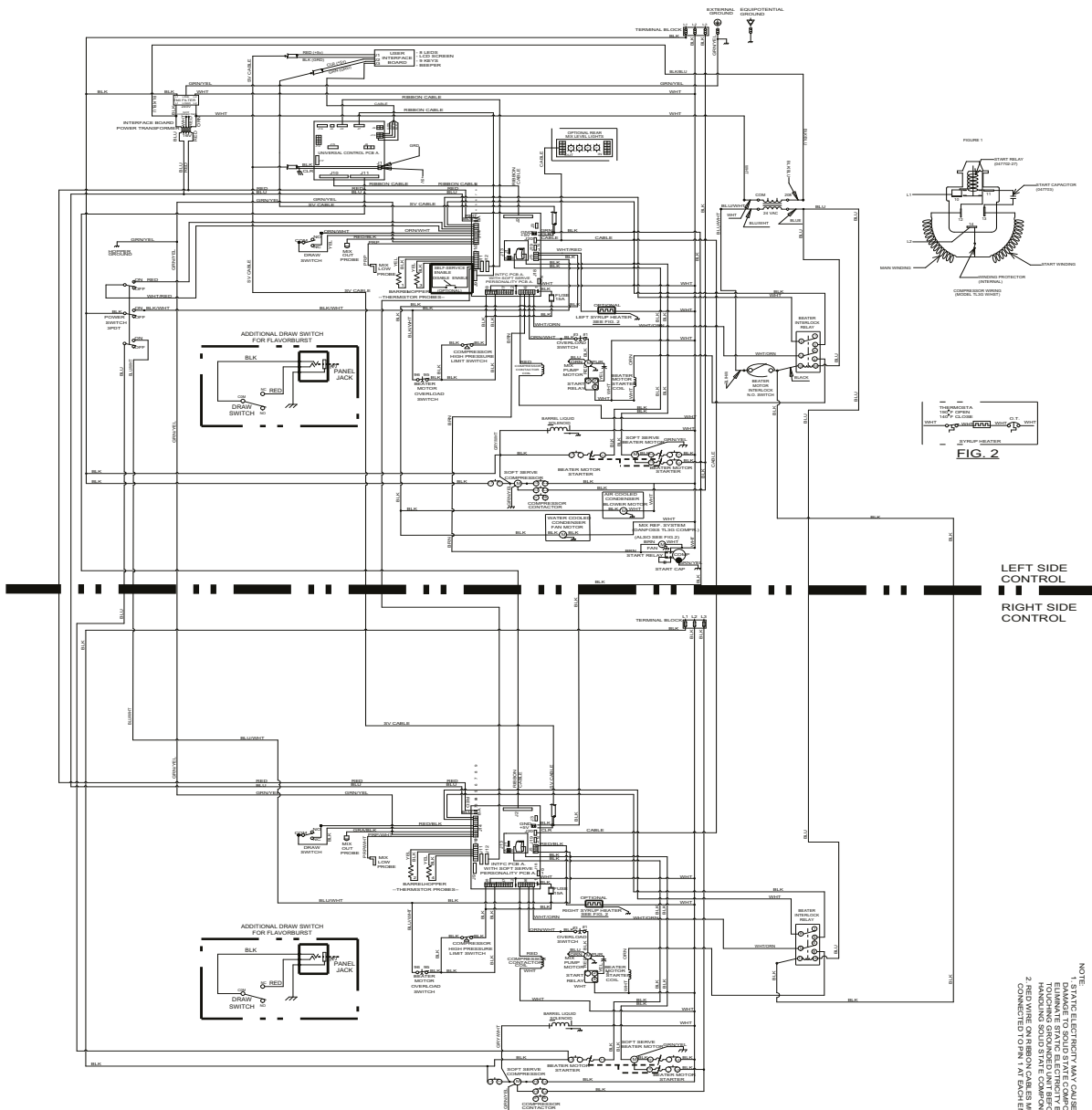

LEFT SIDE CONTROL  
RIGHT SIDE CONTROL

6

NOTE:  
1. A NOTE ELECTRICITY MAY CAUSE DAMAGE TO SOLID STATE COMPONENTS. EQUIPOTENTIAL OPERATOR IS INSTALLED TO PROTECT THE HANDLING SOLID STATE COMPONENTS. 2. A NOTE ON PINS 1 AND 2 SHOULD BE CONSULTED TO PIN 1 AT EACH END.

UICC BOARD	FUNCTION	JAMBER SETTINGS	JAMBER INITIALLY
J1	POWER SUPPLY	NO	NO
J2	POWER SUPPLY	NO	NO
J3	POWER SUPPLY	NO	NO
J4	POWER SUPPLY	NO	NO
J5	POWER SUPPLY	NO	NO
J6	POWER SUPPLY	NO	NO
J7	POWER SUPPLY	NO	NO
J8	POWER SUPPLY	NO	NO
J9	POWER SUPPLY	NO	NO
J10	POWER SUPPLY	NO	NO
J11	POWER SUPPLY	NO	NO
J12	POWER SUPPLY	NO	NO
J13	POWER SUPPLY	NO	NO
J14	POWER SUPPLY	NO	NO
J15	POWER SUPPLY	NO	NO
J16	POWER SUPPLY	NO	NO
J17	POWER SUPPLY	NO	NO
J18	POWER SUPPLY	NO	NO
J19	POWER SUPPLY	NO	NO
J20	POWER SUPPLY	NO	NO
J21	POWER SUPPLY	NO	NO
J22	POWER SUPPLY	NO	NO
J23	POWER SUPPLY	NO	NO
J24	POWER SUPPLY	NO	NO
J25	POWER SUPPLY	NO	NO
J26	POWER SUPPLY	NO	NO
J27	POWER SUPPLY	NO	NO
J28	POWER SUPPLY	NO	NO
J29	POWER SUPPLY	NO	NO
J30	POWER SUPPLY	NO	NO
J31	POWER SUPPLY	NO	NO
J32	POWER SUPPLY	NO	NO
J33	POWER SUPPLY	NO	NO
J34	POWER SUPPLY	NO	NO
J35	POWER SUPPLY	NO	NO
J36	POWER SUPPLY	NO	NO
J37	POWER SUPPLY	NO	NO
J38	POWER SUPPLY	NO	NO
J39	POWER SUPPLY	NO	NO
J40	POWER SUPPLY	NO	NO
J41	POWER SUPPLY	NO	NO
J42	POWER SUPPLY	NO	NO
J43	POWER SUPPLY	NO	NO
J44	POWER SUPPLY	NO	NO
J45	POWER SUPPLY	NO	NO
J46	POWER SUPPLY	NO	NO
J47	POWER SUPPLY	NO	NO
J48	POWER SUPPLY	NO	NO
J49	POWER SUPPLY	NO	NO
J50	POWER SUPPLY	NO	NO
J51	POWER SUPPLY	NO	NO
J52	POWER SUPPLY	NO	NO
J53	POWER SUPPLY	NO	NO
J54	POWER SUPPLY	NO	NO
J55	POWER SUPPLY	NO	NO
J56	POWER SUPPLY	NO	NO
J57	POWER SUPPLY	NO	NO
J58	POWER SUPPLY	NO	NO
J59	POWER SUPPLY	NO	NO
J60	POWER SUPPLY	NO	NO
J61	POWER SUPPLY	NO	NO
J62	POWER SUPPLY	NO	NO
J63	POWER SUPPLY	NO	NO
J64	POWER SUPPLY	NO	NO
J65	POWER SUPPLY	NO	NO
J66	POWER SUPPLY	NO	NO
J67	POWER SUPPLY	NO	NO
J68	POWER SUPPLY	NO	NO
J69	POWER SUPPLY	NO	NO
J70	POWER SUPPLY	NO	NO
J71	POWER SUPPLY	NO	NO
J72	POWER SUPPLY	NO	NO
J73	POWER SUPPLY	NO	NO
J74	POWER SUPPLY	NO	NO
J75	POWER SUPPLY	NO	NO
J76	POWER SUPPLY	NO	NO
J77	POWER SUPPLY	NO	NO
J78	POWER SUPPLY	NO	NO
J79	POWER SUPPLY	NO	NO
J80	POWER SUPPLY	NO	NO
J81	POWER SUPPLY	NO	NO
J82	POWER SUPPLY	NO	NO
J83	POWER SUPPLY	NO	NO
J84	POWER SUPPLY	NO	NO
J85	POWER SUPPLY	NO	NO
J86	POWER SUPPLY	NO	NO
J87	POWER SUPPLY	NO	NO
J88	POWER SUPPLY	NO	NO
J89	POWER SUPPLY	NO	NO
J90	POWER SUPPLY	NO	NO
J91	POWER SUPPLY	NO	NO
J92	POWER SUPPLY	NO	NO
J93	POWER SUPPLY	NO	NO
J94	POWER SUPPLY	NO	NO
J95	POWER SUPPLY	NO	NO
J96	POWER SUPPLY	NO	NO
J97	POWER SUPPLY	NO	NO
J98	POWER SUPPLY	NO	NO
J99	POWER SUPPLY	NO	NO
J100	POWER SUPPLY	NO	NO

GROUND FRAME SECURELY

Model C712  
059898-33  
09/14

© 2014 Taylor Company  
Figure 6-2 Diagram 059898-33 (C712)

# WIRING DIAGRAMS

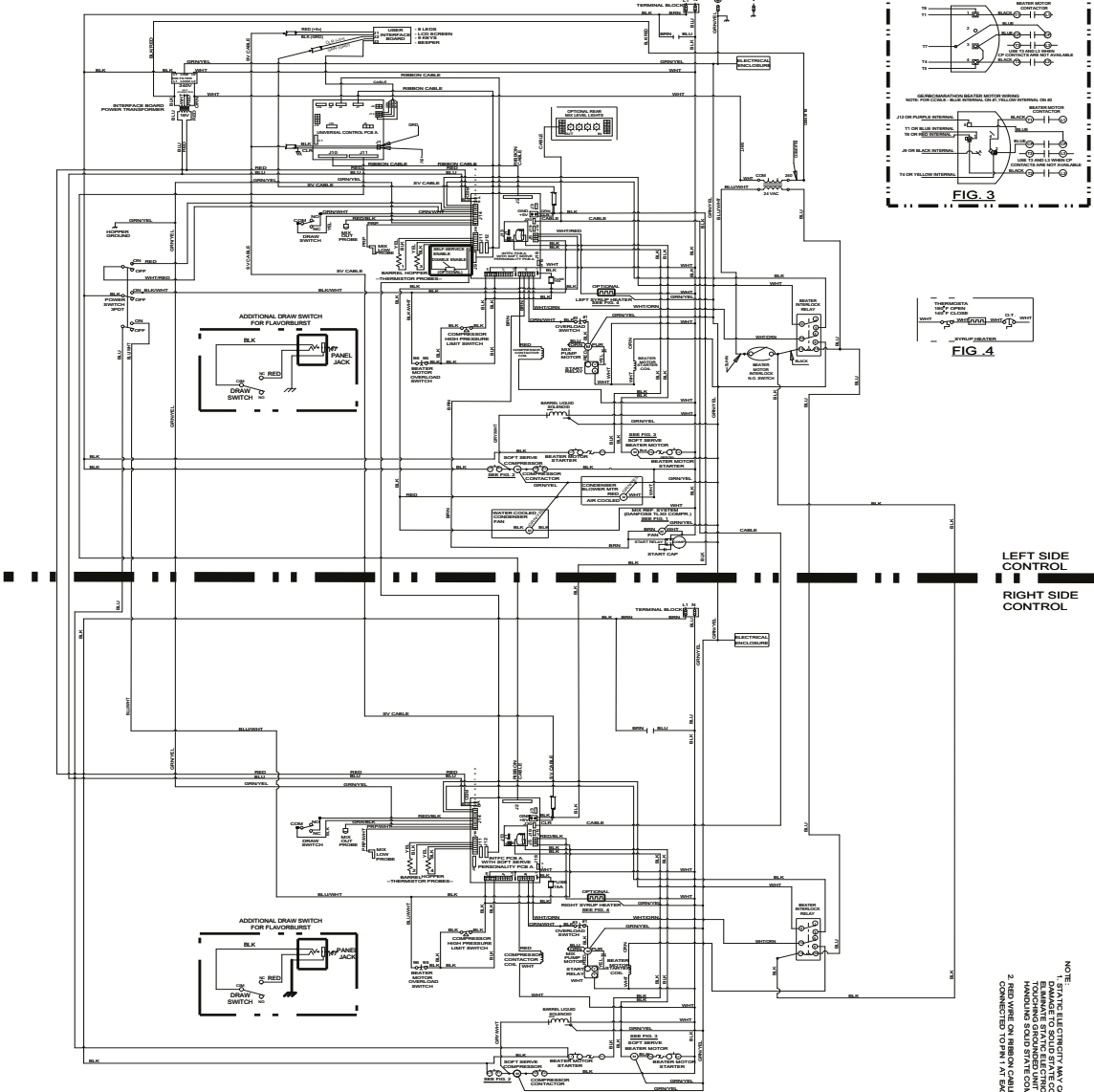
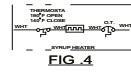
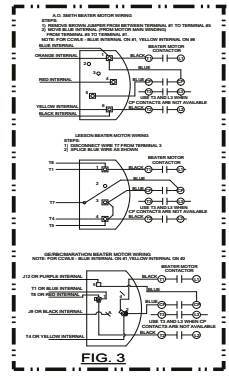
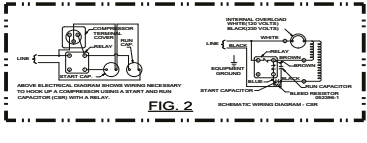
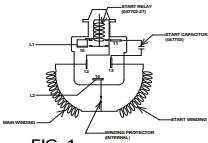

LEFT SIDE CONTROL  
RIGHT SIDE CONTROL

NOTE:  
1. NAME PLATE CONTAINS MAIN CURRENTS.  
2. NAME PLATE CONTAINS STATE COMPONENTS.  
3. BLANK NAME PLATE INDICATES THE UNIT IS A HANDLING SOLID STATE COMPONENTS.  
4. RED WIRES ON RIBBON CABLES MUST BE CONNECTED TO 11V AC (50/60 HZ).

WIRE	FUNCTION	WIRING	INITIAL
W1	RESERVED FOR CONTACT USE	NO	NO
W2	RESERVED FOR CONTACT USE	NO	NO
W3	RESERVED FOR CONTACT USE	NO	NO
W4	RESERVED FOR CONTACT USE	NO	NO
W5	RESERVED FOR CONTACT USE	NO	NO
W6	RESERVED FOR CONTACT USE	NO	NO
W7	RESERVED FOR CONTACT USE	NO	NO
W8	RESERVED FOR CONTACT USE	NO	NO
W9	RESERVED FOR CONTACT USE	NO	NO
W10	RESERVED FOR CONTACT USE	NO	NO
W11	RESERVED FOR CONTACT USE	NO	NO
W12	RESERVED FOR CONTACT USE	NO	NO
W13	RESERVED FOR CONTACT USE	NO	NO
W14	RESERVED FOR CONTACT USE	NO	NO
W15	RESERVED FOR CONTACT USE	NO	NO
W16	RESERVED FOR CONTACT USE	NO	NO
W17	RESERVED FOR CONTACT USE	NO	NO
W18	RESERVED FOR CONTACT USE	NO	NO
W19	RESERVED FOR CONTACT USE	NO	NO
W20	RESERVED FOR CONTACT USE	NO	NO
W21	RESERVED FOR CONTACT USE	NO	NO
W22	RESERVED FOR CONTACT USE	NO	NO
W23	RESERVED FOR CONTACT USE	NO	NO
W24	RESERVED FOR CONTACT USE	NO	NO
W25	RESERVED FOR CONTACT USE	NO	NO
W26	RESERVED FOR CONTACT USE	NO	NO
W27	RESERVED FOR CONTACT USE	NO	NO
W28	RESERVED FOR CONTACT USE	NO	NO
W29	RESERVED FOR CONTACT USE	NO	NO
W30	RESERVED FOR CONTACT USE	NO	NO
W31	RESERVED FOR CONTACT USE	NO	NO
W32	RESERVED FOR CONTACT USE	NO	NO
W33	RESERVED FOR CONTACT USE	NO	NO
W34	RESERVED FOR CONTACT USE	NO	NO
W35	RESERVED FOR CONTACT USE	NO	NO
W36	RESERVED FOR CONTACT USE	NO	NO
W37	RESERVED FOR CONTACT USE	NO	NO
W38	RESERVED FOR CONTACT USE	NO	NO
W39	RESERVED FOR CONTACT USE	NO	NO
W40	RESERVED FOR CONTACT USE	NO	NO
W41	RESERVED FOR CONTACT USE	NO	NO
W42	RESERVED FOR CONTACT USE	NO	NO
W43	RESERVED FOR CONTACT USE	NO	NO
W44	RESERVED FOR CONTACT USE	NO	NO
W45	RESERVED FOR CONTACT USE	NO	NO
W46	RESERVED FOR CONTACT USE	NO	NO
W47	RESERVED FOR CONTACT USE	NO	NO
W48	RESERVED FOR CONTACT USE	NO	NO
W49	RESERVED FOR CONTACT USE	NO	NO
W50	RESERVED FOR CONTACT USE	NO	NO
W51	RESERVED FOR CONTACT USE	NO	NO
W52	RESERVED FOR CONTACT USE	NO	NO
W53	RESERVED FOR CONTACT USE	NO	NO
W54	RESERVED FOR CONTACT USE	NO	NO
W55	RESERVED FOR CONTACT USE	NO	NO
W56	RESERVED FOR CONTACT USE	NO	NO
W57	RESERVED FOR CONTACT USE	NO	NO
W58	RESERVED FOR CONTACT USE	NO	NO
W59	RESERVED FOR CONTACT USE	NO	NO
W60	RESERVED FOR CONTACT USE	NO	NO
W61	RESERVED FOR CONTACT USE	NO	NO
W62	RESERVED FOR CONTACT USE	NO	NO
W63	RESERVED FOR CONTACT USE	NO	NO
W64	RESERVED FOR CONTACT USE	NO	NO
W65	RESERVED FOR CONTACT USE	NO	NO
W66	RESERVED FOR CONTACT USE	NO	NO
W67	RESERVED FOR CONTACT USE	NO	NO
W68	RESERVED FOR CONTACT USE	NO	NO
W69	RESERVED FOR CONTACT USE	NO	NO
W70	RESERVED FOR CONTACT USE	NO	NO
W71	RESERVED FOR CONTACT USE	NO	NO
W72	RESERVED FOR CONTACT USE	NO	NO
W73	RESERVED FOR CONTACT USE	NO	NO
W74	RESERVED FOR CONTACT USE	NO	NO
W75	RESERVED FOR CONTACT USE	NO	NO
W76	RESERVED FOR CONTACT USE	NO	NO
W77	RESERVED FOR CONTACT USE	NO	NO
W78	RESERVED FOR CONTACT USE	NO	NO
W79	RESERVED FOR CONTACT USE	NO	NO
W80	RESERVED FOR CONTACT USE	NO	NO
W81	RESERVED FOR CONTACT USE	NO	NO
W82	RESERVED FOR CONTACT USE	NO	NO
W83	RESERVED FOR CONTACT USE	NO	NO
W84	RESERVED FOR CONTACT USE	NO	NO
W85	RESERVED FOR CONTACT USE	NO	NO
W86	RESERVED FOR CONTACT USE	NO	NO
W87	RESERVED FOR CONTACT USE	NO	NO
W88	RESERVED FOR CONTACT USE	NO	NO
W89	RESERVED FOR CONTACT USE	NO	NO
W90	RESERVED FOR CONTACT USE	NO	NO
W91	RESERVED FOR CONTACT USE	NO	NO
W92	RESERVED FOR CONTACT USE	NO	NO
W93	RESERVED FOR CONTACT USE	NO	NO
W94	RESERVED FOR CONTACT USE	NO	NO
W95	RESERVED FOR CONTACT USE	NO	NO
W96	RESERVED FOR CONTACT USE	NO	NO
W97	RESERVED FOR CONTACT USE	NO	NO
W98	RESERVED FOR CONTACT USE	NO	NO
W99	RESERVED FOR CONTACT USE	NO	NO
W100	RESERVED FOR CONTACT USE	NO	NO

GROUND FRAME SECURELY

6

© 2014 Taylor Company  
Figure 6-3 Diagram 059898-40 (C712)

Model C712  
059898-40  
09/14







# WIRING DIAGRAMS

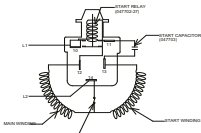

FIG. 1

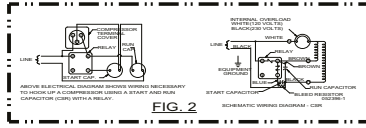

FIG. 2

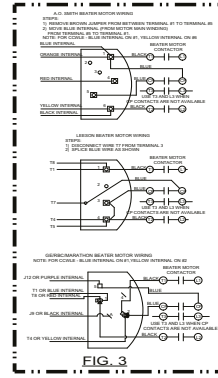

FIG. 3

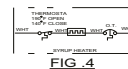
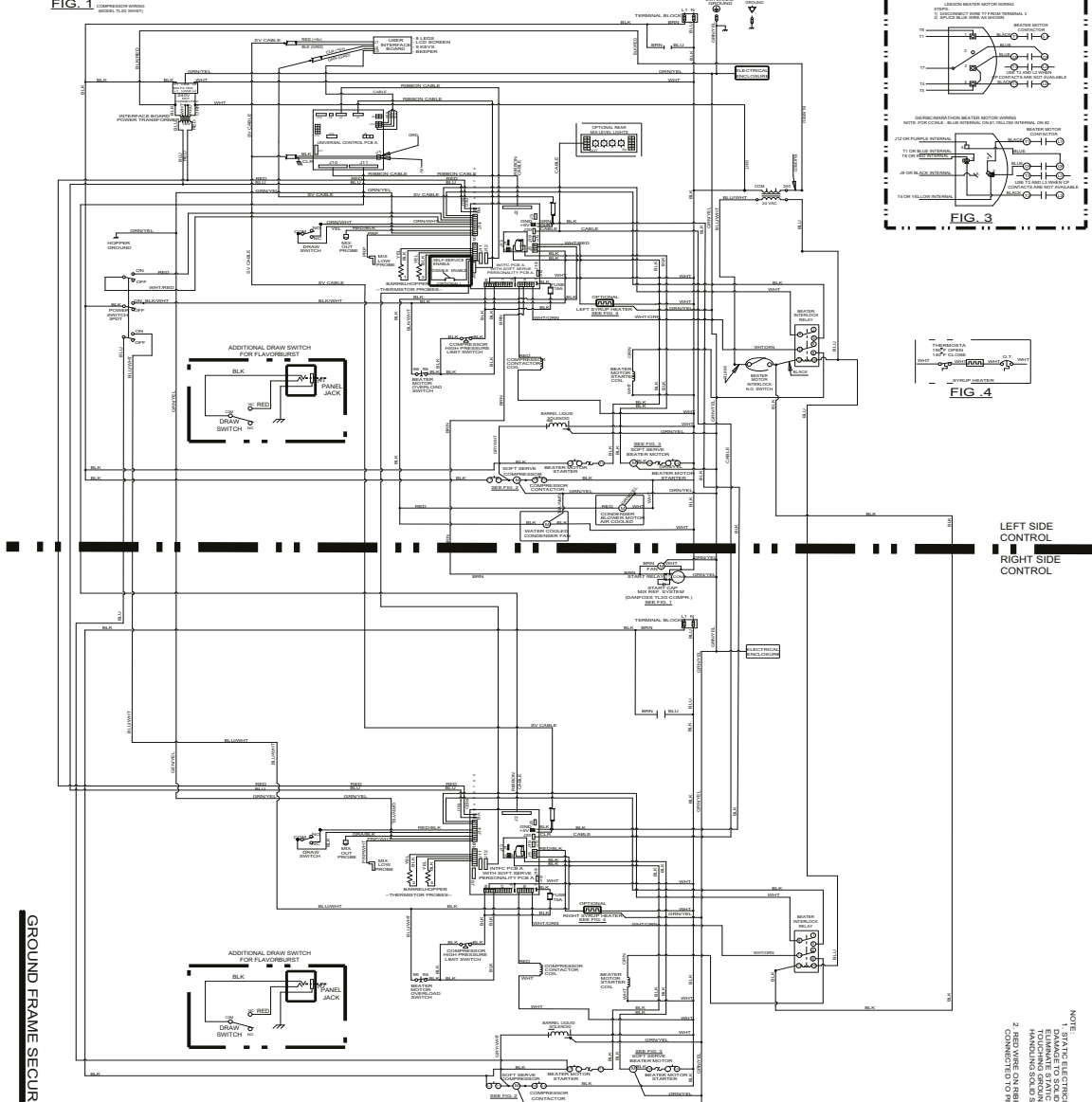

FIG. 4



LEFT SIDE CONTROL  
RIGHT SIDE CONTROL

6

GROUND FRAME SECURELY

U/I/O BOARD	FUNCTION	JAMBER INSTALLED
JP1	RESERVED FOR USE	NO
JP2	RESERVED FOR USE	NO
JP3	RESERVED FOR USE	NO
JP4	RESERVED FOR USE	NO
JP5	RESERVED FOR USE	NO
JP6	RESERVED FOR USE	NO
JP7	RESERVED FOR USE	NO
JP8	RESERVED FOR USE	NO
JP9	RESERVED FOR USE	NO
JP10	RESERVED FOR USE	NO
JP11	RESERVED FOR USE	NO
JP12	RESERVED FOR USE	NO
JP13	RESERVED FOR USE	NO
JP14	RESERVED FOR USE	NO
JP15	RESERVED FOR USE	NO
JP16	RESERVED FOR USE	NO
JP17	RESERVED FOR USE	NO
JP18	RESERVED FOR USE	NO
JP19	RESERVED FOR USE	NO
JP20	RESERVED FOR USE	NO
JP21	RESERVED FOR USE	NO
JP22	RESERVED FOR USE	NO
JP23	RESERVED FOR USE	NO
JP24	RESERVED FOR USE	NO
JP25	RESERVED FOR USE	NO
JP26	RESERVED FOR USE	NO
JP27	RESERVED FOR USE	NO
JP28	RESERVED FOR USE	NO
JP29	RESERVED FOR USE	NO
JP30	RESERVED FOR USE	NO
JP31	RESERVED FOR USE	NO
JP32	RESERVED FOR USE	NO
JP33	RESERVED FOR USE	NO
JP34	RESERVED FOR USE	NO
JP35	RESERVED FOR USE	NO
JP36	RESERVED FOR USE	NO
JP37	RESERVED FOR USE	NO
JP38	RESERVED FOR USE	NO
JP39	RESERVED FOR USE	NO
JP40	RESERVED FOR USE	NO
JP41	RESERVED FOR USE	NO
JP42	RESERVED FOR USE	NO
JP43	RESERVED FOR USE	NO
JP44	RESERVED FOR USE	NO
JP45	RESERVED FOR USE	NO
JP46	RESERVED FOR USE	NO
JP47	RESERVED FOR USE	NO
JP48	RESERVED FOR USE	NO
JP49	RESERVED FOR USE	NO
JP50	RESERVED FOR USE	NO
JP51	RESERVED FOR USE	NO
JP52	RESERVED FOR USE	NO
JP53	RESERVED FOR USE	NO
JP54	RESERVED FOR USE	NO
JP55	RESERVED FOR USE	NO
JP56	RESERVED FOR USE	NO
JP57	RESERVED FOR USE	NO
JP58	RESERVED FOR USE	NO
JP59	RESERVED FOR USE	NO
JP60	RESERVED FOR USE	NO
JP61	RESERVED FOR USE	NO
JP62	RESERVED FOR USE	NO
JP63	RESERVED FOR USE	NO
JP64	RESERVED FOR USE	NO
JP65	RESERVED FOR USE	NO
JP66	RESERVED FOR USE	NO
JP67	RESERVED FOR USE	NO
JP68	RESERVED FOR USE	NO
JP69	RESERVED FOR USE	NO
JP70	RESERVED FOR USE	NO
JP71	RESERVED FOR USE	NO
JP72	RESERVED FOR USE	NO
JP73	RESERVED FOR USE	NO
JP74	RESERVED FOR USE	NO
JP75	RESERVED FOR USE	NO
JP76	RESERVED FOR USE	NO
JP77	RESERVED FOR USE	NO
JP78	RESERVED FOR USE	NO
JP79	RESERVED FOR USE	NO
JP80	RESERVED FOR USE	NO
JP81	RESERVED FOR USE	NO
JP82	RESERVED FOR USE	NO
JP83	RESERVED FOR USE	NO
JP84	RESERVED FOR USE	NO
JP85	RESERVED FOR USE	NO
JP86	RESERVED FOR USE	NO
JP87	RESERVED FOR USE	NO
JP88	RESERVED FOR USE	NO
JP89	RESERVED FOR USE	NO
JP90	RESERVED FOR USE	NO
JP91	RESERVED FOR USE	NO
JP92	RESERVED FOR USE	NO
JP93	RESERVED FOR USE	NO
JP94	RESERVED FOR USE	NO
JP95	RESERVED FOR USE	NO
JP96	RESERVED FOR USE	NO
JP97	RESERVED FOR USE	NO
JP98	RESERVED FOR USE	NO
JP99	RESERVED FOR USE	NO
JP100	RESERVED FOR USE	NO
JP101	RESERVED FOR USE	NO
JP102	RESERVED FOR USE	NO
JP103	RESERVED FOR USE	NO
JP104	RESERVED FOR USE	NO
JP105	RESERVED FOR USE	NO
JP106	RESERVED FOR USE	NO
JP107	RESERVED FOR USE	NO
JP108	RESERVED FOR USE	NO
JP109	RESERVED FOR USE	NO
JP110	RESERVED FOR USE	NO
JP111	RESERVED FOR USE	NO
JP112	RESERVED FOR USE	NO
JP113	RESERVED FOR USE	NO
JP114	RESERVED FOR USE	NO
JP115	RESERVED FOR USE	NO
JP116	RESERVED FOR USE	NO
JP117	RESERVED FOR USE	NO
JP118	RESERVED FOR USE	NO
JP119	RESERVED FOR USE	NO
JP120	RESERVED FOR USE	NO
JP121	RESERVED FOR USE	NO
JP122	RESERVED FOR USE	NO
JP123	RESERVED FOR USE	NO
JP124	RESERVED FOR USE	NO
JP125	RESERVED FOR USE	NO
JP126	RESERVED FOR USE	NO
JP127	RESERVED FOR USE	NO
JP128	RESERVED FOR USE	NO
JP129	RESERVED FOR USE	NO
JP130	RESERVED FOR USE	NO
JP131	RESERVED FOR USE	NO
JP132	RESERVED FOR USE	NO
JP133	RESERVED FOR USE	NO
JP134	RESERVED FOR USE	NO
JP135	RESERVED FOR USE	NO
JP136	RESERVED FOR USE	NO
JP137	RESERVED FOR USE	NO
JP138	RESERVED FOR USE	NO
JP139	RESERVED FOR USE	NO
JP140	RESERVED FOR USE	NO
JP141	RESERVED FOR USE	NO
JP142	RESERVED FOR USE	NO
JP143	RESERVED FOR USE	NO
JP144	RESERVED FOR USE	NO
JP145	RESERVED FOR USE	NO
JP146	RESERVED FOR USE	NO
JP147	RESERVED FOR USE	NO
JP148	RESERVED FOR USE	NO
JP149	RESERVED FOR USE	NO
JP150	RESERVED FOR USE	NO
JP151	RESERVED FOR USE	NO
JP152	RESERVED FOR USE	NO
JP153	RESERVED FOR USE	NO
JP154	RESERVED FOR USE	NO
JP155	RESERVED FOR USE	NO
JP156	RESERVED FOR USE	NO
JP157	RESERVED FOR USE	NO
JP158	RESERVED FOR USE	NO
JP159	RESERVED FOR USE	NO
JP160	RESERVED FOR USE	NO
JP161	RESERVED FOR USE	NO
JP162	RESERVED FOR USE	NO
JP163	RESERVED FOR USE	NO
JP164	RESERVED FOR USE	NO
JP165	RESERVED FOR USE	NO
JP166	RESERVED FOR USE	NO
JP167	RESERVED FOR USE	NO
JP168	RESERVED FOR USE	NO
JP169	RESERVED FOR USE	NO
JP170	RESERVED FOR USE	NO
JP171	RESERVED FOR USE	NO
JP172	RESERVED FOR USE	NO
JP173	RESERVED FOR USE	NO
JP174	RESERVED FOR USE	NO
JP175	RESERVED FOR USE	NO
JP176	RESERVED FOR USE	NO
JP177	RESERVED FOR USE	NO
JP178	RESERVED FOR USE	NO
JP179	RESERVED FOR USE	NO
JP180	RESERVED FOR USE	NO
JP181	RESERVED FOR USE	NO
JP182	RESERVED FOR USE	NO
JP183	RESERVED FOR USE	NO
JP184	RESERVED FOR USE	NO
JP185	RESERVED FOR USE	NO
JP186	RESERVED FOR USE	NO
JP187	RESERVED FOR USE	NO
JP188	RESERVED FOR USE	NO
JP189	RESERVED FOR USE	NO
JP190	RESERVED FOR USE	NO
JP191	RESERVED FOR USE	NO
JP192	RESERVED FOR USE	NO
JP193	RESERVED FOR USE	NO
JP194	RESERVED FOR USE	NO
JP195	RESERVED FOR USE	NO
JP196	RESERVED FOR USE	NO
JP197	RESERVED FOR USE	NO
JP198	RESERVED FOR USE	NO
JP199	RESERVED FOR USE	NO
JP200	RESERVED FOR USE	NO

NOTE:  
1. SWITCHES, ELECTRICITY, AND COMPONENTS  
SHOWN IN THIS WIRING DIAGRAM ARE  
EQUIVALENTS TO THE EQUIPMENT  
HANDLING SOLID STATE COMPONENTS.  
2. RED WIRE ON CARBON CABLES MUST BE  
CONNECTED TO PIN 1 AT EACH END.

© 2014 Taylor Company

Figure 6-7 Diagram 059899-40 (C713)

Model C713  
059899-40  
09/14

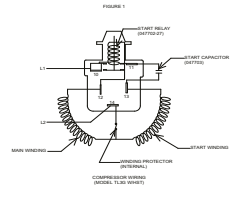
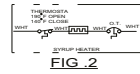
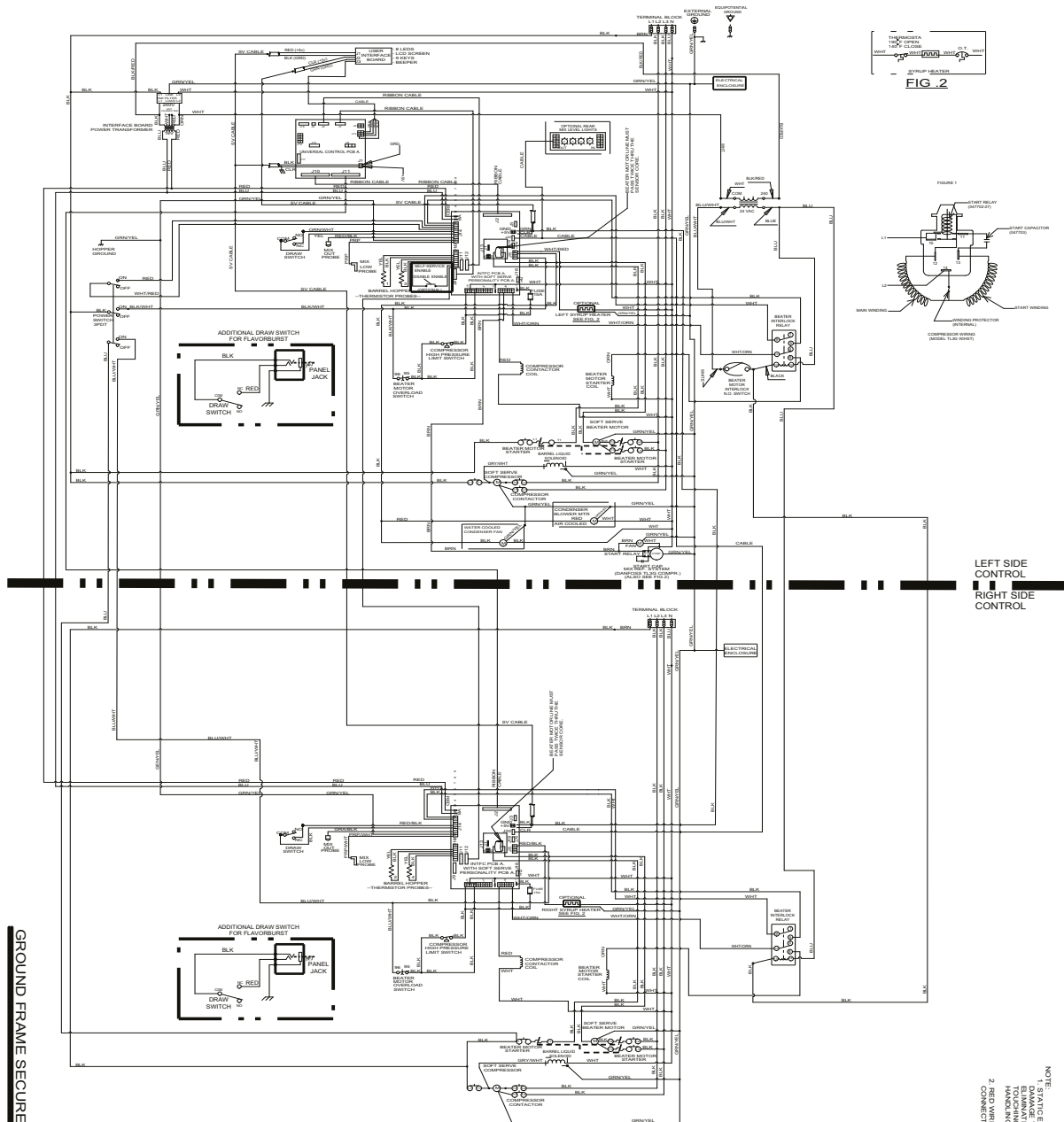

GROUND FRAME SECURELY

NOTE: 1. TAP TO ELECTRICAL WIRE CAUSE DAMAGE TO SOLID STATE COMPONENTS. TOUCHING OR SHORTING WIRE OR ONE HANDLING SOLID STATE COMPONENTS. 2. RED WIRE ON BROWN CABLES MUST BE CONNECTED TO PWR 1 AT EACH END.

UPCI BOARD	FUNCTION	INSTALLED INITIALLY
P1	TEMPERATURE SENSITIVE THERMISTOR (T1) IS CONNECTED TO A SOURCE OF POWER. A SHORT CIRCUIT OR OPEN CIRCUIT OF THE THERMISTOR WIRE WILL MAKE THE RELAY OPERATE. THIS RELAY IS INSTALLED TO PROTECT THE RELAY FROM OVERHEATING. YES	NO
P2	RESERVED FOR USE	NO
P3	RESERVED FOR USE	NO
P4	RESERVED FOR USE	NO
P5	RESERVED FOR USE	NO
P6	RESERVED FOR USE	NO
P7	RESERVED FOR USE	NO
P8	RESERVED FOR USE	NO
P9	RESERVED FOR USE	NO
P10	RESERVED FOR USE	NO
P11	RESERVED FOR USE	NO
P12	RESERVED FOR USE	NO
P13	RESERVED FOR USE	NO
P14	RESERVED FOR USE	NO
P15	RESERVED FOR USE	NO
P16	RESERVED FOR USE	NO
P17	RESERVED FOR USE	NO
P18	RESERVED FOR USE	NO
P19	RESERVED FOR USE	NO
P20	RESERVED FOR USE	NO
P21	RESERVED FOR USE	NO
P22	RESERVED FOR USE	NO
P23	RESERVED FOR USE	NO
P24	RESERVED FOR USE	NO
P25	RESERVED FOR USE	NO
P26	RESERVED FOR USE	NO
P27	RESERVED FOR USE	NO
P28	RESERVED FOR USE	NO
P29	RESERVED FOR USE	NO
P30	RESERVED FOR USE	NO
P31	RESERVED FOR USE	NO
P32	RESERVED FOR USE	NO
P33	RESERVED FOR USE	NO
P34	RESERVED FOR USE	NO
P35	RESERVED FOR USE	NO
P36	RESERVED FOR USE	NO
P37	RESERVED FOR USE	NO
P38	RESERVED FOR USE	NO
P39	RESERVED FOR USE	NO
P40	RESERVED FOR USE	NO
P41	RESERVED FOR USE	NO
P42	RESERVED FOR USE	NO
P43	RESERVED FOR USE	NO
P44	RESERVED FOR USE	NO
P45	RESERVED FOR USE	NO
P46	RESERVED FOR USE	NO
P47	RESERVED FOR USE	NO
P48	RESERVED FOR USE	NO
P49	RESERVED FOR USE	NO
P50	RESERVED FOR USE	NO
P51	RESERVED FOR USE	NO
P52	RESERVED FOR USE	NO
P53	RESERVED FOR USE	NO
P54	RESERVED FOR USE	NO
P55	RESERVED FOR USE	NO
P56	RESERVED FOR USE	NO
P57	RESERVED FOR USE	NO
P58	RESERVED FOR USE	NO
P59	RESERVED FOR USE	NO
P60	RESERVED FOR USE	NO
P61	RESERVED FOR USE	NO
P62	RESERVED FOR USE	NO
P63	RESERVED FOR USE	NO
P64	RESERVED FOR USE	NO
P65	RESERVED FOR USE	NO
P66	RESERVED FOR USE	NO
P67	RESERVED FOR USE	NO
P68	RESERVED FOR USE	NO
P69	RESERVED FOR USE	NO
P70	RESERVED FOR USE	NO
P71	RESERVED FOR USE	NO
P72	RESERVED FOR USE	NO
P73	RESERVED FOR USE	NO
P74	RESERVED FOR USE	NO
P75	RESERVED FOR USE	NO
P76	RESERVED FOR USE	NO
P77	RESERVED FOR USE	NO
P78	RESERVED FOR USE	NO
P79	RESERVED FOR USE	NO
P80	RESERVED FOR USE	NO
P81	RESERVED FOR USE	NO
P82	RESERVED FOR USE	NO
P83	RESERVED FOR USE	NO
P84	RESERVED FOR USE	NO
P85	RESERVED FOR USE	NO
P86	RESERVED FOR USE	NO
P87	RESERVED FOR USE	NO
P88	RESERVED FOR USE	NO
P89	RESERVED FOR USE	NO
P90	RESERVED FOR USE	NO
P91	RESERVED FOR USE	NO
P92	RESERVED FOR USE	NO
P93	RESERVED FOR USE	NO
P94	RESERVED FOR USE	NO
P95	RESERVED FOR USE	NO
P96	RESERVED FOR USE	NO
P97	RESERVED FOR USE	NO
P98	RESERVED FOR USE	NO
P99	RESERVED FOR USE	NO
P100	RESERVED FOR USE	NO

© 2014 Taylor Company

Figure 6-8 Diagram 059899-58 (C713)

Model C713  
059899-58  
09/14

